

Yesleen Gupta

COORDINATION CHEMISTRY

AJAI KUMAR
Assistant Professor
Department of Chemistry
Hindu College, University of Delhi
Delhi

2014

AARYUSH EDUCATIONS
B-3/2, Ground Floor, DLF, Ankur Vihar
Ghaziabad (U.P.)

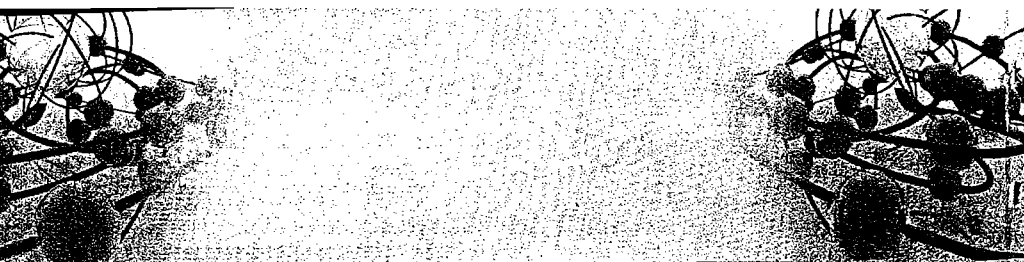

Published by:

AARYUSH EDUCATIONS

B-3/2, Ground Floor, DLF, Ankur Vihar
 Ghaziabad (U.P.)
 Mob. No.-09650813715
 09312466953
 09457640709

© Author

Second Edition : 2014

Design by :
 Prakash Graphics

PRICE : ₹ 350

No part of this book may be reproduced in a retrieval system or transmitted, in any form or by any means electronics, mechanical photo-copying, recording and / or without permission of the Author/publishers.

- ① elemental state of atoms don't behave as ligands
- ② when metal is large sized then ligands act as bidentate otherwise Mono.

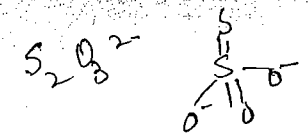

- ③ CO, CH₃, C₂H₅, H } bridging, form 3c-2e bond
- ④ Porphyrin is neutral in nature

To my 'PARENTS'

- ⑤ NH₂-NH₂, CN⁻ → Not ambidentate
- ⑥ Exception [Cr(N)₆]⁴⁺ → Cr²⁺ —Ajai Kumar
 d²sp³ But $\mu \neq 0$ since all are not paired
 due to repulsion (2 unpaired)

- ⑦ CN⁻ → π is formed by Cu(I), Ag(I), Au(I), & Hg²⁺
- ⑧ Exception ① K₂[NiF₆] → low spin (Diamagnetic)
- ② [Co(NH₃)₄]²⁺ → high spin t_{2g}⁵ e_g²

⑨ Normal Spinel | Inverse Spinel

O ²⁻ Lpt		O ²⁻ Lpt
A ²⁺		A ²⁺ → 1/4 oct.
1/8 th Tet		B ³⁺ 1/4 oct + 1/8 Tet
B ³⁺ 1/2 th Oct		

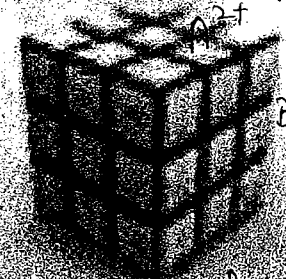

	Lpt	Oct	Tet
Normal	4	4	8
	4	2	1
Inverse	4	B ³⁺ 1	A ²⁺ 1

Foreword

I feel pleasure to introduce this book. The content given in the book will be invaluable to teaching and learning concept of coordination chemistry. I also feel pleasure that this book is written by my colleague. We (myself, Ajai Kumar and Meenu Srivastava) normally share and discuss the fundamentals of inorganic chemistry including coordination chemistry when we are in laboratory, staff room or the teacher's room.

The question, fill in the blanks, objective and subjective have the levels of various competition exams like IIT-JAM, CSIR-UGC (JRF/NET), GATE, IISc, BARC, TIFR, DRDO, ONGC, NTPC, NBRC etc. The fundamentals of coordination chemistry are written according to the need of the students. I wish that this book may give a way of sure success.

Dr. Ram Sharan
Associate Professor
Deptt. of Chemistry
Hindu College,
University of Delhi
Delhi

Preface

In this book I have attempted to highlight the concepts of Coordination Compounds relevant to students of undergraduate and postgraduate levels of all Indian universities. I have written this book in a readable and easily understandable way. Numerous examples are provided throughout the text.

In the text, I have incorporated the changes to the rules made for the nomenclature of coordination compounds by the IUPAC in the latest revision of 2005. I have given the detail description of isomerism (mainly *facial-meridional*), nomenclature (mainly complexes containing cation and anion both as complex ions), bonding theories, magnetic properties, colour and electronic spectra, stability and reaction mechanism. I felt that the students face the various problems regarding the fundamentals of coordination chemistry. Therefore, I had decided to write the book on fundamentals of coordination chemistry.

I hope that this book will be very helpful for the aspirants of all competitive exams related to chemistry like IIT-JAM, CSIR-UGC (NET/JRF), GATE, TIFR, BARC, IISc, DRDO, ONGC, NTPC etc.

I have incorporated large number of objective questions asked in the past competitive exams to know the level of question paper for future competitive examinations. The category "Fill in the blanks" are especially incorporated for the aspirants of IIT-JAM examination.

I have taken particular care to ensure that the text is free of errors.

I thank to Mr. Prakash Arora for designing and giving a good look to the book. I thank to Mr. Anil Goriyan whose efforts made the completion of this book.

I express my sincere thanks to my daughter—Little, my son—Aaryush and my wife—Mrs. Archana and my other family members.

I also thank to Dr. Meenu Srivastava, Dr. Sudarshan and Dr. Raghvi Khattar for their constructive suggestions.

If a learner found any error in the text, please send your constructive criticism and suggestions to update the book time to time. The criticism will be gratefully received and acknowledge.

—Ajai Kumar

15-Nov-2012

ajailcthc@rediffmail.com

P
R
E
F
A
C
E

Preface

2nd Edition

I feel pleasure to produce the fully revised second edition of the present book "coordination chemistry."

This becomes possible only by the valuable suggestions of students and teachers. In this edition some objective and subjective questions are added for the practice purpose of students. Some topics are elaborated and added like molecular orbital diagrams for tetrahedral and square planar complexes, synthesis of coordination compounds by electron transfer reactions, and photochemical reactions. I hope that this new edition will be very helpful for B.Sc. (H), M.Sc. and competitive exams like NET/JRF and IIT(JAM).

This edition is successfully produced with the help of Mr. Prakash Arora, Mr. Animesh Vashistha and Mr. Udhham Singh.

I also thank to Gulam Nabi for his valuable suggestions.

Once again thank to my family members for their cooperations.

If a learner found any error in the text, please send your constructive criticism and suggestions to update the book time to time. The criticism will be gratefully received and acknowledged.

—Ajai Kumar

15-Jan.-2014

ajailecthc@rediffmail.com

CONTENT

Coordination Chemistry

Chapter	Page No.
1. An Introduction to Coordination Compounds	1.1 – 1.24
2. Structure and Isomerism in Coordination Compounds	2.1 – 2.44
3. IUPAC Nomenclature of Coordination Compounds	3.1 – 3.18
4. Theories for Metal-Ligand Bonding in Complexes	4.1 – 4.60
5. Colour and Electronic Spectra	5.1 – 5.66
6. Magnetism	6.1 – 6.18
7. Stability of Complexes and Reaction Mechanism	7.1 – 7.80

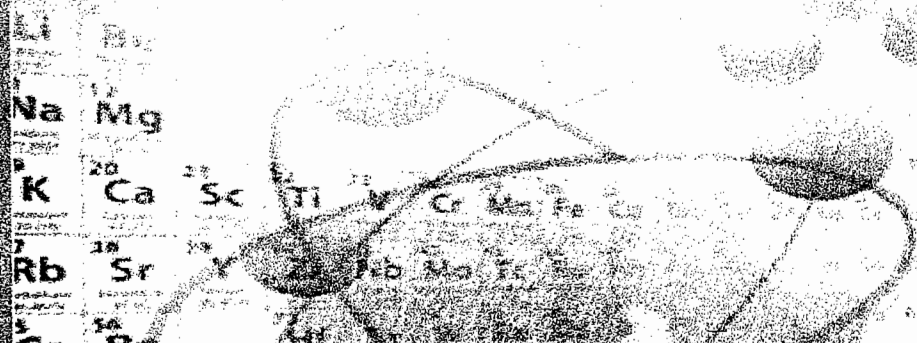

ALD / f b/w double salt &
Co-ordination compound

C-C → don't dissociate

Double salt - dissociates

Key

Ag	47	atomic No.
Pd	46	
Pt	78	

NO_2^- ambidentate
 NO_3^- Not ambidentate
 N^- don't behave as ambident

1

An Introduction to Coordination Compounds

Any species (ion or molecule) that have at least one lone pair of electrons and that can donate its lone pair of electrons to a metal cation or atom is called a ligand. Since a ligand is an electron rich species, therefore, it is also called a Lewis base or a nucleophile. A metal cation is an electron deficient species and it can accept a pair of electrons, therefore, a metal cation behaves as a Lewis acid or an electrophile. When a group of ligands donates its pairs of electrons (one pair by one donor atom of a ligand) to the metal cation or atom coordinate bonds are formed and the product so formed is called a coordination compound. Thus, a compound in which a metal cation or atom is attached to a group of ligands by coordinate bonds is called a coordination compound or complex compound. The coordination compounds may either be neutral molecules or ionic compounds. The compounds like $[\text{Pt}(\text{NH}_3)_2\text{Cl}_2]^{2+}$, $[\text{Co}(\text{NH}_3)_3\text{Cl}_3]^{3+}$ are neutral coordination compounds. In ionic coordination compounds either the cation or anion or both may be complex ions. For example, $[\text{Co}(\text{NH}_3)_6]\text{Cl}_3$ contains $[\text{Co}(\text{NH}_3)_6]^{3+}$ as complex cation, $\text{K}_4[\text{Fe}(\text{CN})_6]$ contains $[\text{Fe}(\text{CN})_6]^{4-}$ as complex anion and $[\text{Pt}(\text{NH}_3)_4][\text{PtCl}_4]$ contains $[\text{Pt}(\text{NH}_3)_4]^{2+}$ and $[\text{PtCl}_4]^{2-}$ as complex ions i.e., complex cation and complex anion respectively. The coordination compounds retain their identity, more or less even in solution, though partial dissociation may occur. These compounds do not give the tests of all their constituent ions in aqueous solution i.e., some constituent ions lost their individual identities in aqueous solution. For example, $[\text{Co}(\text{NH}_3)_6]\text{Cl}_3$ is a complex compound and it does not give the test of all the constituent ions, Co^{3+} and Cl^- instead it gives the Co^{3+} as $[\text{Co}(\text{NH}_3)_6]^{3+}$ complex ion and Cl^- ions.

A complex ion is an ion in which a metal cation is attached to ligands by coordinate bonds.

Coordination chemistry is the branch of inorganic chemistry which concerns the study of coordination compounds.

In the structural formula of a coordination compound, the central metal cation or atom and the ligands attached to it are written in a square bracket, $[\]$ which is called a coordination sphere. The cation or anion outside the coordination sphere is called the ionization sphere or counter ion.

The atom in a ligand that is directly attached to the metal cation or atom is called the donor atom and the number of donor atoms attached to metal cation or atom is called the coordination number. For example, coordination number of Ag^+ in $[\text{Ag}(\text{NH}_3)_2]^{2+}$ is 2, that of Cu^{2+} in $[\text{Cu}(\text{NH}_3)_4]^{2+}$ is 4 and that of Co^{3+} in $[\text{Co}(\text{NH}_3)_6]^{3+}$ is 6.

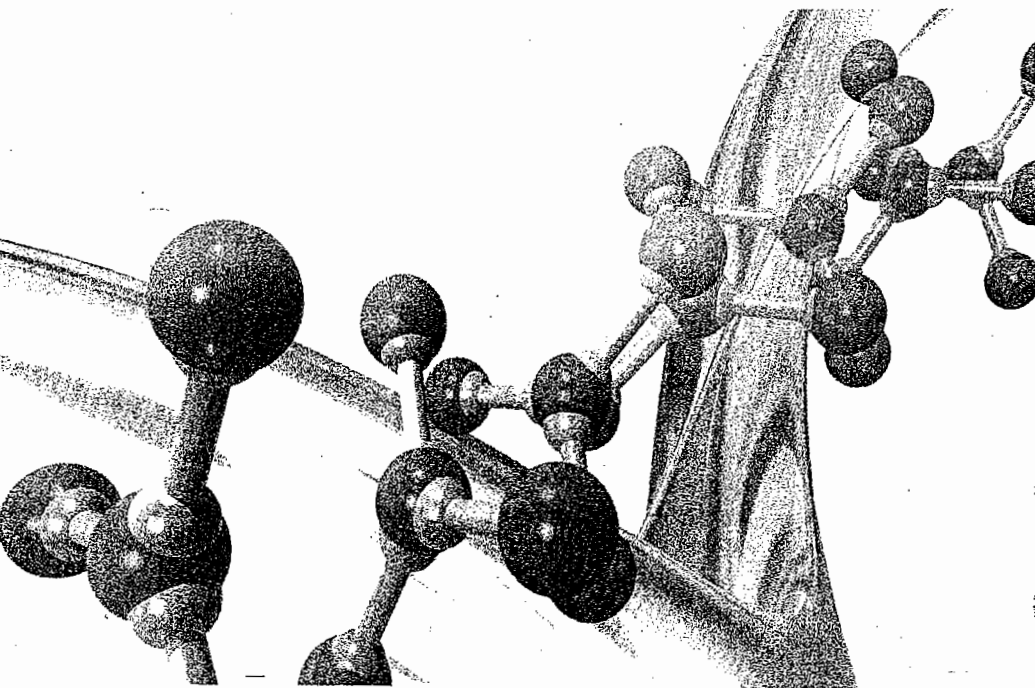

The terms discussed above are shown below:

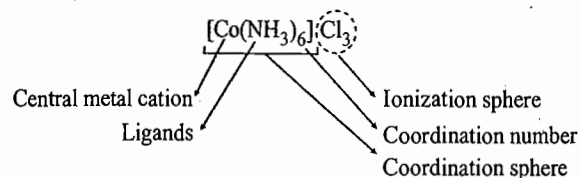

WERNER'S THEORY

In 1893 Werner produced a theory of coordination compounds to explain the structures and formation of compounds. Werner was the first inorganic chemist to be awarded the Noble prize for chemistry in 1913. Werner postulated that metals exhibit two types of valencies: (1) Primary valency and (2) secondary valency. In modern terminology, primary valency corresponds to the oxidation number and secondary valency to coordination number of metal.

The primary valency is ionizable and non-directional. The primary valency must be satisfied only by negative ions as in simple salts such as CoCl_3 .

Primary valency of cobalt in $[\text{Co}(\text{NH}_3)_6]\text{Cl}_3$, $[\text{Co}(\text{NH}_3)_5\text{Cl}]\text{Cl}_2$, $[\text{Co}(\text{NH}_3)_4\text{Cl}_2]\text{Cl}$ and $[\text{Co}(\text{NH}_3)_3\text{Cl}_3]$ complexes is +3 and is satisfied by three Cl^- ions. The anions which satisfy only primary valency are written outside the coordination sphere. The anions may satisfy primary as well as secondary valencies of metal. The anions which satisfy both primary and secondary valencies are placed inside the coordination sphere. The anions satisfying the primary valency do not give any geometry to the complex compound. When the compound undergoes ionization in aqueous solution, the anions which satisfy only primary valency are obtained. For example, when $\text{CoCl}_3 \cdot 6\text{NH}_3$ undergoes ionization in aqueous solution, three Cl^- ions which satisfy primary valency are obtained.

The secondary or auxiliary valencies of metal are satisfied either by negative ions or neutral molecules or both. In the structure of coordination compounds the metal cation and the species satisfying secondary valencies are placed inside the coordination sphere. The species satisfying secondary valencies are not obtained in aqueous solution in free state instead a complex ion is obtained. The secondary valencies are directed in space to give a definite geometry to the complex. The geometries of complexes corresponding to 2, 3, 4 and 6 secondary valencies are linear, trigonal planar, tetrahedral or square planar and octahedral respectively.

Werner studied the structure and properties of the following four complexes of Co(III) chloride with ammonia which have different colours.

Table 1.1 : Complexes of Co(III) Chloride with Ammonia

Compounds		Colour	Old Name	No. of Charges on Complex Ion	No. of Ions		
Old Formulae	New Formulae				Cation	Anion	Total
$\text{CoCl}_3 \cdot 6\text{NH}_3$	$[\text{Co}(\text{NH}_3)_6]\text{Cl}_3$	Yellow	Luteo complex	+3	1	3	4
$\text{CoCl}_3 \cdot 5\text{NH}_3$	$[\text{Co}(\text{NH}_3)_5\text{Cl}]\text{Cl}_2$	Purple	Purpureo complex	+2	1	2	3
$\text{CoCl}_3 \cdot 4\text{NH}_3$	<i>Trans</i> - $[\text{Co}(\text{NH}_3)_4\text{Cl}_2]\text{Cl}$	Green	Praseo complex	+1	1	1	2
$\text{CoCl}_3 \cdot 4\text{NH}_3$	<i>cis</i> - $[\text{Co}(\text{NH}_3)_4\text{Cl}_2]\text{Cl}$	Violet	Violeo complex	+1	1	1	2
$\text{CoCl}_3 \cdot 3\text{NH}_3$	$[\text{Co}(\text{NH}_3)_3\text{Cl}_3]$	Blue green	—	—	—	—	—

Werner treated the first four complexes of Co(III) given in Table 1.1 with an excess of AgNO_3 . The white precipitate of AgCl were obtained in different amount.

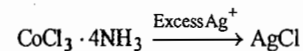
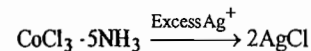
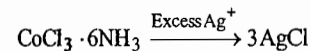

Werner reported that in $\text{CoCl}_3 \cdot 6\text{NH}_3$ all the three chlorides satisfy only primary valency and the six ammonia molecules satisfy only the secondary valency. The primary valencies represented by dotted lines (...) and secondary valencies are represented by solid line (—). The structure of $\text{CoCl}_3 \cdot 6\text{NH}_3$ is shown in Figure 1.1(a). This compound in aqueous solution gives total number of four ions i.e., three Cl^- and one $[\text{Co}(\text{NH}_3)_6]^{3+}$ ions. Thus, in modern term this compound is written as $[\text{Co}(\text{NH}_3)_6]\text{Cl}_3$. When this compound is treated with an excess of AgNO_3 solution, all three Cl^- ions are precipitated as AgCl .

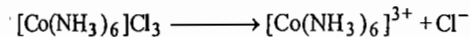

In $\text{CoCl}_3 \cdot 5\text{NH}_3$, the primary and the secondary valencies of cobalt are three and six respectively. All the three primary valencies are satisfied by three chloride ions. Out of six secondary valencies, five are satisfied by ammonia molecules and the sixth by one of the chloride ions. Therefore, one chloride ion

exhibits double duty as it satisfy a primary as well as a secondary valency and it is represented as =—= line. [Figure 1.1(b)]. When this compound is treated with an excess of AgNO_3 solution, only two chloride ions are precipitated as AgCl .

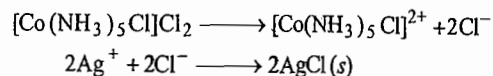

This indicates that the Cl^- ions which satisfy only the primary valencies are ionizable. In aqueous solution total number of three ions are obtained *i.e.*, one $[\text{Co}(\text{NH}_3)_5\text{Cl}]^{2+}$ and two Cl^- ions. In modern term this compound is written as $[\text{Co}(\text{NH}_3)_5\text{Cl}]\text{Cl}_2$. The structure of $[\text{Co}(\text{NH}_3)_5\text{Cl}]\text{Cl}_2$ is shown in Figure 1.1(b)

In $\text{CoCl}_3 \cdot 4\text{NH}_3$, the primary and secondary valencies of cobalt are 3 and 6 respectively. All the three primary valencies are satisfied by three chloride ions. Out of six secondary valencies, four are satisfied by ammonia molecules and fifth and sixth by two of the three chloride ions. Thus, two chloride ions exhibit double duty of satisfying primary as well as secondary valencies. When this compound is treated with an excess of AgNO_3 solution, only one chloride ion is precipitated as AgCl . In aqueous solution this compound gives total number of two ions *i.e.*, one $[\text{Co}(\text{NH}_3)_4\text{Cl}_2]^+$ and one Cl^- ion. This compound is written as $[\text{Co}(\text{NH}_3)_4\text{Cl}_2]\text{Cl}$. The structure of this compound is shown in Figure 1.1(c).

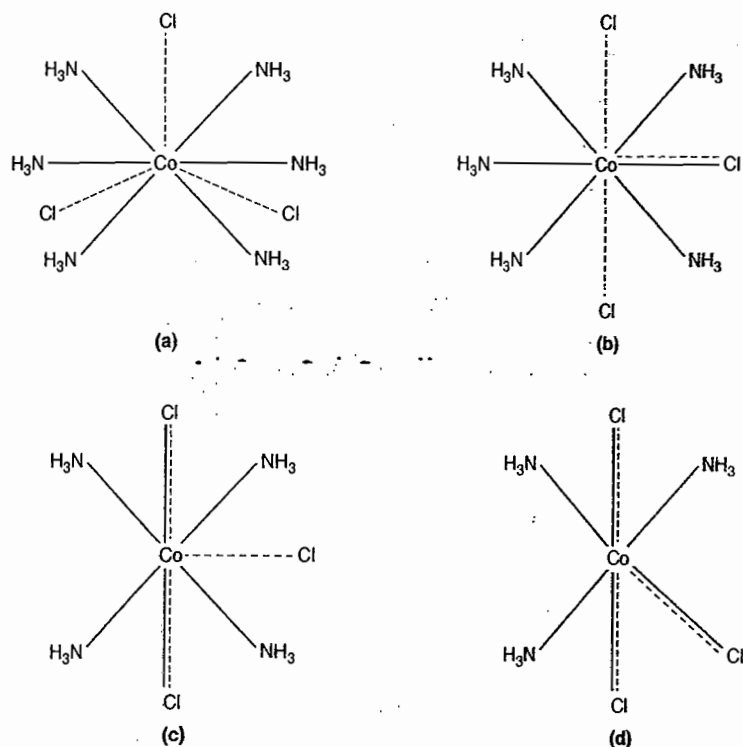
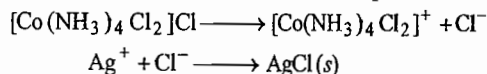

Figure 1.1

In $\text{CoCl}_3 \cdot 3\text{NH}_3$, primary and the secondary valencies of cobalt are three and six respectively. All the three primary valencies are satisfied by three chloride ions. Out of six secondary valencies, three are satisfied by three ammonia molecules and three by chloride ions. In this compound three chloride ions satisfy primary as well as secondary valencies. This compound does not give any precipitate with AgNO_3 solution. This compound is a neutral molecule and does not give any ion in aqueous solution. In modern term this compound is written as $[\text{Co}(\text{NH}_3)_3\text{Cl}_3]$. The structure of this compound is shown in Figure 1.1(d).

Werner also attempted to find the geometries of isomers of the complexes of Co(III) , Cr(III) , Cu(II) , Pt(II) etc. The various geometries for complexes of coordination no. 6 are hexagonal planar, trigonal prismatic and octahedral (Figure 1.2).

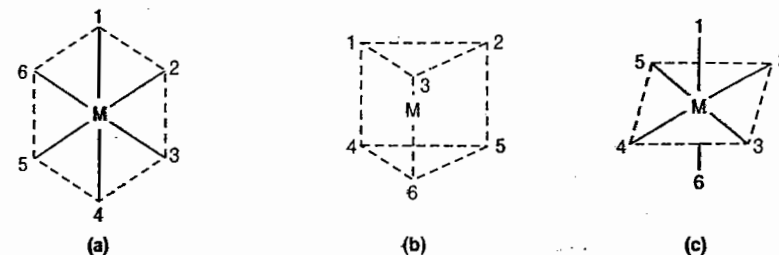

Figure 1.2 (a) Hexagonal (b) Trigonal prismatic (c) Octahedral

The possible isomers for the ammine complexes of Co(III) for all the three geometries are given in the table 1.2 :

Table 1.2 : Possible Isomers of Co(III) Complexes

Complexes	Theoretical			Observed
	Hexagonal Planar	Trigonal Prismatic	Octahedral	
$[\text{Co}(\text{NH}_3)_6]^{3+}$	1	1	1	1
$[\text{Co}(\text{NH}_3)_5\text{Cl}]^{2+}$	1	1	1	1
$[\text{Co}(\text{NH}_3)_4\text{Cl}_2]^+$	3	3	2	2
$[\text{Co}(\text{NH}_3)_3\text{Cl}_3]$	3	3	2	2

Consider the coordination compound $[\text{Co}(\text{NH}_3)_4\text{Cl}_2]\text{Cl}$. Werner suggested that this compound may exist in three possible geometries *i.e.*, hexagonal planar, trigonal prismatic and octahedral. The possible isomers corresponding to these geometries are three, three and two respectively as shown in Figure 1.3.

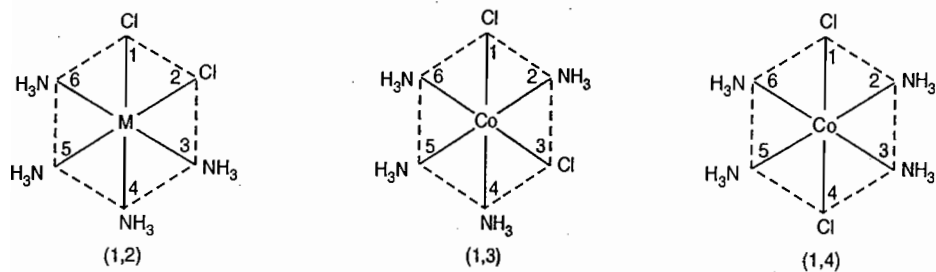

Figure 1.3 (a) Three possible isomers for hexagonal planar geometry.

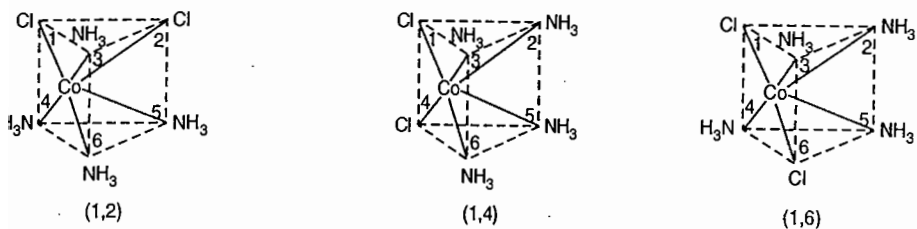

Figure 1.3 (b) Three possible isomers for trigonal prismatic geometry.

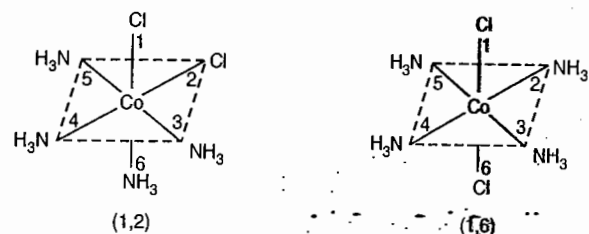

Figure 1.3 (c) Two possible for octahedral geometry.

Only two isomers of compound $[\text{Co}(\text{NH}_3)_4\text{Cl}_2]\text{Cl}$ has been isolated which correspond to the octahedral geometry. Thus, in these isomers the arrangement of ligands round the metal cation is octahedral. Werner concluded that the complexes of coordination number 6 are octahedral.

Werner also suggested that the coordination compounds with coordination number 4 exhibit two possible geometries *i.e.*, square planar and tetrahedral.

In coordination compound $[\text{Pt}(\text{NH}_3)_2\text{Cl}_2]$, coordination number is 4 and this compound exhibits square planar geometry. Two isomers *cis*- and *trans*- $[\text{Pt}(\text{NH}_3)_2\text{Cl}_2]$ has been isolated for this compound (Figure 1.4).

 Figure 1.4 *cis*- and *trans*- isomers of $[\text{Pt}(\text{NH}_3)_2\text{Cl}_2]$

Werner also suggested that in tetrahedral complexes only one arrangement is possible round the metal cation.

Evidence in Favour of Werner's Theory

(1) Electrical Conductance Measurement : Molar conductance of a substance depends upon the number of charges on the particles furnished by the substance in aqueous solution. As the number of particles (*i.e.*, ions) and charges on them increases, the molar conductance of the compound increases. The observed molar conductance for aqueous solutions of cobalt(III) chloride complexes with ammonia decreases in the order.

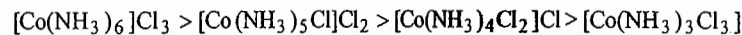

This indicates that the number of ions and the number of charges decrease in the same order as shown in the table 1.3 The molar conductance measurement of Co(III) chloride complexes with ammonia suggest the structures similar to structures suggested by Werner.

Table 1.3 : Elucidation of Structure of Co(III) and Pt(IV) Complexes on the Basis of Conductance and Cryoscopic Measurements.

Compound	Number of Particles Determined from Cryoscopic Measurement	Number of Electrical Charges Determined from Conductance Measurements	Structure of the Compound
$\text{CoCl}_3 \cdot 6\text{NH}_3$	4	$6(+3, -1)$	$[\text{Co}(\text{NH}_3)_6]^{3+} 3\text{Cl}^-$
$\text{CoCl}_3 \cdot 5\text{NH}_3$	3	$4(+2, -1)$	$[\text{Co}(\text{NH}_3)_5\text{Cl}]^{2+} 2\text{Cl}^-$
$\text{CoCl}_3 \cdot 4\text{NH}_3$	2	$2(+1, -1)$	$[\text{Co}(\text{NH}_3)_4\text{Cl}_2]^+ \text{Cl}^-$
$\text{CoCl}_3 \cdot 3\text{NH}_3$	0	0	$[\text{Co}(\text{NH}_3)_3\text{Cl}_3]$
$\text{PtCl}_4 \cdot 6\text{NH}_3$	5	$8(+4, -1)$	$[\text{Pt}(\text{NH}_3)_6]^{4+} 4\text{Cl}^-$
$\text{PtCl}_4 \cdot 5\text{NH}_3$	4	$6(+3, -1)$	$[\text{Pt}(\text{NH}_3)_5\text{Cl}]^{3+} 3\text{Cl}^-$
$\text{PtCl}_4 \cdot 4\text{NH}_3$	3	$4(+2, -1)$	$[\text{Pt}(\text{NH}_3)_4\text{Cl}_2]^{2+} 2\text{Cl}^-$
$\text{PtCl}_4 \cdot 3\text{NH}_3$	2	$2(+1, -1)$	$[\text{Pt}(\text{NH}_3)_3\text{Cl}_3]^+ \text{Cl}^-$
$\text{PtCl}_4 \cdot 2\text{NH}_3$	0	0	$[\text{Pt}(\text{NH}_3)_2\text{Cl}_4]^0$

(2) **Cryoscopic Measurement** : The depression in freezing point is a colligative property and depends upon the number of particles in the solution. Greater the number of particles, more will be the depression in freezing point. If a species dissociates into two, three, four, ... ions, then depression in freezing point will be twice, three times, four times, ... respectively as compared to the expected depression for single species. Thus, cryoscopic measurement (i.e., measurement of depression in freezing point) gives the number of ions furnished by the dissociation of an ionic compound. The cryoscopic measurement indicates that $\text{CoCl}_3 \cdot 6\text{NH}_3$, $\text{CoCl}_3 \cdot 5\text{NH}_3$ and $\text{CoCl}_3 \cdot 4\text{NH}_3$ dissociate to give 4, 3 and 2 ions respectively whereas $\text{CoCl}_3 \cdot 3\text{NH}_3$ remains undissociated (see table 1.3).

(3) **Precipitation Reactions** : The number of ions furnished by a coordination compound can also be determined by precipitation reactions. When the complexes $\text{CoCl}_3 \cdot 6\text{NH}_3$, $\text{CoCl}_3 \cdot 5\text{NH}_3$ and $\text{CoCl}_3 \cdot 4\text{NH}_3$ are treated with an excess of AgNO_3 solution, the number of chloride ions precipitated as AgCl is 3, 2 and 1 respectively. This indicates that the number of chloride ions in ionization sphere are 3, 2 and 1 respectively. The structures provided by precipitation reactions are similar to those given by Werner. The complex $\text{CoCl}_3 \cdot 3\text{NH}_3$ gives no precipitate with AgNO_3 solution. This indicates that all the three Cl^- ions are present in the coordination sphere in this compound.

Electronic spectra (UV- visible) and X-rays spectroscopy are the recent methods to determine the structure of complexes. Electronic spectra give the information about the energies of orbitals, shapes of complexes (i.e., either the complex is octahedral or distorted octahedral or tetrahedral). X-rays spectroscopy gives the information about the structure of complex, bond lengths and bond angles. Magnetic moment measurement gives the information about the complexes viz. either the complex is tetrahedral or square planar or octahedral.

Sidgwick Concept of Coordinate Bond

According to Sidgwick's concept the ligands donate electron pairs to the metal cation or atom resulting in the formation of the coordinate bonds between metal and the ligands which is represented as $\text{M} \leftarrow \text{L}$. Therefore, the complex ion, $[\text{Co}(\text{NH}_3)_6]^{3+}$ can be written as :

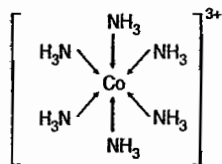

The donation of an electron pair by N atom of NH_3 has been represented by an arrow. The coordinate bond is very similar to covalent bond.

Limitations of Sidgwick's Concept : The donation of one electron pair by each ligand to the central metal cation atom to form $\text{M} \leftarrow \text{L}$ coordinate bonds cause the accumulation of negative charge on the central metal cation or atom. Due to accumulation of a negative charge on the metal cation or atom, a partial ionic character is created in the complex making it less stable.

According to Pauling's **electroneutrality principle**, the metal ligand bonds have some ionic character. To prevent the accumulation of negative charge on metal cation or atom, either the bond pair of electrons must be attracted more strongly to the donor atoms of the ligands or in addition to the σ -bond there should be metal to ligand π -bonding.

Effective Atomic Number (EAN) Rule : The effective atomic number of metal cation or atom in a complex is the sum of electrons on metal and the electrons donated by the ligands. According to Sidgwick's effective atomic number (EAN) rule, the EAN of metal is equal to the atomic number of next

inert gas i.e., equal to 36 (Kr), 54 (Xe) or 86 (Rn). For example, EAN of $[\text{Co}(\text{NH}_3)_6]^{3+}$ can be calculated as follows :

$$\text{Number of electrons on Co atom} = 27$$

$$\text{Number of electrons on Co}^{3+} \text{ ion} = 27 - 3 = 24$$

$$\text{Number of electrons donated by six NH}_3 \text{ ligands} = 2 \times 6 = 12$$

$$\text{EAN of Co}^{3+} \text{ in } [\text{Co}(\text{NH}_3)_6]^{3+} = 24 + 12 = 36$$

An alternate and more general rule is the **18 electron rule**. According to this rule, in a complex the sum of valence electrons and the electrons donated by the ligands is 18. It provides a closed and stable configuration, $ns^2 (n-1)d^{10} np^6$.

For example : For $[\text{Co}(\text{NH}_3)_6]^{3+}$

$$\text{Valence shell electronic configuration of } {}_{27}\text{Co} = 3d^7 4s^2$$

$$\text{Valence shell electronic configuration of Co}^{3+} = 3d^6 4s^0$$

$$\text{Number of electrons in valence shell of Co}^{3+} = 6$$

$$\text{Number of electron donated by six NH}_3 \text{ molecules} = 2 \times 6 = 12$$

$$\text{Number of valence electrons in } [\text{Co}(\text{NH}_3)_6]^{3+} = 6 + 12 = 18 e^-$$

The complexes which follow the EAN or 18 electron rule are considered to be stable. EAN and 18 electron rules are similar but the 18 electron rule is more advantageous because there is no need to remember the atomic numbers of each noble gas. However, there are some exceptions which obey neither EAN nor 18 electron rule. The complexes in which the metal cations or atoms have odd number of electrons never obey the EAN rule or 18 electron rule because the sum of total electrons or valence shell electrons and the electrons donated by the ligands is also an odd number. For example, consider the complex $[\text{Fe}(\text{CN})_6]^{3-}$.

For EAN Rule :

$$\text{Number of electrons on Fe atom} = 26$$

$$\text{Number of electron on Fe}^{3+} \text{ ion} = 23$$

$$\text{Number of electrons donated by six CN}^- \text{ ligands} = 2 \times 6 = 12$$

$$\text{EAN of } [\text{Fe}(\text{CN})_6]^{3-} = 23 + 12 = 35$$

Thus, $[\text{Fe}(\text{CN})_6]^{3-}$ does not obey EAN rule.

For 18 Electron Rule :

$$\text{Valence shell electronic configuration of Fe atom} = 3d^6 4s^2$$

$$\text{Valence shell electronic configuration of Fe}^{3+} \text{ ion} = 3d^5$$

$$\text{Number of valence electron in Fe}^{3+} \text{ ion} = 5$$

$$\text{Number of electron donated by six CN}^- \text{ ligands} = 2 \times 6 = 12$$

$$\text{Number of valence electrons in } [\text{Fe}(\text{CN})_6]^{3-} = 5 + 12 = 17$$

Thus, $[\text{Fe}(\text{CN})_6]^{3-}$ does not obey the 18 electron rule.

The complexes of d^8 metals having coordination number 4 also obey neither EAN rule nor 18 electron rule. For example, the complexes $[\text{NiCl}_4]^{2-}$, $[\text{Ni}(\text{CN})_4]^{2-}$, $[\text{PdCl}_4]^{2-}$, $[\text{PtCl}_4]^{2-}$ obey neither the EAN rule nor 18 electron rule.

The illustration of EAN and 18 electron rule is given in Table 1.4.

Table 1.4 : Illustration of EAN and 18 Electron Rule for Various Complexes

Complex Ion	EAN Rule				EAN	18 Electron Rule	
	Atomic Number of the Metal	Oxidation State of the Metal	No. of Electrons on Metal Cation/Atom	No. of Electrons Donated by the Ligands		Valence Shell Electrons of the Metal Cation	Total Valence Electrons of the Complex Ion
$[\text{Co}(\text{NH}_3)_6]^{3+}$	27	+3	24	$2 \times 6 = 12$	$24 + 12 = 36$ (Kr)	6	$6 + 12 = 18$
$[\text{Fe}(\text{CN})_6]^{4-}$	26	+2	24	$2 \times 6 = 12$	$24 + 12 = 36$ (Kr)	6	$6 + 12 = 18$
$[\text{PtCl}_6]^{2-}$	78	+4	74	$2 \times 6 = 12$	$74 + 12 = 86$ (Rn)	6	$6 + 12 = 18$
$[\text{Cu}(\text{CN})_4]^{3-}$	29	+1	28	$2 \times 4 = 8$	$28 + 8 = 36$ (Kr)	10	$10 + 8 = 18$
$\text{Fe}(\text{CO})_5$	26	0	26	$2 \times 5 = 10$	$26 + 10 = 36$ (Kr)	8	$8 + 10 = 18$
$\text{Cr}(\text{CO})_6$	24	0	24	$2 \times 6 = 12$	$24 + 12 = 36$ (Kr)	6	$6 + 12 = 18$
$\text{Ni}(\text{CO})_4$	28	0	28	$2 \times 4 = 8$	$28 + 8 = 36$ (Kr)	10	$10 + 8 = 18$
* $[\text{Cr}(\text{CN})_6]^{3-}$	24	+3	21	$2 \times 6 = 12$	$21 + 12 = 33$	3	$3 + 12 = 15$
* $[\text{FeCl}_4]^{2-}$	26	+2	24	$2 \times 4 = 8$	$24 + 8 = 32$	6	$6 + 8 = 14$
* $[\text{NiCl}_4]^{2-}$	28	+2	26	$2 \times 4 = 8$	$26 + 8 = 34$	8	$8 + 8 = 16$
* $[\text{Ni}(\text{CN})_4]^{2-}$	28	+2	26	$2 \times 4 = 8$	$26 + 8 = 34$	8	$8 + 8 = 16$
* $[\text{PdCl}_4]^{2-}$	46	+2	44	$2 \times 4 = 8$	$44 + 8 = 52$	8	$8 + 8 = 16$
* $[\text{PtCl}_4]^{2-}$	78	+2	76	$2 \times 4 = 8$	$76 + 8 = 84$	8	$8 + 8 = 16$
* $[\text{Ag}(\text{NH}_3)_2]^+$	47	+1	46	$2 \times 2 = 4$	$46 + 4 = 50$	10	$10 + 4 = 14$

* These complexes obey neither EAN rule nor 18 electron rule.

CLASSIFICATION OF LIGANDS

Ligands can be classified as monodentate or polydentate ligands (viz., bidentate, tridentate, ...), depending on the number of ligand donor atoms that attach to the metal ion or atom.

(1) Monodentate Ligands : A ligand which shares electron pair of a single donor atom with a metal atom or ion is called a monodentate ligand. The word monodentate comes from the Greek : monos and the Latin : dentis, monos means one and dentis means tooth, literally means one tooth. Therefore, it means that a monodentate ligand bites a metal cation or atom with one lone pair of electrons. In general, the denticity of a ligand is the number of pairs of electrons shared with the metal atom or ion. Some common monodentate ligands are shown below :

Negative ligands

F^- fluoro	Cl^- chloro	Br^- bromo
I^- iodo	OH^- hydroxo	O^{2-} oxo
O_2^{2-} peroxo	O_2^- superoxo	H^- hydrido
CH_3COO^- acetato	CO_3^{2-} carbonato	SO_3^{2-} sulphito
SO_4^{2-} sulphato	S^{2-} sulphido	NH_2^- amido
NH^- imido	N^{3-} nitrido	N_3^- azido
$\text{S}_2\text{O}_3^{2-}$ thiosulphato	CN^- cyano	NO_3^- nitrato
$-\text{NO}_2^-$ nitro (or nitrito - N)	$-\text{ONO}$ nitrito (or nitrito - O)	
$-\text{SCN}^-$ thiocyanato (or thiocyanato - S)		
$-\text{NCS}^-$ isothiocyanato (or thiocyanato - N)		
$-\text{CNO}^-$ Cyanato		
$-\text{ClO}_3^-$ chlorato		

Neutral ligands which are named as such :

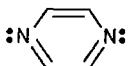
$(\text{C}_6\text{H}_5)_3\text{P}$	triphenyl phosphine	$(\text{C}_2\text{H}_5)_3\text{P}$	triethyl phosphine
C_2H_4	ethylene	$\text{C}_5\text{H}_5\text{N}$	pyridine (py)
$\text{NH}_2 - \text{NH}_2$	hydrazine	CH_3NH_2	methylamine
$(\text{CH}_3)_2\text{NH}$	dimethylamine	$(\text{CH}_3)_3\text{N}$	trimethylamine
$(\text{C}_6\text{H}_5)_3\text{As}$	triphenylarsine	CH_3CN	methyl cyanide or acetonitrile
CH_3NC	methylisocyanide	CH_3OCH_3	dimethyl ether
$\text{C}_2\text{H}_5\text{OC}_2\text{H}_5$	diethyl ether		pyrazine
NH_2OH	hydroxylamine	O_2	dioxygen
N_2	dinitrogen		

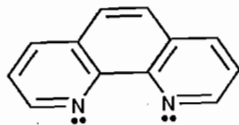

1, 10 - phenanthroline
or *o*-phenanthroline (*o*-phen or phen)

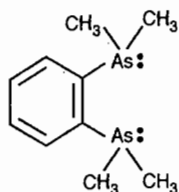

o-phenylene bisdimethylarsine (diars)

Note : The ligands like CO_3^{2-} , CH_3COO^- , NO_2^- , NO_3^- , SO_3^{2-} , SO_4^{2-} , $\text{NH}_2 - \text{NH}_2$, O_2 , N_2 etc have two donor atoms but in general, they act as monodentate ligands. They form either four or three membered rings including metal cation or atom and there will be repulsion between donor atoms which causes the ring to be strained and hence unstable.

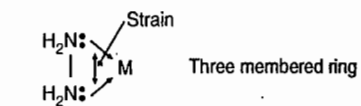
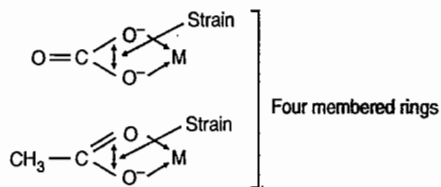

These ligands may behave as bidentate ligands when the size of metal cation is large like lanthanoids. For example, NO_3^- behaves as bidentate ligand in $[\text{Ce}(\text{NO}_3)_6]^{2-}$ in which coordination number of Ce^{4+} is 12.

(2) Tridentate Ligands

Some important examples of tridentate ligands are shown below :

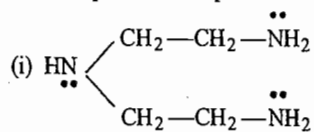

diethylenetriamine (dien)

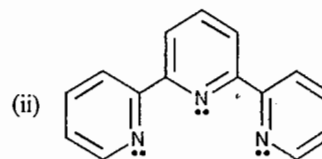

2,2',2''-terpyridine or terpyridyl (terpy)

(3) Tetradentate Ligands

Some important examples of tetradentate ligands are given below :

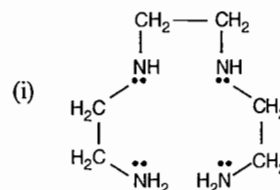

triethylenetetraamine (trien)

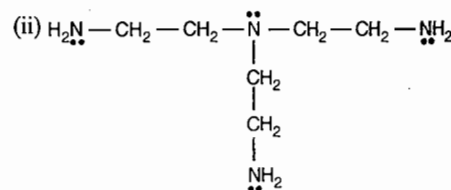

triaminotriethylamine (tren)

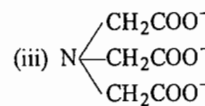

Nitrilotriacetate (NTA)

(4) Pentadentate Ligands

Important examples of pentadentate ligands are given below :

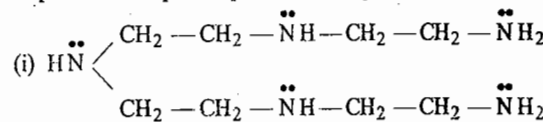

tetraethylenepentaamine (tetraen)

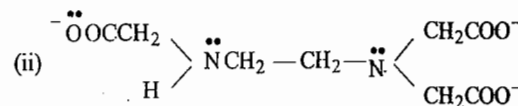

ethylenediaminetriacetate

(5) Hexadentate Ligands

The most important example of hexadentate ligands is :

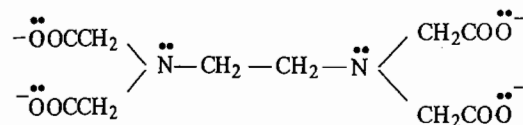

ethylenediaminetetraacetate (edta or EDTA)

Since EDTA⁴⁻ bonds to a metal ion through six donor atoms, therefore, it forms highly stable complexes and in general, is used to hold metal ions in solution.

EDTA⁴⁻ ligand is used to trap metal ions such as Mg⁺ and Ca²⁺ ions in hard water.

EDTA⁴⁻ is also used to treat metal, specially lead poisoning. Six donor atoms of EDTA⁴⁻ bond to Pb²⁺ ion to form very stable complex ion (Figure 1.5) which is removed from the blood and tissues and excreted from the body with the help of kidneys as soluble chelate, [Pb(EDTA)]²⁻.

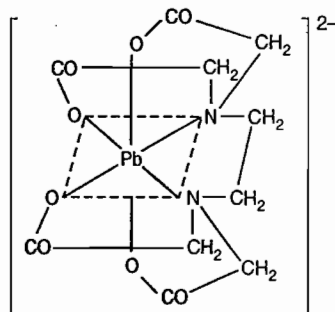

Figure 1.5: EDTA⁴⁻ complex of Pb²⁺

AMBIDENTATE LIGANDS

The monodentate ligands which have two or more different donor atoms can coordinate to a metal cation through either of the two different atoms. These ligands are called ambidentate ligands. When an ambidentate ligand coordinates to the metal cation through either of the two donor atom, two different compounds are obtained which are called linkage isomers. Examples of ambidentate ligands are :

---SCN⁻, ---NO₂⁻, ---S₂O₃²⁻, CO, CN⁻, SO₃²⁻, (NH₂)₂CO, (NH₂)₂CS and (CH₃)₂SO. But except ---NO₂⁻, ---SCN⁻ and S₂O₃²⁻ none of these has yet produced linkage isomers. NO₂⁻ ligand, for example, can coordinate to a metal cation through either N or O atom as shown in Figure 1.6.

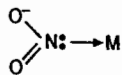

Figure 1.6(a): N-atom coordinated to metal.

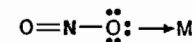
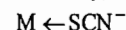

Figure 1.6(b): Oxygen atom coordinated to metal.

Similarly, SCN⁻ can coordinate with a metal cation either through S or N atom as shown below :



S - atom of SCN⁻

coordinated to metal ion



N - atom of SCN⁻

coordinated to metal ion

BRIDGING LIGANDS

The ligands in which one or two different donor atoms have atleast two pairs of electrons and share these electron pairs with two metal ions or atoms (one pair with one atom or ion) simultaneously are called bridging ligands. The interaction of bridging ligands with metal ions or atoms can be represented as M ← : L : → M.

The monodentate ligands having two lone pair of electrons on one donor atom which act as bridging ligands are H₂: $\ddot{\text{O}}$: $\ddot{\text{O}}$ H⁻, : $\ddot{\text{N}}$ H₂, F⁻, Cl⁻, Br⁻, I⁻, O²⁻ etc. The monodentate ligands having two lone pairs on two different atoms (one pair on one atom) are :SCN⁻: , :CO:, :CN⁻, $\ddot{\text{N}}$ H₂ --- $\ddot{\text{N}}$ H₂,

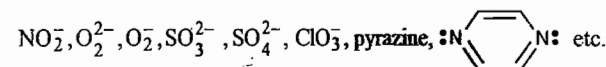

The bridging ligands in which each of the two different donor atoms has atleast two pairs of electrons like SCN⁻, either one or both donor atoms of the ligands, can coordinate to two different metal atoms or ions.

A bridging ligand forms two σ-bonds with two metal ions or atoms (one σ-bond with one metal ion or atom) and these complexes are called bridging complexes or multinuclear or polynuclear complexes.

If a bridging ligand contain two different donor atoms with one lone pair of electron on each, then one donor atom is coordinated to one metal and the other donor atom to the other metal.

For example :

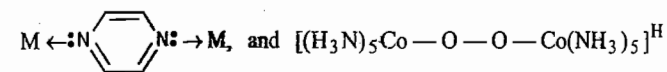

FLEXIDENTATE LIGANDS

There are several ligands which have two or more donor atoms. These ligands can coordinate with metal atom or ion either through one donor atoms forming non-chelated complex or two donor atoms forming a chelate. These ligands are called flexidentate ligands. Examples of such type of ligands are :

CO₃²⁻, SO₃²⁻, SO₄²⁻, NO₃⁻, N₂, O₂, $\ddot{\text{N}}$ H₂ --- $\ddot{\text{N}}$ H₂ etc. When these ligands behave as monodentate

Same done as above

ligands, the complexes so formed are really stable. But when these ligands behave as bidentate ligands, they form chelates containing three or four membered rings including metal ion or atom as shown below:

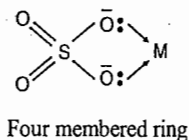
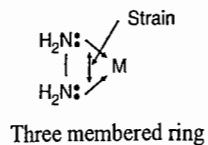

In general, the chelates having three or four membered rings are unstable because of the steric strain. However, exceptionally there are some stable chelates having four membered rings like $[\text{Ce}(\text{NO}_3)_6]^{2-}$, $[\text{Co}(\text{CO}_3)_3]^{3-}$ etc. EDTA⁴⁻ is a hexadentate ligand, but some times it acts as pentadentate or tetradentate ligand depending upon the size and stereochemistry of the chelate formed. For example, in complexes $[\text{Cr}(\text{OH})(\text{HEDTA})]^{2-}$ and $[\text{CoBr}(\text{HEDTA})]^{2-}$, EDTA acts as pentadentate ligand and in complex $[\text{Pd}(\text{H}_2\text{EDTA})]^{0}$, it acts as tetradentate ligand and in complexes $[\text{Ca}(\text{EDTA})]^{2-}$ or $[\text{Mg}(\text{EDTA})]^{2-}$ it acts as hexadentate ligand.

SYMMETRICAL AND UNSYMMETRICAL BIDENTATE LIGANDS

The bidentate ligands in which both the donor atoms are same, are called symmetrical bidentate ligands and the ligands in which both the donor atoms are different are called unsymmetrical bidentate ligands. The symmetrical and unsymmetrical bidentate ligands are represented as (AA) and (AB) respectively where A and B are donor atoms. Examples of symmetrical and unsymmetrical ligands are given below :

Symmetrical Ligands	Unsymmetrical Ligands
$\begin{array}{c} \text{CH}_2 - \text{CH}_2 \\ \quad \\ \text{NH}_2 \quad \text{NH}_2 \\ \text{ethylenediamine, en} \end{array}$	$\begin{array}{c} \text{H}_2\text{N} - \text{CH}_2 - \text{COO}^- \\ \text{glycinato, gly} \end{array}$
$\begin{array}{c} \text{CH}_3 - \text{CH} - \text{CH} - \text{CH}_3 \\ \quad \\ \text{NH}_2 \quad \text{NH}_2 \\ \text{butylenediamine, bn} \end{array}$	<p>8-hydroxyquinolinato</p>
$\begin{array}{c} \text{O} = \text{C} - \text{O}^- \\ \\ \text{O} = \text{C} - \text{O}^- \\ \text{oxalato, ox} \end{array}$	<p>α-nitroso-β-naphthol ion</p>

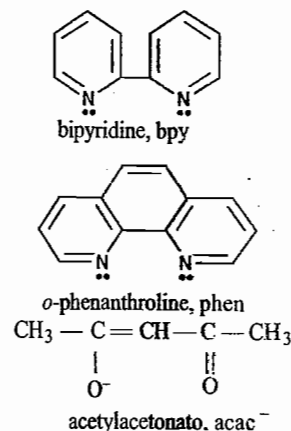

The attachment of symmetrical bidentate ligands to a metal cation can be represented by a curve $A \overset{\curvearrowright}{L}$, where L is the abbreviation of symmetrical bidentate ligand and two A's are two similar donor atoms. The attachment of symmetrical bidentate ligand, ethylenediamine, $\text{NH}_2 - \text{CH}_2 - \text{CH}_2 - \text{NH}_2$, for example, to Co^{3+} ion in $[\text{Co}(\text{en})_3]^{3+}$ ion is shown in Figure 1.7.

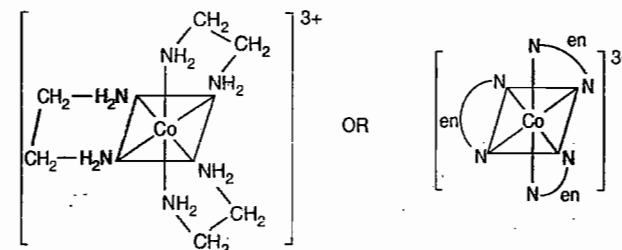

Figure 1.7 Attachment of $\text{NH}_2 - \text{CH}_2 - \text{CH}_2 - \text{NH}_2$ to Co^{3+} ion

Similarly, the attachment of oxalato, $\text{C}_2\text{O}_4^{2-}$ ligand to Fe^{3+} ion is shown in Figure 1.8.

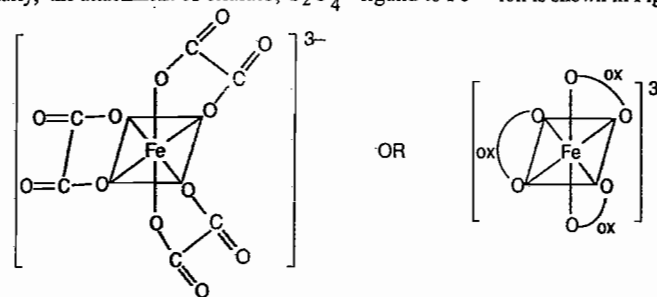

Figure 1.8 Attachment of $\text{C}_2\text{O}_4^{2-}$ ligand to Fe^{3+} ion

The attachment of an unsymmetrical bidentate ligand, AB to the metal cation can be shown by a curve $\begin{matrix} A \\ B \end{matrix} \curvearrowright L$, where L is the abbreviation of the ligand and A and B are two different donor atoms.

The attachment of unsymmetrical bidentate ligand, for example, glycinate, $\text{NH}_2\text{CH}_2\text{COO}^-$ to Co^{3+} ion is shown in Figure 1.9

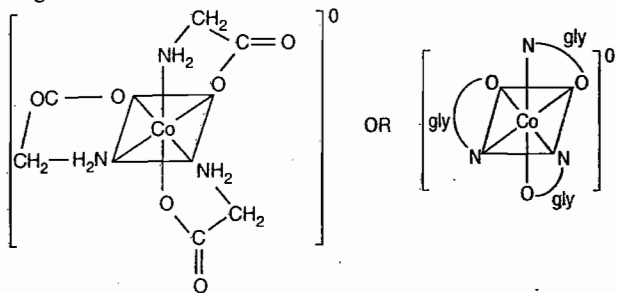

Figure 1.9 Attachment of $\text{NH}_2\text{CH}_2\text{COO}^-$ ligand to Co^{3+} ion.

MACROCYCLIC LIGANDS

These are the special class of chelating ligands. These ligands contain large size rings without a metal cation or atom present. These ligands contain several donor atom inside their ring to donate lone pair of electrons to the metal cation. For example, chlorophyll, hemoglobin and vitamin B_{12} all contain tetradentate macrocyclic ligands.

A macrocyclic ligand form more stable macrocyclic complex as compared to complex formed by the non-cyclic chelating ligands having same number and type of donor atoms as that of macrocyclic ligand. This effect is called macrocyclic effect. It has been observed that the chelate ligands form more stable complexes than analogous monodentate ligands and the chelates of higher denticity (*i.e.*, C.N.) are more stable than the chelates of lower denticity. Also, macrocyclic ligands of appropriate size form more stable complexes than the chelating ligands. This structure of chlorophyll is shown in Figure 1.10.

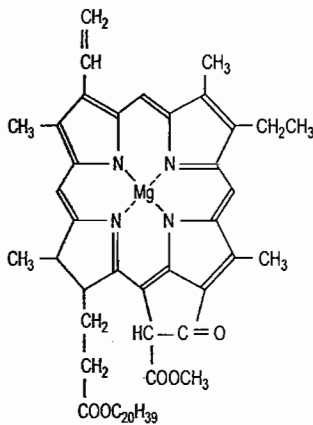

Figure 1.10 Structure of chlorophyll.

HOMOLEPTIC AND HETEROLEPTIC COMPLEXES

Complexes in which a metal is bound to only one kind of donor group, *e.g.*, $[\text{Co}(\text{NH}_3)_6]^{3+}$ are known as homoleptic complexes and the complexes in which a metal is bound to more than one kind of donor groups, *e.g.*, $[\text{Co}(\text{NH}_3)_4\text{Cl}_2]^+$ are known as heteroleptic complexes.

Fill in the Blanks

- NO_2^- is an bidentate ligand.
 - Diethylenetriamine is a tridentate ligand.
 - Coordination number of Mo in $[\text{Mo}(\text{CN})_8]^{3-}$ is 8.
 - The oxidation number of Fe in $[\text{Fe}(\text{H}_2\text{O})_5(\text{NO})]^{2+}$ is +1.
 - In the complex $[\text{Co}(\text{en})_3]^{3+}$, en is bidentate ligand.
 - In the complex $[\text{Ce}(\text{NO}_3)_6]^{2-}$, NO_3^- behaves as bidentate ligand.
 - In the complex $[\text{Co}(\text{en})_2(\text{NO}_2)(\text{NO}_3)]^+$, NO_2^- is an monodentate ligand whereas NO_3^- is not monodentate ligand.
 - Hemoglobin is a type of macrocyclic complex.
 - Pyrazine is a heterocyclic as well as bidentate ligand.
 - EDTA⁴⁻ is a hexadentate ligand.
 - The molar conductance of $[\text{Co}(\text{NH}_3)_6]\text{Cl}_3$ is more than that of $[\text{Co}(\text{NH}_3)_5\text{Cl}]\text{Cl}_2$.
 - Ethylenediamine is a bidentate as well as bidentate ligand.
 - Gly ($\text{NH}_2\text{CH}_2\text{COO}^-$) is an bidentate as well as bidentate ligand.
 - The complex $[\text{Co}(\text{en})_3]^{3+}$ is a type of tridentate.
 - The magnitude of depression in freezing point of 1m aqueous solution of $[\text{Co}(\text{NH}_3)_5\text{Cl}]\text{Cl}_2$ is more than that of 1m aqueous solution of $[\text{Co}(\text{NH}_3)_4\text{Cl}_2]\text{Cl}$.
 - The primary and secondary valencies in $[\text{Co}(\text{NH}_3)_5\text{Cl}]\text{Cl}_2$ are 7 and 2 respectively.
 - The complex $[\text{Fe}(\text{CN})_6]^{3-}$ has 18 electron rule.
 - The complex $[\text{Co}(\text{NH}_3)_6]^{3+}$ obeys 18 EAN rule.
- [Ans. 1. ambidentate 2. tridentate or chelating
3. 8 4. +1
5. bidentate 6. bidentate
7. ambidentate, ambidentate 8. macrocyclic
9. monodentate, bridging 10. hexadentate (chelating)
11. greater 12. symmetric, bidentate
13. unsymmetric, bidentate 14. chelate
15. greater 16. 3, 6
17. does not obey 18. obey]

Objective Questions

1. Which of the following ligands does not behave as ambidentate ligand?

- (a) NO_2^- (b) SCN^-
(c) $\text{S}_2\text{O}_3^{2-}$ (d) NO_3^-

2. Which of the following ligands behaves as an ambidentate ligand?

- (a) NO_3^- (b) SO_3^{2-}
(c) SO_3 (d) ClO_4^-

3. The oxidation state of Rh in $(\text{NH}_4)_3(\text{RhCl}_6)$ is:

- (a) +1 (b) +2
(c) +3 (d) +6

4. Which of the following ligands behaves as a flexidentate ligand?

- (a) NO_3^- (b) SCN^-
(c) CNO^- (d) OH^-

5. Oxidation number of W in MgWO_4 is:

- (a) +2 (b) +3
(c) +4 (d) +6

6. A ligand in metal complexes behaves as:

- (i) electron pair donor (ii) Lewis base
(iii) nucleophile (iv) electrophile

- (a) (i) and (ii) only
(b) (i) and (iii) only
(c) (i), (ii) and (iii) only
(d) All of the above

7. The ligand that exhibits linkage isomerism in its transition metal complexes is:

- (a) $[\text{SO}_3]^{2-}$ (b) $[\text{SO}_4]^{2-}$
(c) $[\text{NO}_3]^-$ (d) $[\text{ClO}_4]^-$

8. Which of the following is not a chelating ligand?

- (a) Thiosulphato (b) Oxalato
(c) Glycinato (d) Ethylenediamine

9. A compound contains 1.08 mol of Na, 0.539 mol of Cu and 2.16 mol of F. Its aqueous solution shows osmotic pressure which is three times that of urea having same molar concentration. The formula of the compound is:

- (a) $\text{Na}_4[\text{CuF}_6]$ (b) $\text{Na}[\text{CuF}_4]$
(c) $\text{Na}_2[\text{CuF}_4]$ (d) $\text{Na}_2[\text{CuF}_3]$

ANSWERS

1. (d) 2. (b) 3. (c) 4. (a) 5. (d) 6. (c) 7. (a)
8. (d) 9. (c)

Subjective Questions

1. How many chelate rings are present in the following complexes?

- (a) $[\text{Ca}(\text{EDTA})]^{2-}$
(b) $[\text{Co}(\text{en})_3]^{3+}$
(c) $[\text{Co}(\text{dien})_2]^{3+}$
(d) $[\text{Cd}(\text{trien})]^{2+}$
(e) $[\text{K}(18\text{-crown-6})]$

2. What is the expected freezing point depression of 0.01 m $[\text{Co}(\text{NH}_3)_6]\text{Cl}_3$ complex?

$$(K_f = -1.86^\circ\text{C/m})$$

3. Arrange the following complexes in the increasing order of:

- (a) conductivity in aqueous solution.
(b) depression in freezing point considering 0.1 m concentration of each complex.

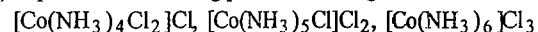

4. A $(2+, 1-)$ electrolyte complex is expected to have higher molar conductivity than $(1+, 1-)$ electrolyte complex. Explain.

5. A solution is made by dissolving 0.875 g of $\text{Co}(\text{NH}_3)_4\text{Cl}_3$ in 25.0 g of water which freezes at -0.56°C . Suggest the structure of this compound. Calculate number of moles of ions produced when one mole of $\text{Co}(\text{NH}_3)_4\text{Cl}_3$ is dissolved in water.

6. Define the following terms:

- (a) Coordination compounds
(b) Ligands
(c) Ambidentate ligands
(d) Chelating ligands
(e) Flexidentate ligands
(f) Bridging ligands
(g) Donor atom
(h) Macrocyclic ligands
(i) Coordination number
(j) Counter ion
(k) Complex ion.

7. What is the coordination number of the metal in each of the following compounds ?

- $[\text{Co(en)}_3]^{3+}$
- $[\text{Co(gly)}_3]$
- $[\text{ZrF}_8]^{4-}$
- $[\text{Ce}(\text{NO}_3)_6]^{2-}$
- $\text{Na}_2[\text{Fe}(\text{CN})_5(\text{NO})]$
- $[\text{Ca}(\text{edta})]^{2-}$
- $[\text{Ni}(\text{Hdmg})_2]$

□□□



2

Structure and Isomerism in Coordination Compounds

Coordination number of a metal ion in its complexes is the number of donor atoms attached to it. Coordination number and geometry of the complexes are related to one another. For example, complexes with coordination number 4 are either tetrahedral or square planar and the complexes with coordination number 6 are octahedral. The coordination number and geometry of the complexes depend upon the following factors :

1. The size of metal ion or atom.
2. Size of the ligands and the steric interaction between the ligands.
3. Electronic interactions and the number of *d*-electrons in metal ion or atom.
4. Whether the ligands form π -bonds with metal ion or not.

In general, the metal atoms or ions of larger size (say 4*d*- and 5*d*- series transition metals and lanthanoids) favour the formation of complexes of higher coordination numbers because steric repulsion decrease with increase in size of central metal cation. For similar reasons, bulky ligands often form complexes of low coordination numbers and the smaller size ligands form complexes of higher coordination number. Complexes of higher coordination numbers are formed for the central metal cation or atom of 4*d*- and 5*d*- transition elements which lie on the left of the period and has a few number of *d*-electrons. The metal cation or atom having a small number of *d*-electrons can accept more electron pairs from the ligands, one example is $[\text{Mo}(\text{CN})_8]^{4-}$. On the other hand, the metal cations which lies on the right of the period and are rich in *d*-electrons form complexes of low coordination numbers. A few examples are $[\text{PtCl}_4]^{2-}$, $[\text{PdCl}_4]^{2-}$, $[\text{AgCl}_2]^-$ etc. These atoms or ions can accept less number of electrons from the ligands. Complexes of low coordination numbers are also formed when the ligands formed multiple bonds with metal cation, such as MnO_4^- , CrO_4^{2-} , $[\text{Ni}(\text{CO})_4]$ etc. The formation of multiple bonds between metal cation and ligands oppose the addition of more number of ligands.

The coordination number of metal ions ranges from 1, as in ion pairs such as Na^+Cl^- in the gaseous state to 12 as in $[\text{Ce}(\text{NO}_3)_6]^{2-}$ ion. In general, the coordination number of metals in complexes are found to be 2 to 9, out of which coordination number 2, 4 and 6 are most common.

Coordination Number 2

A few number of complexes are known with coordination number 2. The complexes with coordination number 2 are given by Cu^+ , Ag^+ , Au^+ and Hg^{2+} ions (*i.e.*, d^{10} -species). These complexes have linear geometry. Some example are :

$[\text{Cu}(\text{NH}_3)_2]^+$, $[\text{CuCl}_2]^-$, $[\text{Cu}(\text{CN})_2]^-$, $[\text{Ag}(\text{NH}_3)_2]^+$, $[\text{Ag}(\text{CN})_2]^-$, $[\text{AgCl}_2]^-$, $[\text{AuCl}_2]^-$, $[\text{Au}(\text{CN})_2]^-$, $[\text{Hg}(\text{CN})_2]$, $[\text{Hg}(\text{CH}_3)_2]$, $[\text{Au}(\text{PR}_3)_2]^+$ etc. These complexes are typically unstable towards the further addition of ligands to form complexes of higher coordination number 3 or 4 such as :

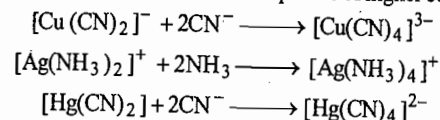

The cyano complexes Ag^+ and Au^+ with coordination number 2 are less stable as they exist as discrete *bis* (cyano) complexes. The solid $\text{K}[\text{Cu}(\text{CN})_2]$ contains a chain like structure (Figure 2.1) in which coordination number of Cu^+ is 3.

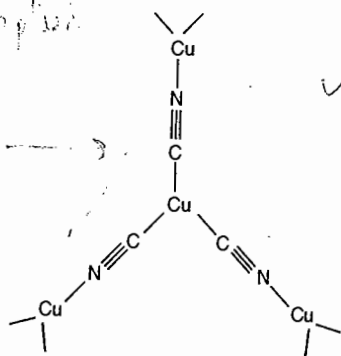

Figure 2.1 Chain structure of $[\text{Cu}(\text{CN})_2]$ in solid form

The complexes of coordination number 2 may also formed by the sterically hindered (*i.e.*, bulky) ligands such as $[\text{N}(\text{SiPh}_3)_2]^-$, $[\text{N}(\text{SiMe}_3)_2]^-$, $[\text{N}(\text{SiMePh}_2)_2]^-$ etc. with the metal ions such as Mn^{2+} , Fe^{2+} , Co^{2+} and Ni^{2+} . One important example is $\text{Fe}[\text{N}(\text{SiPh}_3)_2]_2$.

Coordination Number 3

This coordination number is rare in complexes and the geometries corresponding to coordination number 3 are trigonal planar and trigonal pyramidal. Some famous examples are $\text{K}[\text{Cu}(\text{CN})_2]$ (See Figure 2.1), CsCuCl_3 , infinite single chain, HgI_3^- and the pyramidal SnCl_3^- (Figure 2.2).

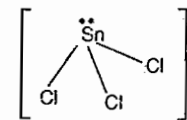
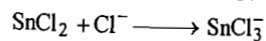

Figure 2.2 Trigonal pyramidal structure of SnCl_3^-

Coordination Number 4

This is the second most important coordination number in coordination chemistry after coordination number 6 which is to be discussed later. The geometry corresponding to the coordination number 4 is tetrahedral or square planar.

Tetrahedral complexes are favoured when the ligands are larger like Cl^- , Br^- , I^- and the central metal cation or atom is smaller with : (i) d^0 and d^{10} -configurations and (ii) d^n -configurations where square planar or octahedral is not favoured by number of d -electrons, such as Fe^{2+} (d^6), Co^{2+} (d^7), Ni^{2+} (d^8), Cu^{2+} (d^9) ions which form tetrahedral complexes with Cl^- , Br^- ions.

The oxoanions of transition metals in high oxidation states are, generally, tetrahedral such as VO_4^{3-} , CrO_4^{2-} , MnO_4^- etc.

Square planar complexes are less favoured sterically than tetrahedral complexes. Therefore, these are prohibitively crowded by large ligands. Co^{2+} ($3d^7$), Ni^{2+} ($3d^8$) and Cu^{2+} ($3d^9$) form square planar complexes with π -acceptor ligands such as CN^- . The metal ions belonging to $4d$ - and $5d$ -series transition elements such as Rh^+ , In^+ , Pd^{2+} , Pt^{2+} , Au^{3+} form invariably square planar complexes regardless of the π -donor or π -acceptor character of the ligands. Examples of square planar complexes are : $[\text{Ni}(\text{CN})_4]^{2-}$, $[\text{Co}(\text{CN})_4]^{2-}$, $[\text{Cu}(\text{CN})_4]^{2-}$, $[\text{Cu}(\text{NH}_3)_4]^{2+}$, $[\text{PdCl}_4]^{2-}$, $[\text{PtCl}_4]^{2-}$, $[\text{AuCl}_4]^-$, $[\text{Rh}(\text{Me}_3\text{P})_3\text{Cl}]$, $[\text{Ir}(\text{CO})(\text{Me}_3\text{P})_2\text{Cl}]$ etc.

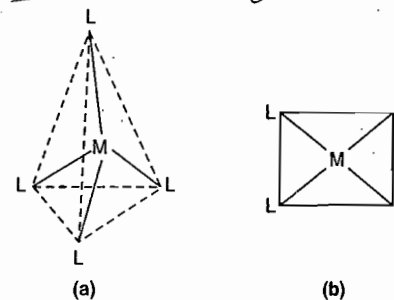
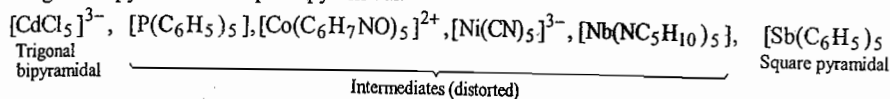

Figure 2.3 (a) Tetrahedral (b) Square planar structure of complexes of coordination number 4

Coordination Number 5

The complexes of coordination number 5 are less common than that of coordination 4 and 6 for d -block elements. The complexes corresponding to coordination number 5 are either square pyramidal

(SP) or trigonal bipyramidal (TBP). However, both these geometries undergo some distortion from their ideal geometries. These two geometries can be interconverted by small change in bond angles because these two geometries often differ little in energy from one another. Muetterties and Guggenberger has produced a series of coordination compounds of coordination number 5 to show a sharp transition of an ideal trigonal bipyramidal to square pyramidal.



In some cases it has been observed that the polydentate ligands or macrocyclic ligands favour the square pyramidal geometry. For example, the iron atom in deoxyhemoglobin and myoglobin has square pyramidal coordination (Figure 2.4).

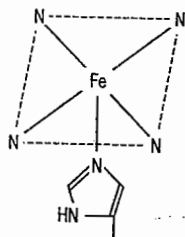

Figure 2.4 The five coordinated Fe(II) deoxyhemoglobin

The $[\text{Ni}(\text{CN})_5]^{3-}$ ion can exist as both square pyramidal [Figure 2.5(a)] and trigonal bipyramidal [Figure 2.5(b)] in the same crystal.



Figure 2.5 (a) Square pyramidal geometry of $[\text{Ni}(\text{CN})_5]^{3-}$ (b) Trigonal bipyramidal geometry of $[\text{Ni}(\text{CN})_5]^{3-}$

In general, trigonal bipyramidal with monodentate ligands are highly fluxional in solution, i.e., a ligand that is equatorial at one moment becomes axial at the next moment. This change in position of ligands may occur by Berry pseudorotation (Figure 2.6)

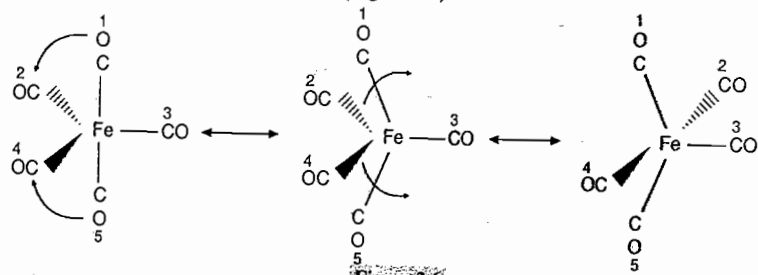

Figure 2.6

The $\text{Fe}(\text{CO})_5$ complex, for example, is trigonal bipyramidal in the crystal, however, in solution the axial and equatorial ligands exchange at a rate such that these ligands can not be distinguished by NMR which has a time scale $\sim 10^{-3}$ s, and the ^{13}C NMR spectrum of $\text{Fe}(\text{CO})_5$ shows only one resonance. This indicates that the exchange of axial and equatorial ligands takes place at a rate that is fast on NMR scale. It is also observed that the exchange of these ligands is slow on IR time scale.

Coordination Number 6

This is the most common and enormously important coordination number for transition metal complexes. The possible geometries corresponding to coordination number 6 may be hexagonal planar, trigonal prismatic, octahedral or tetragonally distorted octahedral. In a regular octahedral complex all the M-L bond distances are equal and the complexes have plane as well as centre of symmetries. In other words, we can say that the regular octahedral complexes are highly symmetric and have O_h symmetry. Examples of some regular octahedral complexes are: Complexes of Cr(III) like $[\text{Cr}(\text{H}_2\text{O})_6]^{3+}$, $[\text{Cr}(\text{CN})_6]^{3-}$, complexes of Co(III) like $[\text{Co}(\text{H}_2\text{O})_6]^{3+}$, $[\text{Co}(\text{NH}_3)_6]^{3+}$, $[\text{Co}(\text{CN})_6]^{3-}$, complexes of Fe^{2+} like $[\text{Fe}(\text{CN})_6]^{4-}$, complexes of Ni^{2+} like $[\text{Ni}(\text{NH}_3)_6]^{2+}$ etc. The structure of regular octahedral complex, say ML_6 is shown in Figure 2.7.

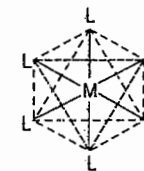

Figure 2.7 Structure of regular octahedral complex

When different kind of ligands are present in an octahedral complex, the symmetry of the true octahedron can not be retained.

There are some complexes of coordination number 6 which have all the six ligands same but undergo some sort of distortion due to the electronic effect. The first is the tetragonal distortion, either elongation or compression along one of the fourfold rotational axes of the octahedral (Figure 2.8). This type of distortion has been discussed in Jahn-Teller distortion or Jahn-Teller effect.

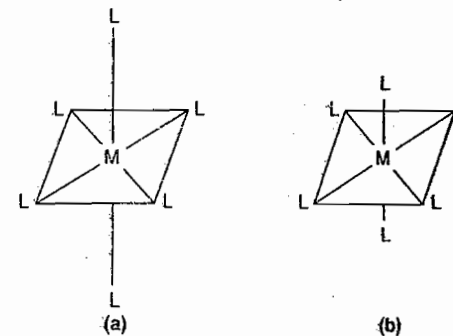

Figure 2.8 Tetragonal distortion: (a) Tetragonal elongation (b) Tetragonal compression

Another type of distortion is the elongation or compression, called trigonal distortion along one of the four threefold rotational axes of the octahedron which pass through the centres of the faces (Figure 2.9) resulting in a trigonal antiprism.

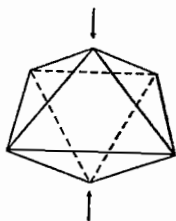

Figure 2.9 Trigonal distortion

If the ligands of a regular octahedral complex like $[\text{Co}(\text{NH}_3)_6]^{3+}$ replaced by chelating ligands like ethylenediamine, $\text{NH}_2 - \text{CH}_2 - \text{CH}_2 - \text{NH}_2$ to form $[\text{Co}(\text{en})_3]^{3+}$, the symmetry of the regular octahedron is reduced from O_h to D_3 but it is not a real distortion.

The complexes having trigonal prismatic geometry (Figure 2.10) are rare, but have been found in crystal lattices of sulphides of heavy metals, for example, MoS_2 and WS_2 . Trigonal prismatic complexes of d^0 configuration such as $[\text{Zr}(\text{CH}_3)_6]^{2-}$ and $[\text{W}(\text{CH}_3)_6]$ have also been isolated. The trigonal prismatic structure of $[\text{Re}(\text{S}_2\text{C}_2\text{Ph}_2)_3]$ is shown in Figure 2.10.

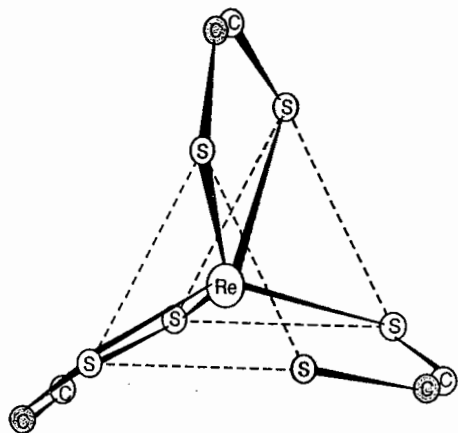

Figure 2.10 Trigonal prismatic geometry in $[\text{Re}(\text{S}_2\text{C}_2\text{Ph}_2)_3]$

Higher Coordination Numbers

Coordination number 7 is not common. However, it is encountered for a few 3d- and some 4d- and 5d- metal complexes, where the larger central metal ion can accommodate more than six ligands. The geometries corresponding to the coordination number 7 are pentagonal bipyramidal, a capped octahedron and a capped trigonal prism (These three geometries are shown in Figure 2.11). In capped octahedron and capped trigonal prism, one ligand (the seventh ligand) occupy one of the eight faces.

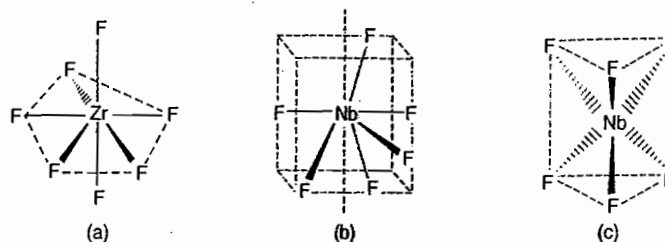

Figure 2.11 (a) Pentagonal bipyramidal (b) Capped octahedron and (c) Capped trigonal prism

Some examples of complexes of coordination number 7 are $[\text{ZrF}_7]^{3-}$, $[\text{Mo}(\text{CNR})_7]^{2+}$, $[\text{ReOCl}_6]^{2-}$ and $[\text{UO}_2(\text{H}_2\text{O})_5]^{2+}$.

Coordination Number 8

Coordination number 8 also can not be regarded as common. The possible geometries for complexes of coordination number 8 are square antiprismatic [Figure 2.12(a)] and the trigonal dodecahedral [Figure 2.12(b)]. The two famous examples with their geometries are shown in Figure 2.12.

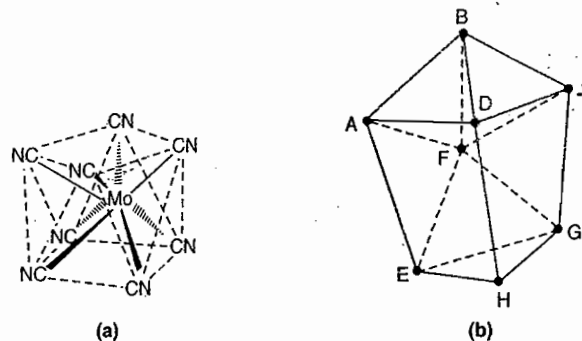

Figure 2.12 (a) Square antiprismatic and (b) Trigonal dodecahedral

Coordination Number 9

Coordination number 9 is shown by some *f*-block elements because of their larger size. Some important examples are $[\text{Ln}(\text{H}_2\text{O})_9]^{2+}$, $[\text{Nd}(\text{H}_2\text{O})_9]^{3+}$. The examples of coordination number 9 of the *d*-block elements are $[\text{TcH}_9]^{2-}$ and $[\text{ReH}_9]^{2-}$. The structure of $[\text{ReH}_9]^{2-}$ is shown in Figure 2.13.

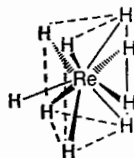

Figure 2.13 Structure of $[\text{ReH}_9]^{2-}$

Coordination Number 10

Coordination number 10 is encountered in complexes of *f*-block M^{3+} ions. For example, in $[\text{Th}(\text{OX})_4(\text{H}_2\text{O})_2]^{4-}$, Th has coordination number of 10. The higher coordination numbers are rare with *d*-block M^{3+} ions because their smaller size may be responsible for the ligand-ligand repulsion when they approach the metal ion.

Coordination Number 12

Coordination number 12 is also encountered in complexes of the *f*-block M^{3+} ions. An important example is $[\text{Ce}(\text{NO}_3)_6]^{2-}$ in which each NO_3^- ligand behaves as bidentate ligand. If the size of a metal cation is small then NO_3^- behaves as monodentate ligand. If, for instance, it acts as bidentate ligand with smaller cation, there will be strain between two donor O-atoms of a NO_3^- and the complex becomes unstable.

If the size of metal cation becomes larger than there will be a small or negligible strain between the two donor O-atom of NO_3^- when it coordinated to metal ion and thus NO_3^- behaves as bidentate ligand.

ISOMERISM

Isomers are compounds with the same chemical composition but different arrangement of their constituent atoms and the phenomenon of existence of isomers is called isomerism. Since their atoms are arranged differently, therefore, isomers are different compounds with different reactivity and/or different physical properties (such as colour, melting and boiling points, and solubility). Isomers are mainly classified into two types. Structural (or constitutional) and stereoisomerism, each of these is further sub classified as:

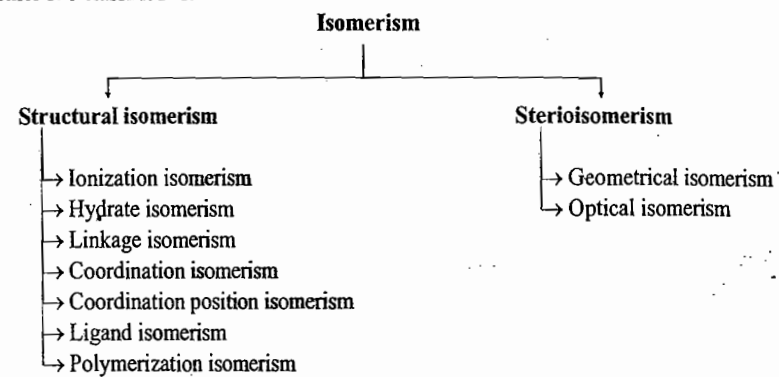

Structural Isomerism

Isomers that have different atom-to-atom bonding are called structural isomers. In coordination compounds, structural isomerism arises due to different connections (or bonding) between metal and ligands.

(1) **Ionization Isomerism**: In these isomers there is exchange of ligands between coordination sphere and ionization sphere (called as counter ion). These isomers give different ions when dissolved in water. For example, $[\text{Co}(\text{NH}_3)_5\text{Br}]\text{SO}_4$ and $[\text{Co}(\text{NH}_3)_5(\text{SO}_4)]\text{Br}$ are ionization isomers. These isomers give different ions in aqueous solution and show different properties.

(a) $[\text{Co}(\text{NH}_3)_5\text{Br}]\text{SO}_4$ is red-violet and $[\text{Co}(\text{NH}_3)_5(\text{SO}_4)]\text{Br}$ is red.

(b) In aqueous solution, $[\text{Co}(\text{NH}_3)_5\text{Br}]\text{SO}_4$ gives white precipitate of BaSO_4 on reaction with BaCl_2 whereas it does not give any precipitate with AgNO_3 . This indicates that SO_4^{2-} ion is present in ionization sphere.

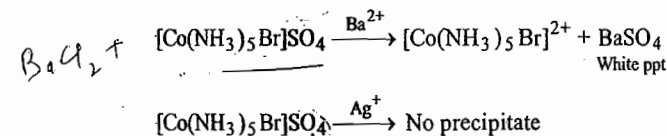

On the other hand, $[\text{Co}(\text{NH}_3)_5(\text{SO}_4)]\text{Br}$ gives cream coloured precipitate of AgBr with AgNO_3 and it does not give any precipitate with BaCl_2 . This indicates that Br^- ion is present outside the coordination sphere.

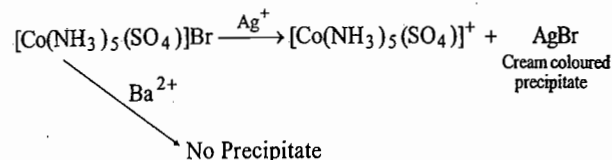

Some other examples of ionization isomerism are :

- (i) $[\text{Co}(\text{NH}_3)_5\text{Cl}]\text{SO}_4$ and $[\text{Co}(\text{NH}_3)_5(\text{SO}_4)]\text{Cl}$
- (ii) $[\text{Co}(\text{NH}_3)_5(\text{NO}_3)]\text{SO}_4$ and $[\text{Co}(\text{NH}_3)_5(\text{SO}_4)]\text{NO}_3$
- (iii) $[\text{Pt}(\text{NH}_3)_4\text{Cl}_2]\text{Br}_2$ and $[\text{Pt}(\text{NH}_3)_4\text{Br}_2]\text{Cl}_2$
- (iv) $[\text{Co}(\text{en})_2\text{Cl}(\text{NO}_2)]\text{SCN}$, $[\text{Co}(\text{en})_2\text{Cl}(\text{SCN})]\text{NO}_2$ and $[\text{Co}(\text{en})_2(\text{NO}_2)(\text{SCN})]\text{Cl}$

(2) **Hydrate Isomerism** : When water molecules are exchanged between coordination sphere and hydration sphere, the resulting isomers are called hydrate isomers. For example, hydrate isomers given by $\text{CrCl}_3 \cdot 6\text{H}_2\text{O}$ are : $[\text{Cr}(\text{H}_2\text{O})_6]\text{Cl}_3$ (violet), $[\text{Cr}(\text{H}_2\text{O})_5\text{Cl}]\text{Cl}_2 \cdot \text{H}_2\text{O}$ (pale green) and $[\text{Cr}(\text{H}_2\text{O})_4\text{Cl}_2]\text{Cl} \cdot 2\text{H}_2\text{O}$ (dark green). These isomers give different properties :

- (i) These isomers have different colours.
- (ii) When these isomers react with AgNO_3 solution, 3, 2 and 1 chloride ions get precipitated respectively.

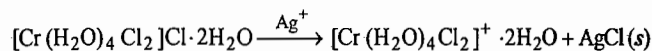
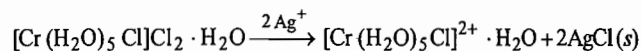
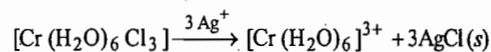

(iii) $[\text{Cr}(\text{H}_2\text{O})_6]\text{Cl}_3$ does not lose water over conc. H_2SO_4 .

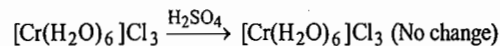

$[\text{Cr}(\text{H}_2\text{O})_5\text{Cl}]\text{Cl}_2 \cdot \text{H}_2\text{O}$ loses one water molecule over conc. H_2SO_4 .

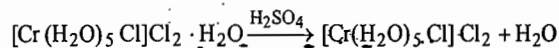

$[\text{Cr}(\text{H}_2\text{O})_4\text{Cl}_2]\text{Cl} \cdot 2\text{H}_2\text{O}$ loses two water molecules over conc. H_2SO_4 .

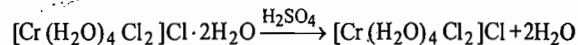

(3) **Linkage Isomerism** : Linkage isomers arise when an ambidentate ligand can coordinate to a metal cation through either of the two different donor atoms.

For example, in complexes containing NO_2^- ion as ligand, it may coordinate to metal cation through either N-atom or O-atom. The linkage isomers containing NO_2^- ion as ligand are : $[\text{Co}(\text{NH}_3)_5(\text{NO}_2)]^{2+}$, N-atom is coordinated to Co^{3+} and $[\text{Co}(\text{NH}_3)_5(\text{ONO})]^{2+}$, O-atom is coordinated to Co^{3+} . Some other examples of linkage isomers are :

- (i) $[\text{Co}(\text{NH}_3)_5(\text{SCN})]\text{Cl}_2$ and $[\text{Co}(\text{NH}_3)_5(\text{NCS})]\text{Cl}_2$
- (ii) $[\text{Co}(\text{en})_2(\text{NO}_2)_2]^+$ and $[\text{Co}(\text{en})_2(\text{ONO})_2]^+$

(iii) $[\text{Pd}(\text{PPh}_3)_2(\text{SCN})_2]$ and $[\text{Pd}(\text{PPh}_3)_2(\text{NCS})_2]$

In most discrete complexes cyanide, CN^- does not behave as an ambidentate ligand. It always bonds through the carbon atom because of the stronger π -bonding in this mode. However, CN^- behaves as ambidentate ligand in linkage isomers such as *cis*- $[\text{Co}(\text{trien})(\text{CN})_2]^+$ and *cis*- $[\text{Co}(\text{trien})(\text{NC})_2]^+$. In large number of polymeric complexes, CN^- acts as ambidentate bridging ligand. For example, in prussian blue and turnbull blue, both have same structure, intensely blue colour, same isocyanide framework as shown below :

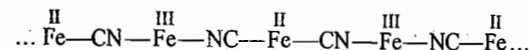

In both prussian blue and turnbull blue, hexacoordinated low spin Fe(II) is bonded through the carbon atoms and hexacoordinated high spin Fe(III) is bonded through the nitrogen atoms of the cyanide. Prussian blue is formed by addition of $\text{K}_4[\text{Fe}(\text{CN})_6]$ solution to Fe^{3+} ions solution.

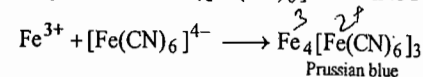

Turnbull blue is formed by addition of $\text{K}_3[\text{Fe}(\text{CN})_6]$ solution to Fe^{2+} ions solution.

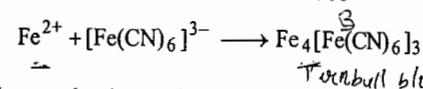

Shriver and *etal* reported an interesting example of linkage isomerism. When $\text{K}_3[\text{Cr}(\text{CN})_6]$ solution is added to $\text{Fe}(\text{II})$ ions solution, a brick red precipitate is obtained which turns dark green on heating at 100°C .

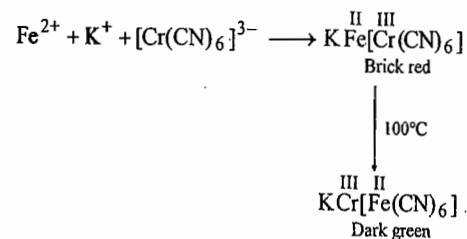

These isomers have the following structures :

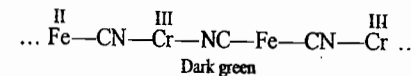
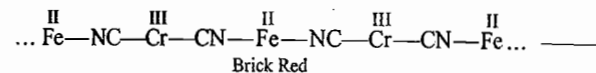

(4) Coordination Isomerism : In complexes when the cation and anion both are complex ions, there may be exchange of ligands between these two complex ions resulting in coordination isomers. In the pairs of these isomers, the central metal cation in the two coordination sphere may be the same or different.

Some examples of coordination isomers are given below :

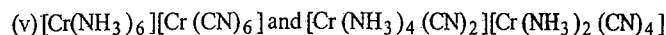
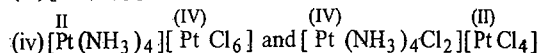
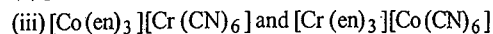
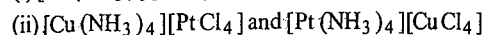
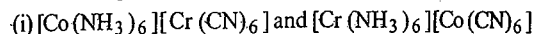

(5) Coordination Position Isomerism : In bridging complexes an exchange of non-bridging ligands between two metal cations give rise to coordination position isomerism.

For example :

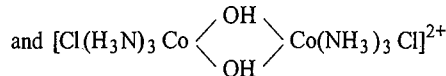
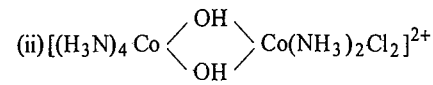
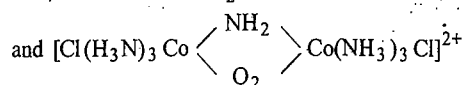
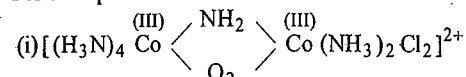

6. Ligand Isomerism : If a ligand itself exists in two or more isomeric forms, then the complexes containing such ligands also exist in isomeric forms. Examples of isomeric ligands are :

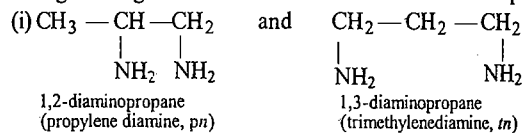

(ii) *o*-, *m*- and *p*-toluidine.

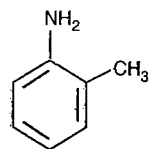

o-toluidine

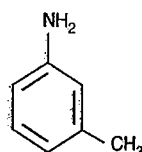

m-toluidine

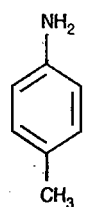

p-toluidine

The two isomers containing ligands *pn* and *tn* are $[\text{Co}(\text{pn})_2\text{Cl}_2]^+$ and $[\text{Co}(\text{tn})_2\text{Cl}_2]^+$ respectively (Figure 2.14).

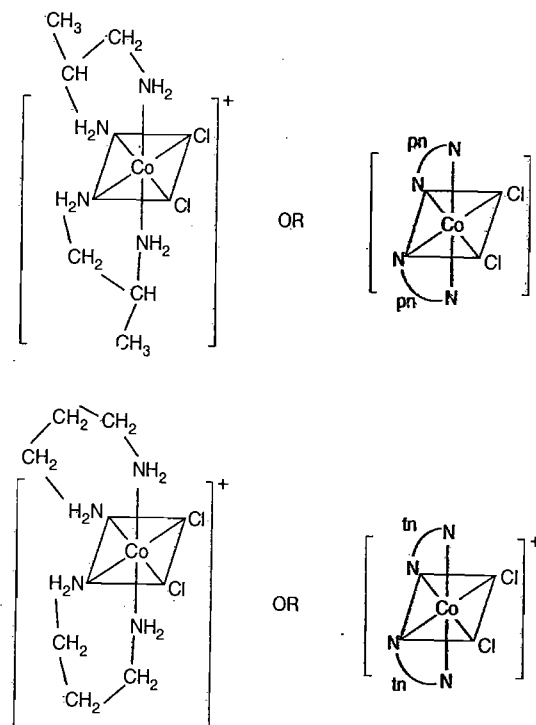

Figure 2.14

7. Polymerization Isomerism : Polymers are not real isomers. These isomers have same empirical formula instead of molecular formula. All these isomers have the same ratio of metal atoms and the ligands in them. Polymerization can be illustrated by the coordination polymers of Pt^{2+} and Co^{3+} ions.

(i) Coordination Polymers of Pt^{2+} ion :

Complex compound	Number of			Ratio
	Pt^{2+}	NH_3	Cl^-	
$[\text{Pt}(\text{NH}_3)_2\text{Cl}_2]$	1	2	2	1 : 2 : 2
$[\text{Pt}(\text{NH}_3)_4][\text{PtCl}_4]$	2	4	4	
$[\text{Pt}(\text{NH}_3)_4][\text{Pt}(\text{NH}_3)\text{Cl}_3]_2$	3	6	6	
$[\text{Pt}(\text{NH}_3)_3\text{Cl}]_2[\text{PtCl}_4]$	3	6	6	

(ii) Coordination Polymers of Co^{3+} ion :

Complex compound	Number of			Ratio
	Co^{3+}	NH_3	NO_2	
$[\text{Co}(\text{NH}_3)_3(\text{NO}_2)_3]$	1	3	3	1 : 3 : 3
$[\text{Co}(\text{NH}_3)_6][\text{Co}(\text{NO}_2)_6]$	2	6	6	
$[\text{Co}(\text{NH}_3)_4(\text{NO}_2)_2][\text{Co}(\text{NH}_3)_2(\text{NO}_2)_4]$	2	6	6	

STEREIOISOMERISM

The isomers in which the same types and number of ligands are coordinated to the metal atom or cation but with different spatial arrangements are called **stereoisomers**. In other words, stereoisomers are isomers that differ only in the spatial arrangement of ligands coordinated to metal cation or atom.

Stereoisomerism is classified into two types :

- (1) Geometrical isomerism
- (2) Optical isomerism

(1) Geometrical Isomerism

Stereoisomers in which the relative positions or orientations of the ligands or more specifically donor atoms round the metal cation is different are called **geometrical isomers** and this phenomenon is called **geometrical isomerism**. Geometrical isomers can not be inter-converted without breaking of M-L bonds. Geometrical isomers exist only in pairs, in one isomer the two particular ligands are adjacent to each other and in the other the two are in opposite sides in the structural formula. Thus, the isomer in which two particular ligands (either identical or non-identical) occupy the adjacent positions of each other is called *cis*-isomer and the isomer in which two particular ligands occupy opposite positions to each other is called *trans*-isomer (The latin word *cis* means next to, *trans* means across). *cis*- and *trans*-isomers are different compounds with different properties like melting points, dipole moments, solubility, colours and chemical properties. For example, *cis*- $[\text{Pt}(\text{NH}_3)_2\text{Cl}_2]$ is polar molecule and is more soluble in water than *trans*- $[\text{Pt}(\text{NH}_3)_2\text{Cl}_2]$ molecule which have zero dipole moment. Also *cis*- $[\text{Pt}(\text{NH}_3)_2\text{Cl}_2]$ called *cis*-platin is an effective anti-cancer drug where as the *trans* isomer is physiologically inactive. Geometrical isomerism is most common in complexes having coordination number of 4 and 6. The complexes which exhibit coordination numbers 2 and 3 do not exhibit geometrical isomerism.

Geometrical isomerism in complexes which exhibit coordination number 4.

(A) **Tetrahedral Complexes** : Tetrahedral complexes do not exhibit geometrical isomerism whether all the ligands are same or different because all the ligands in this geometry are at adjacent positions relative to each other, i.e., each ligand is present at $109^\circ 28'$ from each of the other three ligands.

(B) Square Planar Complexes :

(i) $[\text{Ma}_4]^{n\pm}$, $[\text{Ma}_3\text{b}]^{n\pm}$, $[\text{M}(\text{AA})_2]^{n\pm}$, $[\text{M}(\text{AA})\text{ab}]^{n\pm}$ and $[\text{M}(\text{AA})_2\text{a}_2]^{n\pm}$ type square planar complexes do not exhibit geometrical isomerism because all the possible spatial arrangement of the ligands round the metal cation is the same.

(ii) $[\text{Ma}_2\text{b}_2]^{n\pm}$ type Complexes :

Examples of this type of complexes are : $[\text{Pt}(\text{NH}_3)_2\text{Cl}_2]$, $[\text{Pt}(\text{py})_2\text{Cl}_2]$ etc. which exhibit geometrical isomerism. *cis*- and *trans*- isomers of $[\text{Pt}(\text{NH}_3)_2\text{Cl}_2]$, for example, are shown in Figure 2.15.

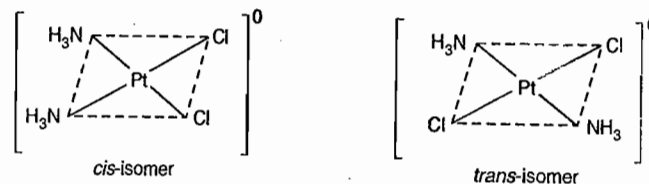

Figure 2.15 *cis*- and *trans*-isomers of $[\text{Pt}(\text{NH}_3)_2\text{Cl}_2]$ square planar complexes.

(iii) $[\text{Ma}_2\text{bc}]^{n\pm}$ type Complexes :

Examples of this type of complexes are : $[\text{Pt}(\text{NH}_3)_2\text{pyCl}]^+$, $[\text{Pt}(\text{py})_2(\text{NH}_3)\text{Cl}]^+$, $[\text{Pt}(\text{NH}_3)_2(\text{NO}_2)\text{Cl}]$ etc. which exhibit geometrical isomerism. *cis*- and *trans*- isomers of $[\text{Pt}(\text{py})_2(\text{NH}_3)\text{Cl}]^+$, for example, are shown in Figure 2.16.

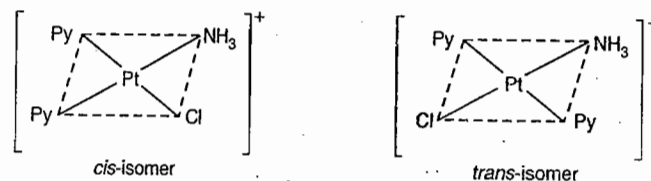

Figure 2.16 *cis*- and *trans*-isomers of $[\text{Pt}(\text{py})_2(\text{NH}_3)\text{Cl}]^+$

(iv) $[\text{Mabcd}]^{n\pm}$ type Complexes :

Square planar complexes of this type exist in three isomeric forms :

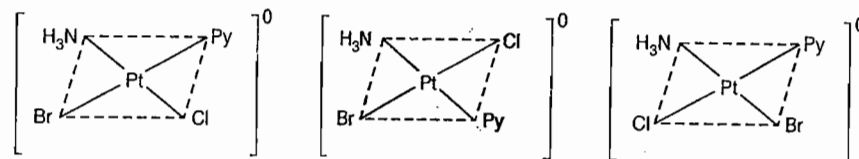

Figure 2.17 Three geometrical isomers of $[\text{Pt}(\text{py})(\text{NH}_3)\text{ClBr}]$

The three isomers of $[\text{Pt}(\text{py})(\text{NH}_3)\text{ClBr}]$, for example, can be obtained by fixing one ligand, say NH_3 , at one corner and then placing the other three ligands, one by one *trans*- to NH_3 Figure 2.17. Some

other examples of such type of square planar complexes which can exist in three isomeric forms are : $[\text{Pt}(\text{C}_2\text{H}_4)(\text{NH}_3)\text{ClBr}]$, $[\text{Pt}(\text{py})(\text{NH}_3)(\text{NH}_2\text{OH})(\text{NO}_2)]^+$ etc.

(v) $[\text{M}(\text{AB})_2]^{n+}$ type Complexes :

Here M is the central metal cation and AB is an unsymmetrical bidentate ligand in which A and B are two different donor atoms. Examples of such type of complexes are : $[\text{Pt}(\text{gly})_2]$, $[\text{Cu}(\text{gly})_2]$ etc. The *cis*- and *trans*- isomers of $[\text{Pt}(\text{gly})_2]$ are shown in Figure 2.18.

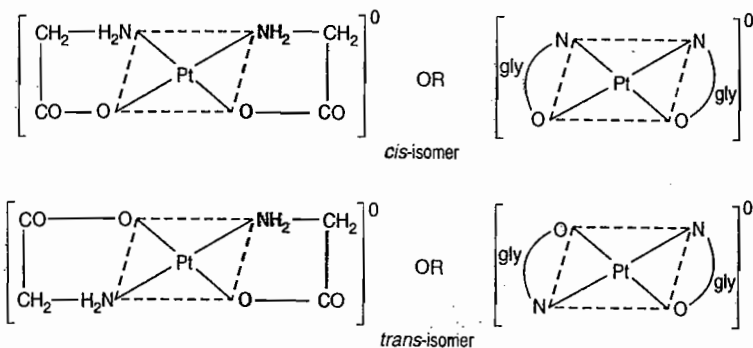

Figure 2.18 *cis*- and *trans*- isomers of $[\text{Pt}(\text{gly})_2]$ where $\text{gly} = \text{NH}_2\text{CH}_2\text{COO}^-$.

(vi) Bridged Binuclear Square Planar Complexes of $\text{M}_2\text{a}_2\text{b}_4$ type :

The bridged binuclear square planar complex of $\text{M}_2\text{a}_2\text{b}_4$ type can exist in three isomeric forms (*cis*-, *trans*- and unsymmetric). The three isomeric forms of $[\text{Pt}(\text{PEt}_3)\text{Cl}_2]_2$, for example, are shown in Figure 2.19. But only *cis*- and *trans*- isomers of most of the complexes of this type have been found.

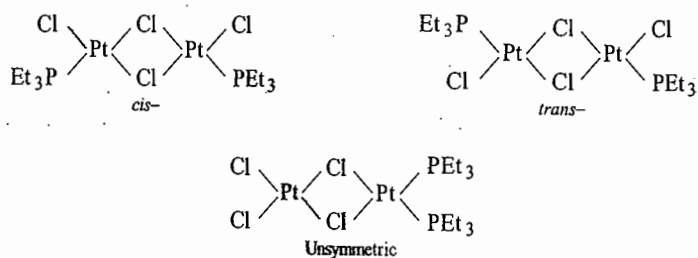

Figure 2.19 Geometrical isomers of $[\text{Pt}(\text{PEt}_3)_2\text{Cl}_2]_2$ binuclear bridged complex.

(vi) Square planar complexes with symmetric bidentate ligands carrying one or more substituents can form geometrical isomers. For example, $[\text{Pt}(\text{pn})_2]^{2+}$ exists in *cis*- and *trans*- isomeric forms (Figure 2.20) in which the methyl groups are *cis*- and *trans*- respectively with respect to the median plane of the ring atoms.

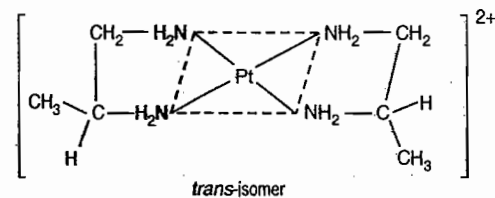
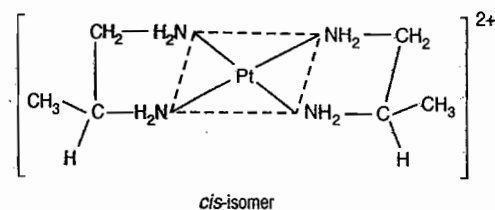

Figure 2.20 *cis*- and *trans*- isomers of $[\text{Pt}(\text{pn})_2]^{2+}$.

Another example of complex is that having bidentate ligands with two methyl substituents as shown in Figure 2.21.

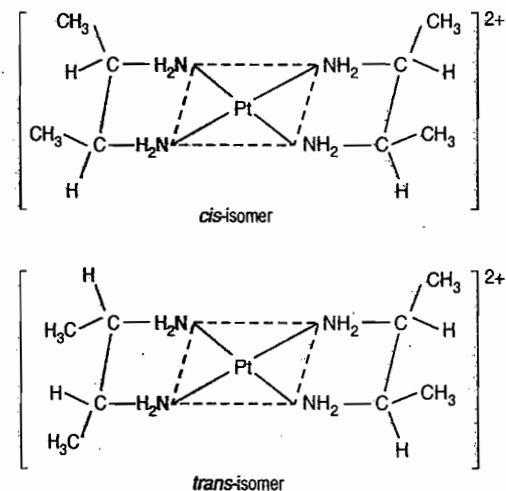

Figure 2.21

Geometrical Isomerism in Octahedral Complexes

In an octahedral complex a metal cation will present in the centre of an octahedron and the six ligands occupy the six corners numbered from 1 to 6 as shown in Figure 2.22.

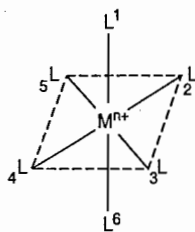

Figure 2.22 Arrangement of six ligands in an octahedral complex around the metal ion M^{n+} .

In *cis*-isomers the two similar ligands or some times two different ligands of interest occupy the corners of octahedron adjacent to one another. In *cis*-isomers the same ligands occupy either of the positions (1,2), (1,3), (1,4), (1,5), (2,3), (3,4), (4,5), (5,2), (6,2), (6,3), (6,4) or (6,5). In *trans*-isomers these ligands are lying opposite to one another on a straight line which passes through the centre of the octahedron. In *trans*-isomers the two ligands under consideration will occupy either of the positions (1,6), (2,4) and (3,5).

Since all the corners of a regular octahedron are equivalent, there are no geometrical isomers of complexes of the type $[Ma_6]^{n\pm}$, $[Ma_5b]^{n\pm}$ and $[M(AA)_3]$ where AA is a symmetric bidentate ligand.

The following types of octahedral complexes exhibit geometrical isomerism :

(i) $[Ma_4b_2]^{n\pm}$ type Complexes :

The complexes of this type exist in *cis*- and *trans*-isomeric forms. Examples of this type of complexes are : $[\text{Co}(\text{NH}_3)_4\text{Cl}_2]^+$, $[\text{Co}(\text{NH}_3)_4(\text{NO}_2)_2]^+$ etc. The *cis*- and *trans*-isomers of $[\text{Co}(\text{NH}_3)_4\text{Cl}_2]^+$ are shown in Figure 2.23.

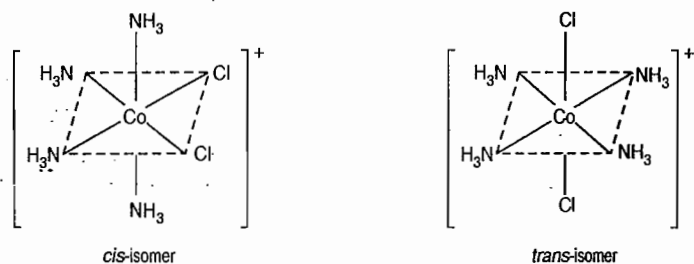

Figure 2.23 *cis*- and *trans*-isomers of $[\text{Co}(\text{NH}_3)_4\text{Cl}_2]^+$ complex ion.

In *cis*-isomers the two Cl^- ligands occupy the adjacent positions (*i.e.*, 1, 2) and in *trans*-isomer the two Cl^- ligands occupy positions opposite to each other (*i.e.*, 1,6). The *cis*-isomer has blue-violet colour whereas *trans*-isomer has green colour.

(ii) $[Ma_4bc]^{n\pm}$ type Complexes :

The complexes of this type also exist in *cis*- and *trans*-isomers. Examples of this type of complexes are : $[\text{Co}(\text{NH}_3)_4(\text{H}_2\text{O})\text{Cl}]^{2+}$, $[\text{Co}(\text{NH}_3)_4(\text{py})\text{Cl}]^{2+}$ etc. The *cis*- and *trans*-isomers of $[\text{Co}(\text{NH}_3)_4(\text{H}_2\text{O})\text{Cl}]^{2+}$ are shown in Figure 2.24.

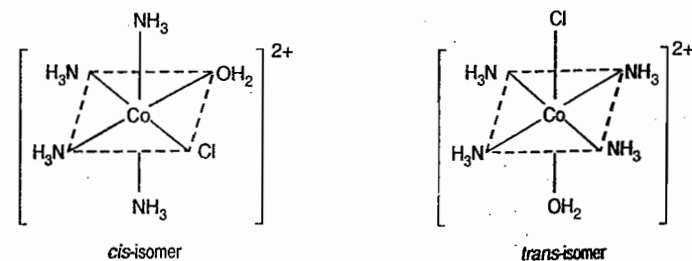

Figure 2.24 *cis*- and *trans*-isomers of $[\text{Co}(\text{NH}_3)_4(\text{H}_2\text{O})\text{Cl}]^{2+}$ complex ion.

In *cis*-isomer H_2O and Cl^- ligands are at adjacent positions whereas in *trans*-isomers these ligands are on opposite positions.

(iii) *Facial and Meridional Isomers* :

In *facial* isomers three identical donor atoms lie on the corners of a **triangular face** and in *meridional* isomers three identical donor atoms lie on the corners of a plane bisecting the complex. There are four types of complexes which exist in *fac*- and *mer*-isomeric forms.

(a) $[Ma_3b_3]^{n\pm}$ type Complexes :

Some examples of this type of complexes are : $[\text{Co}(\text{NH}_3)_3\text{Cl}_3]$, $[\text{Co}(\text{NH}_3)_3(\text{NO}_2)_3]$, $[\text{Cr}(\text{NH}_3)_3\text{Cl}_3]$ etc. *Facial* (or *cis*-) and *meridional* (or *trans*-) isomers of $[\text{Co}(\text{NH}_3)_3\text{Cl}_3]$ are shown in Figure 2.25.

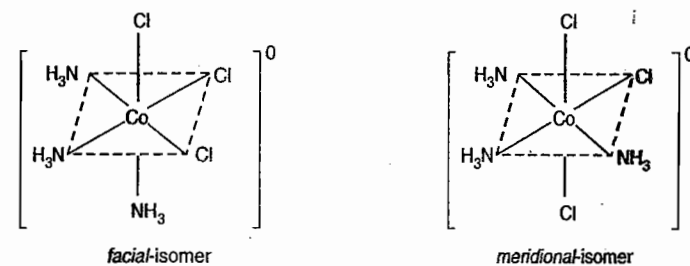

Figure 2.25 *fac*- and *mer*-isomers of $[\text{Co}(\text{NH}_3)_3\text{Cl}_3]^0$ complex ion.

In *fac*-isomer, the three $\text{Cl}-\text{Co}-\text{Cl}$ bond angles are 90° while in the *mer*-isomer, two $\text{Cl}-\text{Co}-\text{Cl}$ bond angles are 90° and one is 180° . Also we can say that in *mer*-isomer three Cl^- ligands lie in one plane and three NH_3 ligands lie in a perpendicular plane. This complex is called **meridional** because each set of ligands can be regarded as lying on a meridian of a sphere (the largest circle that can be drawn on the surface of the sphere).

(b) $[M(\text{AB})_3]^{n\pm}$ type Complexes :

In this type of complexes AB is an unsymmetric bidentate ligand. Well known example of this type of complexes are : $[\text{Co}(\text{gly})_3]$ and $[\text{Cr}(\text{gly})_3]$, where $\text{gly} = \text{NH}_2\text{CH}_2\text{COO}^-$. The *facial* and *meridional* isomers of $[\text{Co}(\text{gly})_3]$ are shown in Figure 2.26.

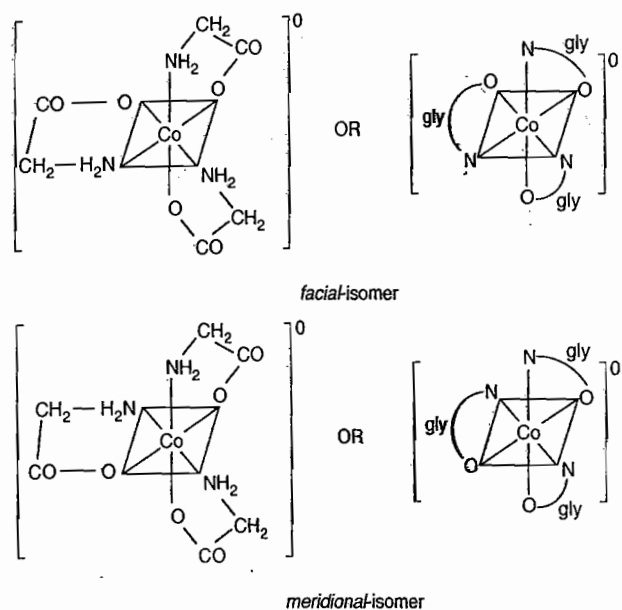

Figure 2.26 facial and meridional isomers of $[\text{Co}(\text{gly})_3]_0$

In *facial* isomer three N-donor atoms occupy the corners of a trigonal face and the three O-donor atoms occupy the corners of another trigonal face and in other words, we can say that in the *facial* isomer, the three possible N—Co—N bond angles are 90° . In *meridional* isomer two N—Co—N bond angles are 90° and one is 180° .

(c) The complex $[\text{Co}(\text{dien})(\text{NO}_2)_3]$ (Where $\text{dien} = \text{NH}_2 - \text{CH}_2 - \text{CH}_2 - \text{NH} - \text{CH}_2 - \text{CH}_2 - \text{NH}_2$) also exists in *facial* and *meridional* isomeric forms as shown in Figure 2.27.

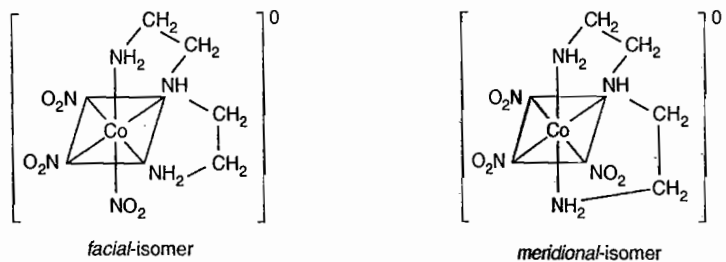

Figure 2.27 fac- and meridional isomers of $[\text{Co}(\text{dien})(\text{NO}_2)_3]$

(d) The complex $[\text{Co}(\text{dien})_2]^{3+}$ also exists as *facial*- and *meridional*- isomers as shown in Figure 2.28.

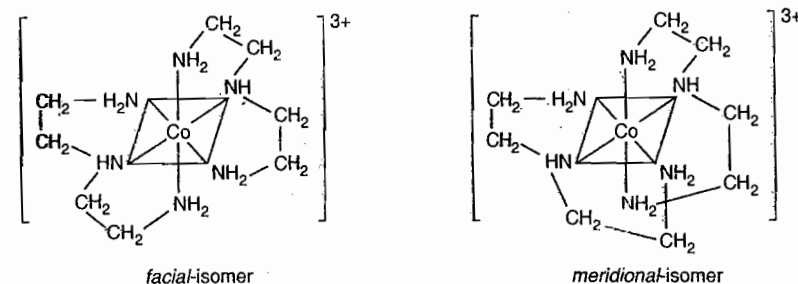

Figure 2.28 facial and meridional isomers of $[\text{Co}(\text{dien})_2]^{3+}$ ion

In *facial* isomers the three N-donor atoms of a dien ligand lie on the corners of a trigonal face *i.e.*, the three possible N—Co—N bond angles for a dien ligand are 90° . In a *meridional* isomer two N—Co—N bond angles and one N—Co—N bond angle for a dien ligand are 90° and 180° respectively.

(iv) $[\text{Ma}_2\text{b}_2\text{c}_2]^{n\pm}$ type Complexes :

The complex ion, $[\text{Pt}(\text{NH}_3)_2(\text{Py})_2\text{Cl}_2]^{2+}$ is an example of $[\text{Ma}_2\text{b}_2\text{c}_2]^{n\pm}$ type complexes. The possible geometrical isomers are shown in Figure 2.29.

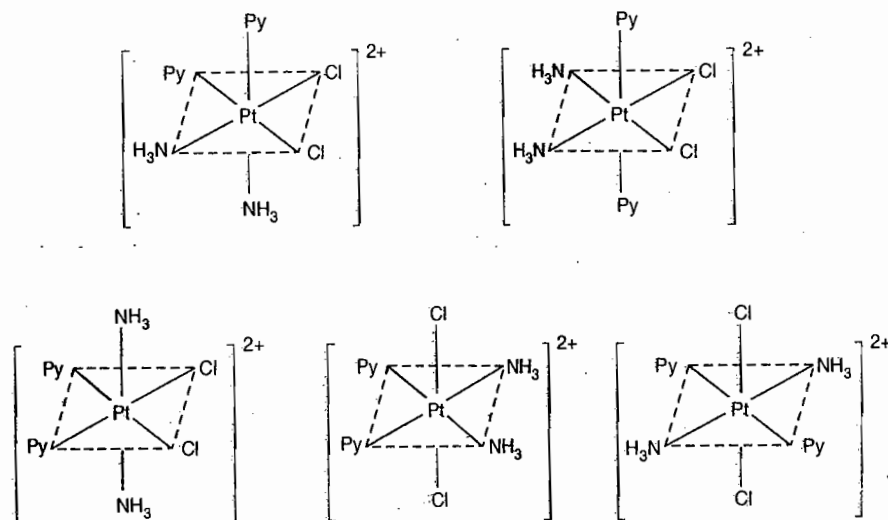

Figure 2.29 All the five possible geometrical isomers of $[\text{Pt}(\text{NH}_3)_2(\text{py})_2\text{Cl}_2]^{2+}$

(v) $[M abcdef]^{n\pm}$ type Complexes : $[Pt(py)(NH_3)(NO_2)(Cl)(Br)(I)]$

There is only one coordination compound, of this type. This compound can exist in fifteen possible isomeric forms but only three isomers have been isolated.

(vi) $[M(AA)_2 a_2]^{n\pm}$ type Complexes :

Here AA is a symmetric bidentate ligand, and 'a' is a monodentate ligand. Some example of this type of complexes are : $[Co(en)_2Cl_2]^+$, $[Co(en)_2(NO_2)_2]^+$, $[Co(en)_2(NO_3)_2]^+$, $[Rh(C_2O_4)_2Cl_2]^{3-}$ etc. The possible geometrical isomers $[Co(en)_2Cl_2]^+$ are shown in Figure 2.30.

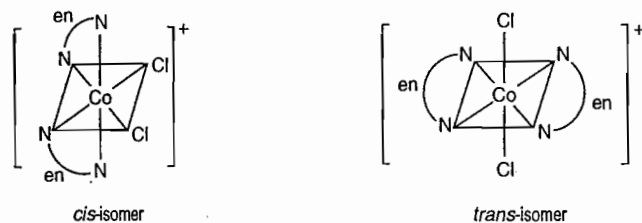
Figure 2.30 Geometrical isomers of $[Co(en)_2Cl_2]^+$ ion(vii) $[M(AA)_2 ab]^{n\pm}$ type Complexes :

Some examples of this type of complexes are : $[Co(en)_2(NH_3)Cl]^{2+}$, $[Co(en)_2(py)Cl]^{2+}$, $[Cr(OX)_2(NO_2)Cl]^{3-}$ etc. The geometrical isomers of $[Co(en)_2(NH_3)Cl]^{2+}$ are shown in Figure 2.31.

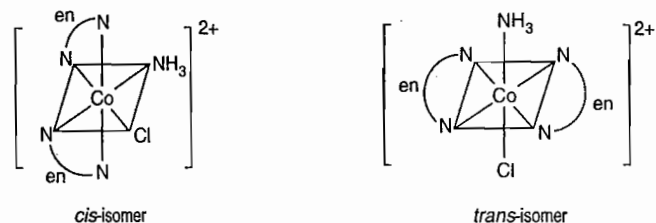
Figure 2.31 *cis*- and *trans*-isomers of $[Co(en)_2(NH_3)Cl]^{2+}$ ion

In *cis*- isomer the ligands NH_3 and Cl^- are at adjacent positions whereas in *trans*- isomer the ligand NH_3 and Cl^- are opposite to one another.

(viii) $[M(AA)_2 a_2 b_2]^{n\pm}$ type Complexes :

Some examples of this type of complexes are : $[Co(en)(NH_3)_2Cl_2]^+$, $[Co(en)(py)_2Cl_2]^+$ etc. The possible geometrical isomers of $[Co(en)(NH_3)_2Cl_2]^+$ are shown in Figure 2.32.

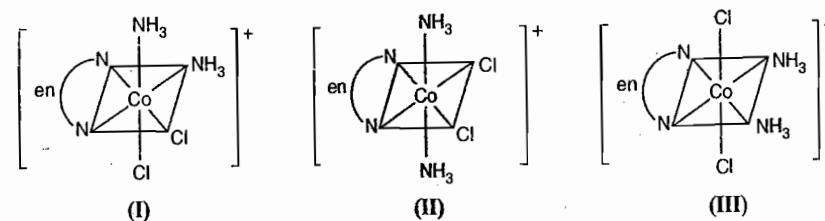
Figure 2.32 Geometrical isomers of $[Co(en)(NH_3)_2Cl_2]^+$ ion

In isomer (I) both the NH_3 ligands and both the Cl^- ligands are on adjacent positions. In isomer (II), the NH_3 ligands are opposite and the Cl^- ligands are on the adjacent positions whereas in isomer (III) the Cl^- ligands are opposite and the NH_3 ligands are on adjacent positions.

(IX) $[M(AB)_2 a_2]^{n\pm}$ type Complexes :

An example of this type of complexes is $[Co(gly)_2Cl_2]^-$ ion. The geometrical isomers of this complex are shown in Figure 2.33.

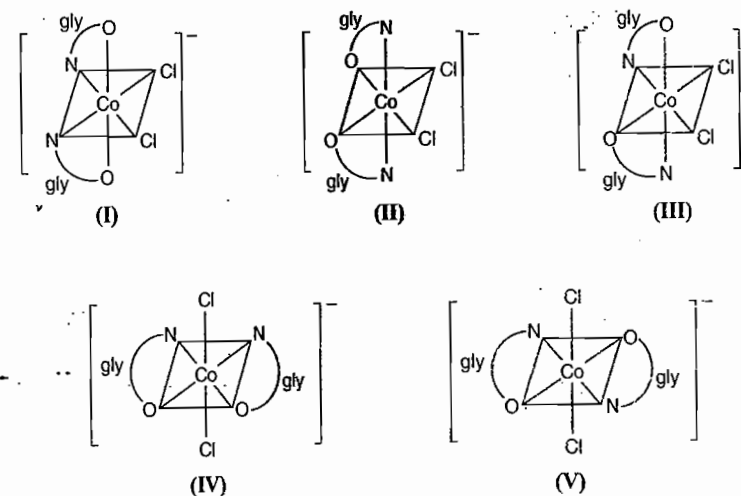
Figure 2.33 Geometrical isomers of $[Co(gly)_2Cl_2]^-$ ion(X) $[M(AB)_2 ab]^{n\pm}$ type Complexes :

An example of this type of complexes is $[Co(gly)_2(NH_3)(py)]^+$ ion. The geometrical isomers of this complex ion are shown in Figure 2.34.

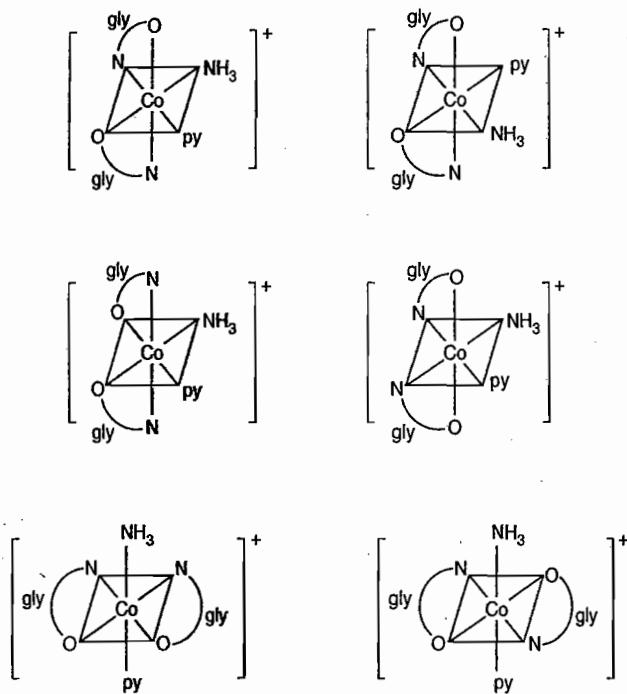
Figure 2.34. Six possible geometrical isomers of $[\text{Co}(\text{en})(\text{pn})(\text{NH}_3)(\text{gly})]^+$ ion.**(XI) Octahedral Complexes Containing Optically Active Bidentate Ligand like, *pn* :**

An important example of this type of complex is $[\text{Co}(\text{en})(\text{pn})(\text{NO}_2)_2]^+$ ion.

where $\text{en} \rightarrow \begin{array}{c} \text{CH}_2 - \text{CH}_2 \\ | \quad | \\ \text{NH}_2 \quad \text{NH}_2 \end{array}$ (ethylenediamine)

and $\text{pn} \rightarrow \begin{array}{c} \text{CH}_3 - \text{CH} - \text{CH}_2 \\ | \quad | \\ \text{NH}_2 \quad \text{NH}_2 \\ ** \quad * \end{array}$ (propylenediamine)

The possible geometrical isomers of $[\text{Co}(\text{en})(\text{pn})(\text{NO}_2)_2]^+$ ion are shown in Figure 2.35.

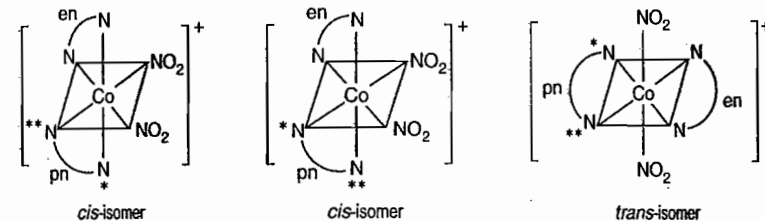
Figure 2.35. Geometrical isomers of $[\text{Co}(\text{en})(\text{pn})(\text{NO}_2)_2]^+$ ion.

There are two *cis*-isomers and only one *trans*-isomer i.e., there are only three geometrical isomers for $[\text{Co}(\text{en})(\text{pn})(\text{NO}_2)_2]^+$ ion. Since *pn* is an unsymmetric optically active bidentate ligand, its donor N-atoms are differentiated by marking one and two asterisks.

(XII) Polynuclear Complexes :

The geometrical isomers of dinuclear bridged octahedral complex of Fe (II), viz. $[\text{Fe}_2(\text{OH})_4(\text{H}_2\text{O})_6]^{2+}$ are shown in Figure 2.36.

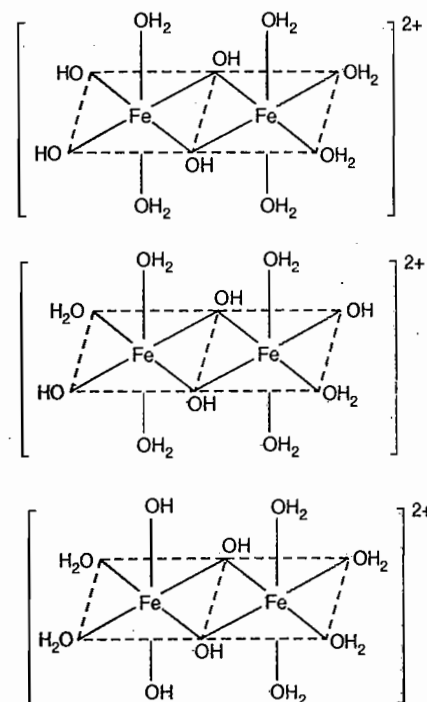
Figure 2.36. Three possible geometrical isomers of $[\text{Fe}_2(\text{OH})_4(\text{H}_2\text{O})_6]^{2+}$ ion.

To Distinguish *cis*- and *trans*-Isomers

The *cis*- and *trans*- isomers can be distinguished by the following methods :

(i) **Dipole Moment Measurements** : The *trans*- isomers has dipole moments equal to zero because the dipole moment of one M-L bond is cancelled by the dipole moment of other M-L bond lying on the opposite side. In *cis*-isomers the dipole moments of two M-L bonds (which are *cis*- to one another) contribute in the same direction resulting in a some value of dipole moment.

(ii) **Infrared Spectroscopy** : In order for a molecule to absorb infrared radiations to cause vibrations, there must be a change in the dipole moment of the molecule as it vibrates. In case of *trans* complexes such as $[\text{Pt}(\text{NH}_3)_2\text{Cl}_2]$ and $[\text{Co}(\text{NH}_3)_4\text{Cl}_2]^+$, the Cl-metal-Cl symmetric stretching causes no change in the dipole moment of the molecule (see Figure 2.37). Therefore, these two compounds are IR inactive and no band corresponding to symmetric stretching vibrations is observed in the infrared spectrum. In case of the *cis*- isomers of these complexes both the symmetric and asymmetric stretching vibrations of Cl-metal-Cl bonds cause appreciable changes in dipole moment. Thus, these mode of vibrations for *cis*- complexes are IR active and there are a number of bands in the infrared spectrum.

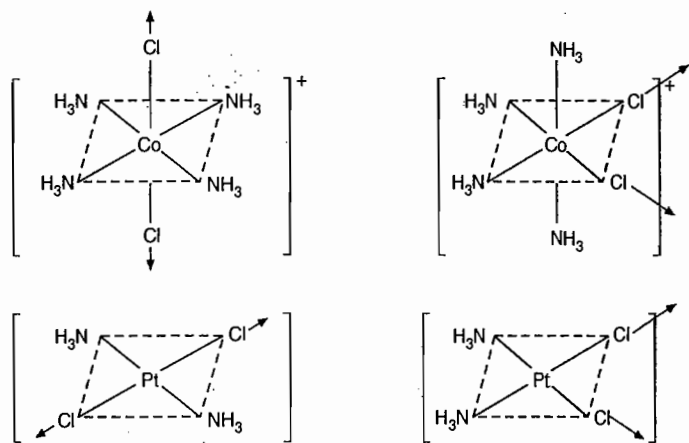

Figure 2.37

(iii) Chemical Method : Grinberg's Method :

When a chelating ligand such as $\text{NH}_2\text{CH}_2\text{COOH}$, COOH , $\text{NH}_2-\text{CH}_2-\text{CH}_2-\text{NH}_2$ etc. reacts



with *cis*- and *trans*- isomers separately, the *cis*- isomer forms a chelated complex or chelate and the *trans* isomer form a non-chelated complex. The reactions of, for example, *cis*- and *trans*- $[\text{Pt}(\text{NH}_3)_2\text{Cl}_2]$ with $\text{C}_2\text{O}_4^{2-}$ and $\text{NH}_2\text{CH}_2\text{COO}^-$ are shown in Figure 2.38.

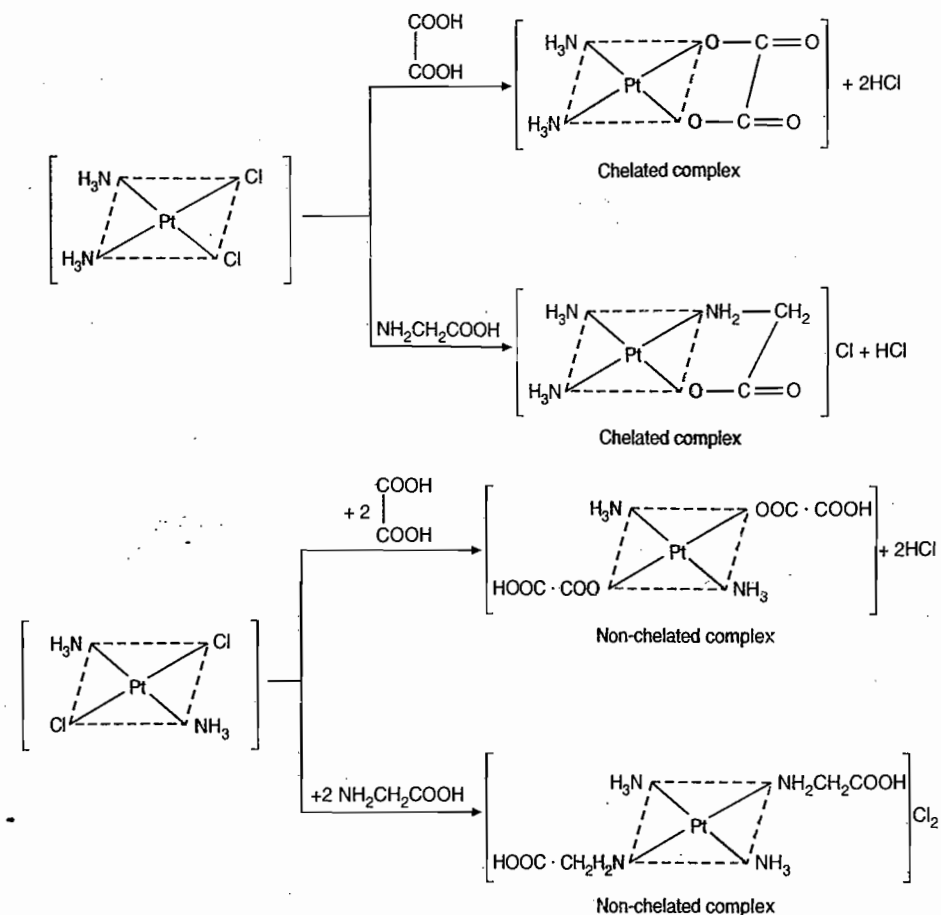

Figure 2.38

Quantitatively it is observed that for one mole of *cis*- isomer, one mole of $\text{NH}_2\text{CH}_2\text{COOH}$ or COOH



is used whereas for one mole of *trans*- isomer two moles of either $\text{NH}_2\text{CH}_2\text{COOH}$ or COOH is used.



cis- isomer forms chelate with chelating ligands because the two donor atoms coordinate on adjacent positions resulting in less strain. But in case of *trans*- isomer, the donor atoms of chelating ligands can not coordinate at the *trans*- positions because of large strain. This large strain causes the instability of the chelated complex.

OPTICAL OR MIRROR IMAGE ISOMERISM

Optical isomers or enantiomers are pairs of molecules or ions which are non-superimposable mirror images of each other. The term superimposable means that if one structure is laid over the other of the same molecule, the positions of all the atoms will match and the term non-superimposable means that if one structure is laid over the other of the same molecule, the positions of all the atoms will not match. For example, if a pipette is placed in front of a mirror, the image reflected is identical to the pipette itself. The pipette and its mirror image both are superimposable. If the left hand is placed in front of a mirror, the image reflected will look like the right hand. Thus, we can say that the left hand and right hand are mirror image of each other. However, they are non-superimposable because when left hand is placed over right hand keeping both palms down, they do not match. The non-superimposable property of left and right hands is called handedness. The optical isomers have handedness and are said to be chiral (pronounced ky-ral, from the greek word, cheir, meaning hand) because like left and right hands, chiral molecules are non-superimposable. Isomers that are superimposable (i.e., that lack handedness) with their mirror images are said to be non-chiral or achiral. Chiral molecules are optically active because they rotate the plane of plane polarized light as it passes through the solutions of them. Unlike ordinary light, which vibrates in all directions, plane polarized light vibrates only in single plane. Plane polarized light is obtained by passing ordinary light through polarizing filter (i.e., nicol prism) which is made up of quartz, CaF_2 . When plane polarized light is passed through the solution of a chiral compound the plane of polarization is rotated either to the right or to the left. If the plane of polarization is rotated to right, the isomer is said to be dextrorotatory (d or $+$), if the plane of polarization is rotated to left, the isomer is said to be levorotatory (l or $-$). The d - and l - isomers of a chiral substance are called enantiomers. The d - and l - isomers rotate the plane of polarized light by the equal amount but in opposite directions. An equimolar mixture of d - and l - isomers, called a racemic mixture produces no net optical rotation because the rotations produced by the individual enantiomers is exactly cancelled.

The essential condition for a substance to be chiral (or optically active) is that the substance has no plane of symmetry. If a substance has a plane of symmetry, then it will be achiral (or optically inactive). The substances having no plane of symmetry (or mirror plane symmetry) are always non-superimposable on their mirror images.

OPTICAL ISOMERISM IN SQUARE PLANAR COMPLEXES

Square planar complexes rarely show optical isomerism whether all the four ligands are different or same because they have all the four ligands and the metal cation in the same plane and hence have a plane of symmetry. However, there are exceptionally some complexes which exhibit optical isomerism. For example, (isobutylenediamine) (meso-diphenylethylenediamine) palladium (II) or platinum (II) complexes (also called as isobutylenediamine meso-stilbenediamine palladium (II) or platinum (II) complexes) are square planar structures and are optically active. The optical isomers of Pt (II) or Pd (II) square planar complex are shown in Figure 2.39

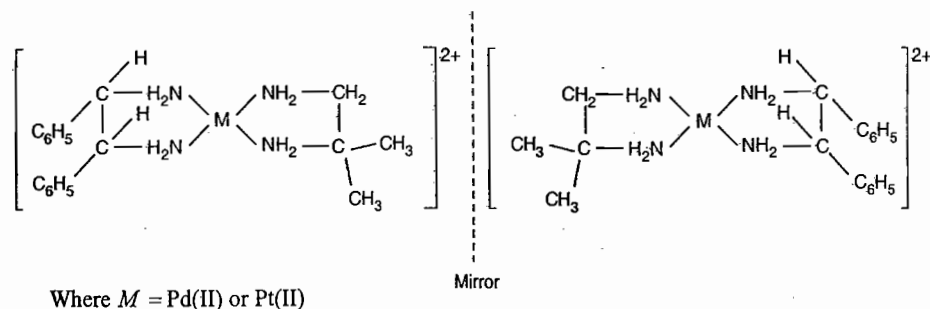

Figure 2.39 Optical isomers of square planar isobutylenediamine-meso-stilbenediamine palladium (II) or platinum (II) complexes.

Ethylenediaminetetraacetate, EDTA^{4-} forms a square planar complex ion with palladium (II) in which EDTA^{4-} acts as a tetradentate ligand. This complex ion exists as optical isomers as shown in Figure 2.40.

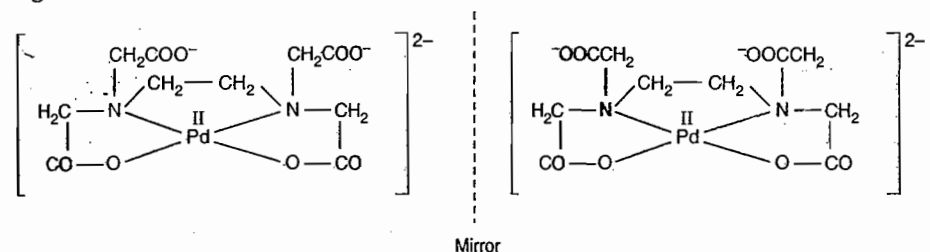

Figure 2.40 Optical isomers of $[\text{Pd}(\text{EDTA})]^{2-}$ ion.

Tetrahedral Complexes :

Tetrahedral complexes of $[\text{Ma}_4]^{n\pm}$, $[\text{Ma}_2\text{b}_2]^{n\pm}$ and $[\text{Ma}_3\text{b}]^{n\pm}$ type do not show optical isomerism because all the possible arrangements of the ligands round the metal cation are the same. However, $[\text{Mabcd}]^{n\pm}$ type tetrahedral complexes show optical isomerism. For example, $[\text{As}^{3+}(\text{CH}_3)(\text{C}_2\text{H}_5)(\text{S})(\text{C}_6\text{H}_5\text{COO})]^{2+}$ ion show optical isomers as shown in Figure 2.41.

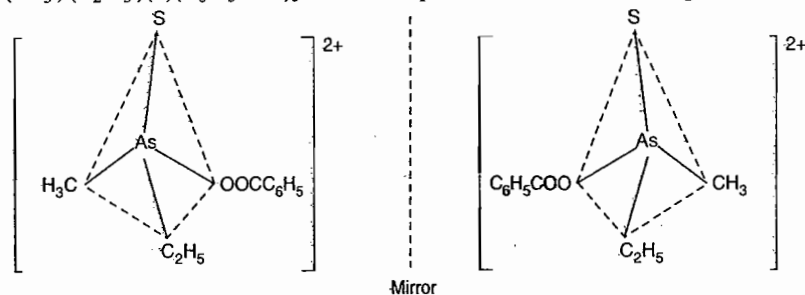

Figure 2.41 Optical isomers of $[\text{As}^{3+}(\text{CH}_3)(\text{C}_2\text{H}_5)(\text{S})(\text{C}_6\text{H}_5\text{COO})]^{2+}$ ion. The complex $[\text{As}^{3+}(\text{CH}_3)(\text{C}_2\text{H}_5)(\text{S})(\text{C}_6\text{H}_5\text{COO})]^{2+}$ has no plane of symmetry, hence is optically active.

$[\text{As}^{3+}(\text{CH}_3)(\text{C}_2\text{H}_5)(\text{S})(\text{C}_6\text{H}_5\text{COO})]^{2+}$

$[\text{As}^{3+}(\text{CH}_3)(\text{C}_2\text{H}_5)(\text{S})(\text{C}_6\text{H}_5\text{COO})]^{2+}$

$[\text{As}^{3+}(\text{CH}_3)(\text{C}_2\text{H}_5)(\text{S})(\text{C}_6\text{H}_5\text{COO})]^{2+}$

Tetrahedral complexes of Be (II), B (III) and Zn (II) with unsymmetric chelating ligand also exist as optical isomers. For example, optical isomers of *bis* (benzoylacetonato) beryllium are shown in Figure 2.42.

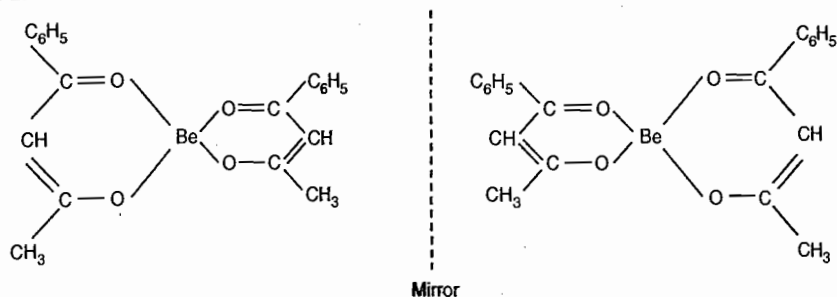

Figure 2.42 Optical isomers of *bis* (benzoylacetonato) beryllium (II)

Optical Isomerism in Octahedral Complexes :

Octahedral complexes of the type of $[Ma_6]^{n\pm}$, $[Ma_5b]^{n\pm}$ are optically inactive and do not show optical isomerism because of the presence of plane of symmetry (Figure 2.43). For example, $[Co(NH_3)_6]^{3+}$ and $[Co(NH_3)_5Cl]^{2+}$ ions both have plane of symmetry and hence are optically inactive.

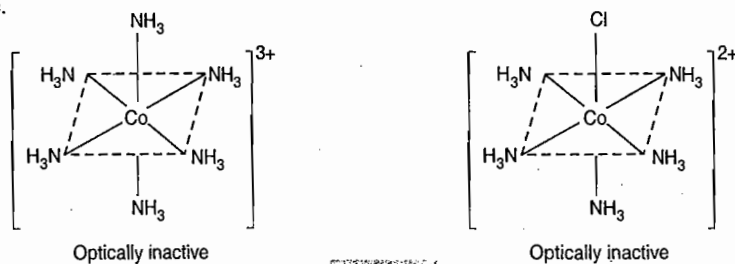

Figure 2.43

(i) $[Ma_4b_2]^{n\pm}$ type Complexes : An important example of this type of complexes is $[Co(NH_3)_4Cl_2]^+$ ion which exists in *cis*- and *trans*- isomeric forms (Figure 2.44). Both these forms have plane of symmetry and therefore, are optically inactive. Thus, this type of complexes do not show optical isomerism.

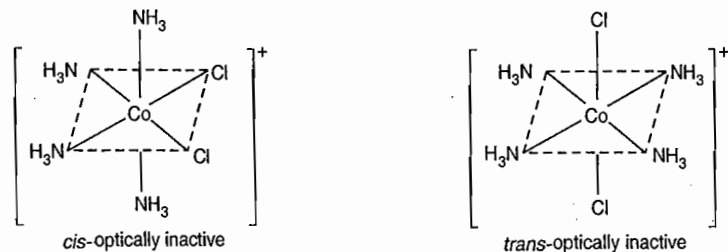

Figure 2.44

(ii) $[Ma_4bc]^{n\pm}$ type Complexes : An important example of this type of complexes is $[Co(NH_3)_4(H_2O)Cl]^{2+}$ ion. This complex ion exists in *cis*- and *trans*- forms (Figure 2.45). Both these forms are achiral. Therefore, these forms do not show optical isomerism.

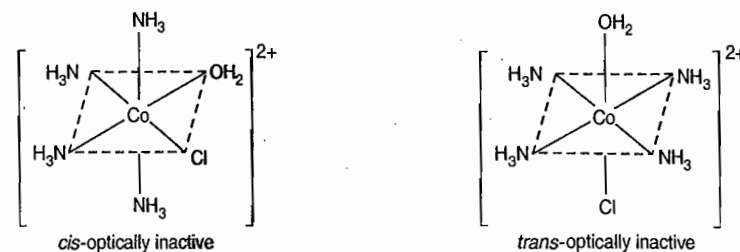

Figure 2.45

(iii) $[Ma_3b_3]^{n\pm}$ type complexes : An important example of this type of complexes is $[Co(NH_3)_3Cl_3]$. This complex exists in *facial* (i.e., *cis*-) and *meridional* (i.e., *trans*-) forms (Figure 2.46). Both these forms are achiral and optically inactive. Therefore, these forms do not show optical isomerism.

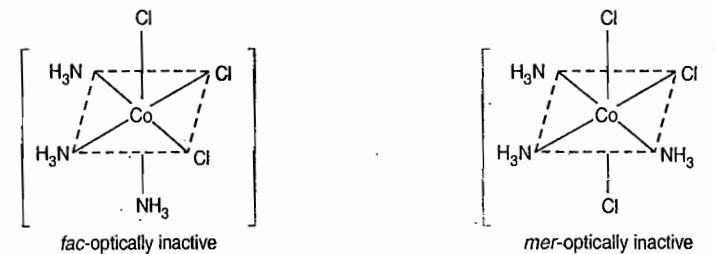

Figure 2.46

(iv) $[Ma_2b_2c_2]^{n\pm}$ type complexes : An important example of this type of complexes is $[Pt(NH_3)_2(py)_2Cl_2]^{2+}$ ion. This complex ion exist in five geometrical isomers, out of these only one isomer exists as two optical isomers which are mirror image of each other and are non-superimposable on each other, as shown in Figure 2.47.

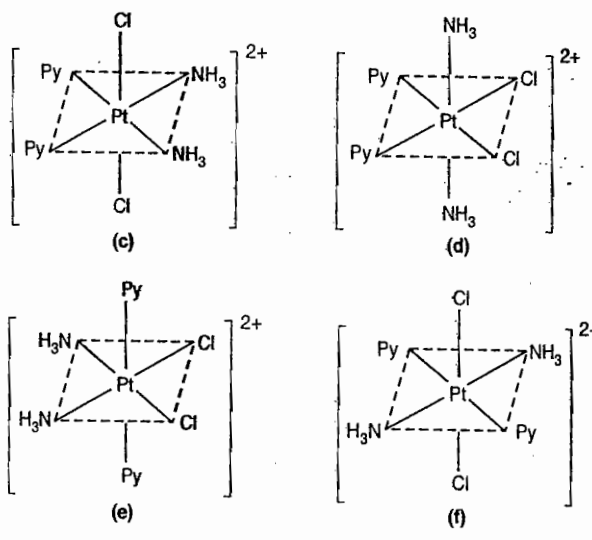
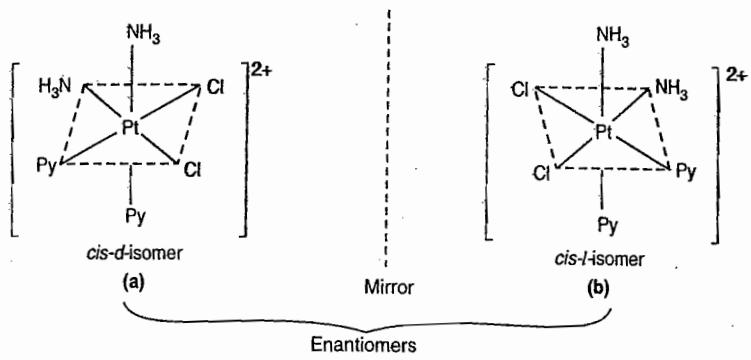

Figure 2.47 Steroisomers (geometrical and optical isomers) of $[Pt(NH_3)_2Cl_2]^{2+}$

Isomers (a) and (b) are the mirror images (*i.e.*, enantiomers) of each other and are optically active. Isomers (c), (d), (e) and (f) are achiral and optically inactive and thus these isomers do not exist as optical isomers.

(v) $[Mabcdef]^{n\pm}$ type Complexes :

$[Pt(py)(NH_3)(NO_2)(Cl)(Br)(I)]^{IV}$ is the only complex of this type. The possible number of geometrical isomers of this complex is 15. Each of these 15 geometrical isomers is chiral and hence is optically active. Therefore, there are 15 pairs of enantiomers (*i.e.*, total number of optical isomers is 30). The optical isomers of one of the 15 geometrical isomers are shown in Figure 2.48.

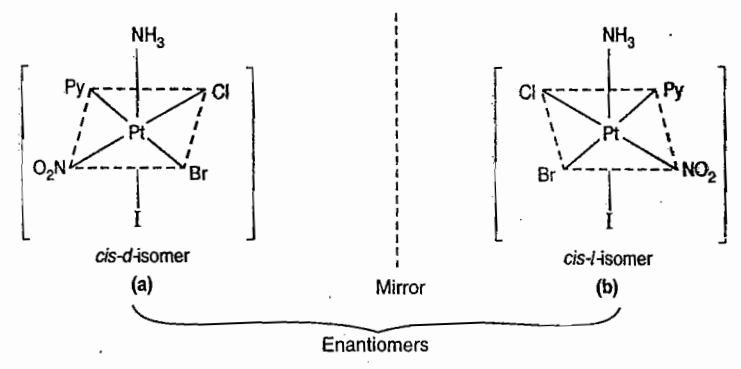

Figure 2.48

(vi) $[M(AA)_3]^{n\pm}$ type Complexes :

Here (AA) is a symmetric bidentate ligand which may be either a neutral or negative ion. The examples of this type of complexes are : $[Co(en)_3]^{3+}$, $[Cr(ox)_3]^{3-}$ etc. each of which is chiral. Such complexes can exist in either of two enantiomeric forms (*i.e.*, *d*- and *l*- isomers) or a racemic mixture of the two. It is to be noted that an octahedral complex containing three chelate rings are always chiral and optically active. Therefore, these complexes are always exist as pairs of enantiomers. Optical isomers of $[Co(en)_3]^{3+}$ and $[Cr(ox)_3]^{3-}$ ions are shown in Figure 2.49.

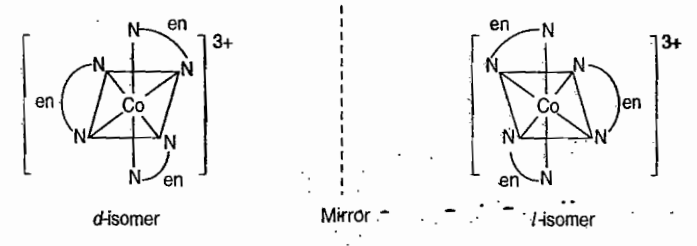

Figure 2.49 (a) Optical isomers of $[Co(en)_3]^{3+}$ ion

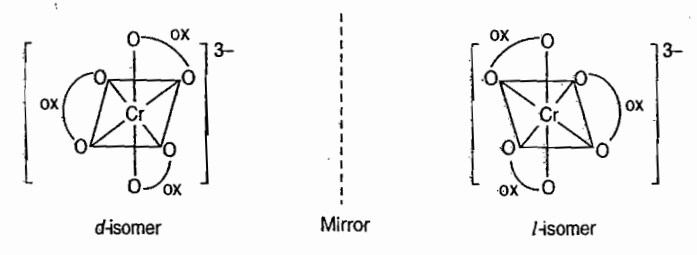

Figure 2.49 (b) Optical isomers of $[Cr(ox)_3]^{3-}$ ion

(vii) $[M(AA)_2a_2]^{n\pm}$ type complexes : An important example of this type of complexes is $[Co(en)_2Cl_2]^+$ ion. This complex ion exists as *cis*- and *trans*- isomers, *cis*- isomers is chiral and optically active. Thus, it exists as *d*- and *l*- isomers as shown in Figure 2.50. On the other hand, the *trans*- isomer is achiral and optically inactive, therefore, this *trans*- isomer does not show optical isomerism.

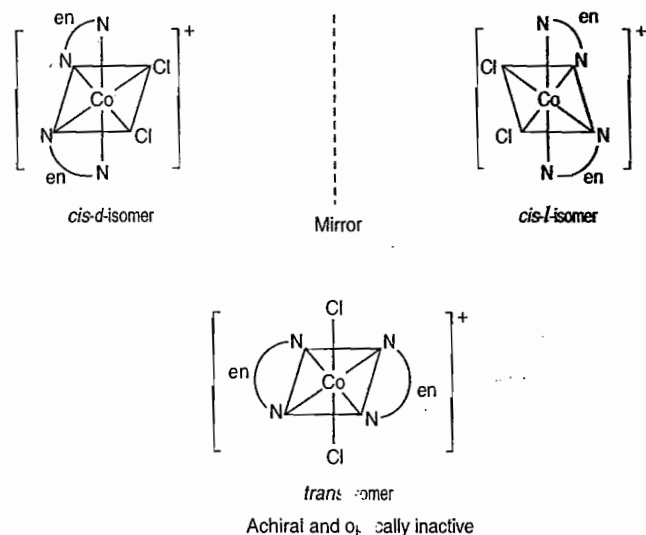

Figure 2.50 Stereoisomers of $[Co(en)_2Cl_2]^+$ ion

Other examples of $[M(AA)_2a_2]^{n\pm}$ type complexes are : $[Co(en)_2(NO_2)_2]^+$, $[Cr(C_2O_4)_2(H_2O)_2]^-$, $[Ir(C_2O_4)_2Cl_2]^{3-}$ etc.

(viii) $[M(AA)_2ab]^{n\pm}$ type Complexes : An important example of this type of complexes is $[Co(en)_2(NH_3)Cl]^{2+}$ ion. This complex ion exists in *cis* and *trans*- forms. *cis*- isomer is chiral and optically active. Therefore, it can be resolved into *d*- and *l*- isomers. The *d*- and *l*- isomers are shown in Figure 2.51. On the other hand, the *trans*- isomer is achiral and optically inactive. Therefore, the *trans*- isomer can not be resolved into *d*- and *l*- isomers.

(ix) $[M(AA)_2b_2]^{n\pm}$ type Complexes : Some examples of this type of complexes are : $[Co(en)(NH_3)_2Cl_2]^+$, $[Co(C_2O_4)(NH_3)_2(NO_2)_2]^+$, $[Co(en)(py)_2(Cl_2)]^+$ etc. These complex ions show geometrical isomerism. The *cis*- isomers are chiral and optically active. Therefore, these *cis*- isomers can be resolved into *d*- and *l*- isomers. The *trans*- isomers are achiral and optically inactive and hence do not show optical isomerism. The optical isomers of $[Co(en)(NH_3)_2Cl_2]^+$ ion are shown in Figure 2.52.

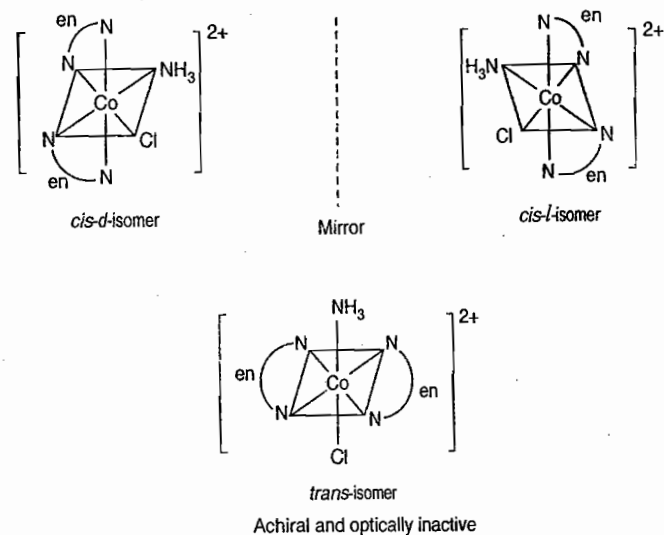

Figure 2.51 Optical isomers of $[Co(en)_2(NH_3)Cl]^{2+}$ ion

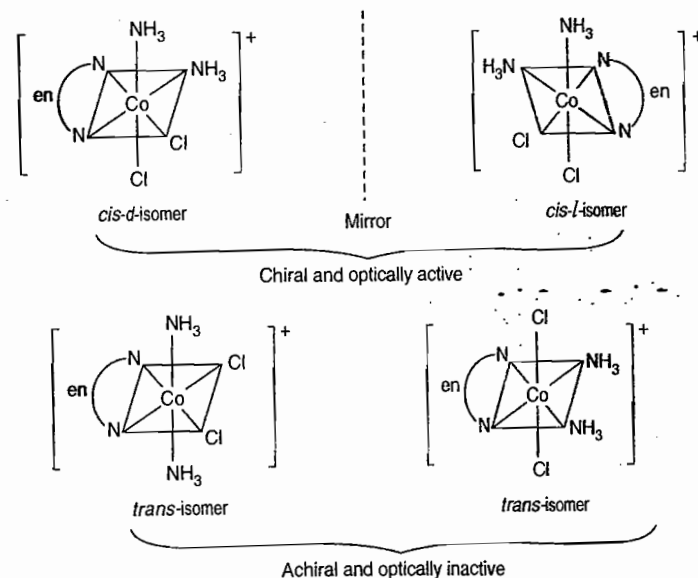

Figure 2.52 Stereoisomers of $[Co(en)(NH_3)_2Cl_2]^+$ ion

(x) $[M(AB)_3]^{n\pm}$ type Complexes : An important example of this type of complexes is $[Co(gly)_3]$. This complex show geometrical isomerism and exist in *fac-* and *mer-* isomeric forms. Both these isomers are chiral and optically active. Therefore, both these isomers (*fac-* and *mer-*) can be resolved into *d-* and *l-* isomers. The optical isomers of $[Co(gly)_3]$ are shown in Figure 2.53.

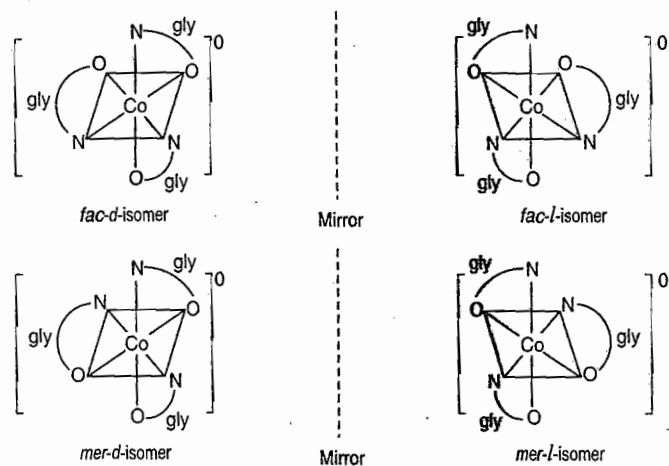

Figure 2.53 Optical isomers of $[Co(gly)_3]$

(xi) $M(AA)_2(BB)$ type Complexes : An important example of this type of complexes is $[Co(en)_2(ox)]^+$ ion. This complex is neither *cis-* nor *trans-* but it has one optical isomer as shown in Figure 2.54.

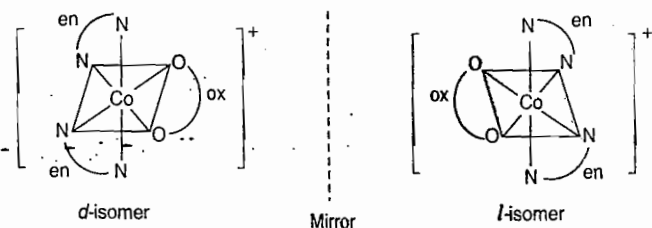

Figure 2.54 Optical isomers of $[Co(en)_2(ox)]^+$ ion.

(xii) $[M(AA)_2(AB)]^{n\pm}$ type Complexes : This type of complexes do not show geometrical isomerism but these are chiral and optically active. Therefore, these complexes can exist in *d-* and *l-* isomeric forms as shown in Figure 2.55.

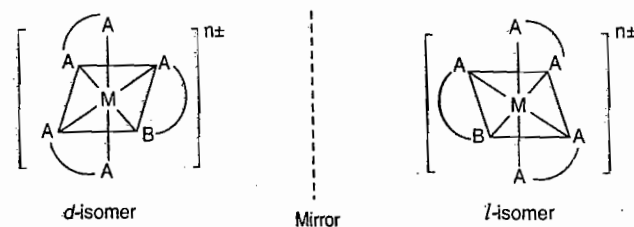

Figure 2.55 Optical isomers of $[M(AA)_2(AB)]^{n\pm}$ where AA is symmetric bidentate ligand and AB is unsymmetric bidentate ligand.

(xiii) $[M(AA)(AB)_2]^{n\pm}$ type Complexes : This type of complexes show geometrical isomerism and all geometrical isomers are chiral and optically active. Therefore, all the geometrical isomers can exist in *d-* and *l-* forms as shown in Figure 2.56.

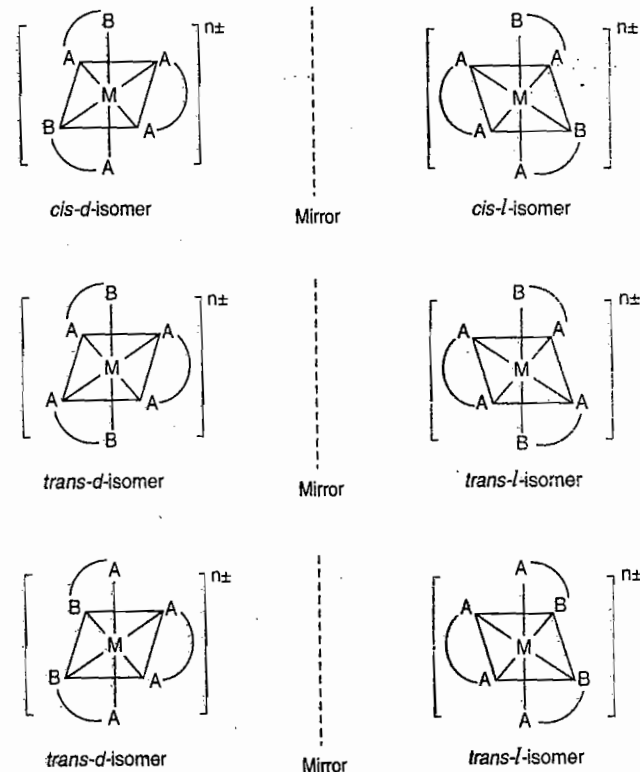
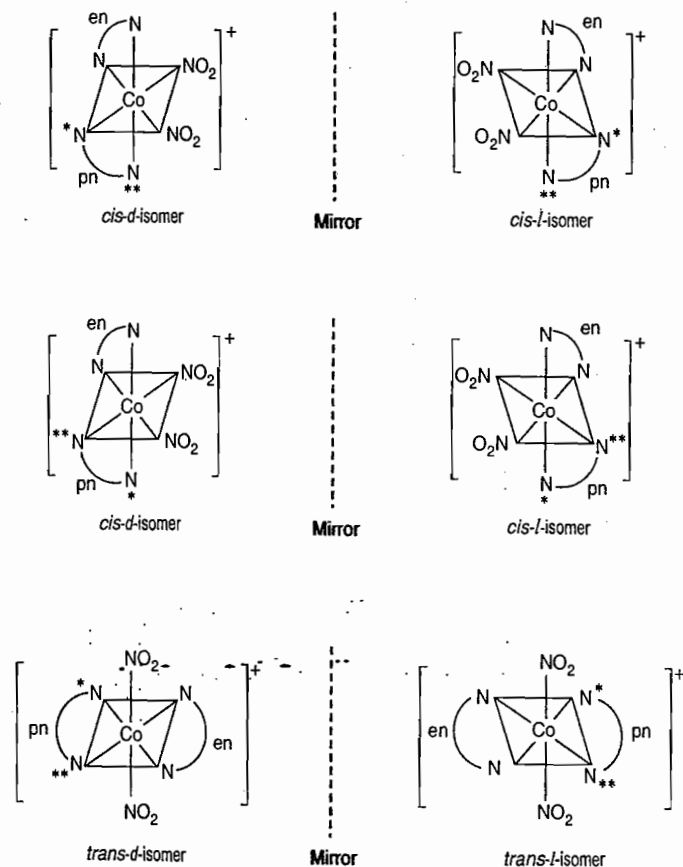

Figure 2.56 Stereoisomers of $[M(AA)(AB)_2]^{n\pm}$ ion.

(xiv) Octahedral Complexes Containing Optically Active Ligands :

An important example of this type of complexes is $[\text{Co}(\text{en})(\text{pn})(\text{NO}_2)_2]^+$ ion. This complex ion exists as two *cis*- and one *trans*- isomers, each of the *cis*- isomers is chiral and optically active. Therefore, the *cis*-isomers exist in *d*- and *l*- isomeric forms (Figure 2.57). On the other hand, the *trans*-isomer has plane of symmetry and therefore, should be achiral and optically inactive but this isomer has optically active ligand (pn). Thus, it would be optically active.

Figure 2.57. Optical isomers of $[\text{Co}(\text{en})(\text{pn})(\text{NO}_2)_2]^+$ ion.

(xv) Octahedral Complexes Containing Polydentate Ligands such as EDTA⁴⁻ : The important examples of this type of complexes are : $[\text{Ca}(\text{EDTA})]^{2-}$, $[\text{Mg}(\text{EDTA})]^{2-}$, $[\text{Co}(\text{EDTA})]^-$ etc. These complexes are neither *cis*- nor *trans*- but these are chiral and optically active. Therefore, they exist as *d*- and *l*-isomers. The *d*- and *l*-isomers of $[\text{Co}(\text{EDTA})]^-$ are shown in Figure 2.58.

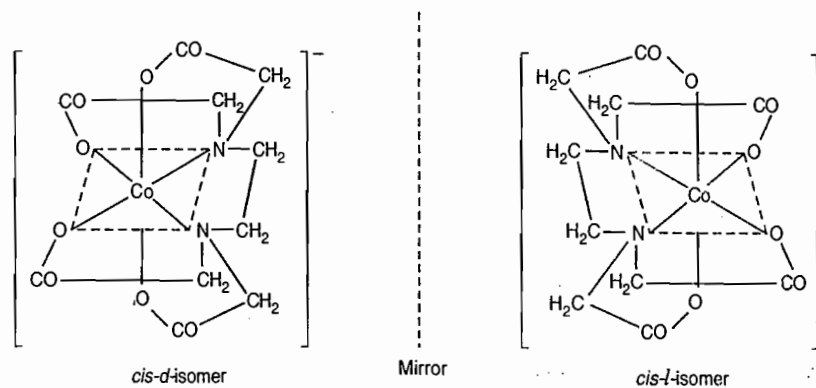
Figure 2.58. Optical isomers of $[\text{Co}(\text{EDTA})]^-$ ion.

(xvi) Bridged Binuclear Octahedral Complexes (i.e., Polynuclear Complexes) : Optical isomerism is not limited to mononuclear complexes. Polynuclear complexes containing bridging ligands can also exist as *d*- and *l*- isomers. For example, the binuclear Co^{3+} complex ion shown in Figure 2.59. exist as *cis*- and *trans*- isomers. The *cis*-isomers is chiral and optically active and thus exists as *d*- and *l*- isomers as shown in Figure 2.60. The *trans*- isomer is achiral and inactive and thus this isomer is an internally optically compensated i.e., it is *meso* form.

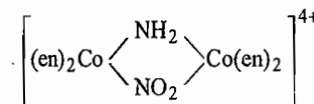
Figure 2.59. Structure of $[(\text{en})_2(\text{NH}_2)_2(\text{NO}_2)]^{4+}$ ion.

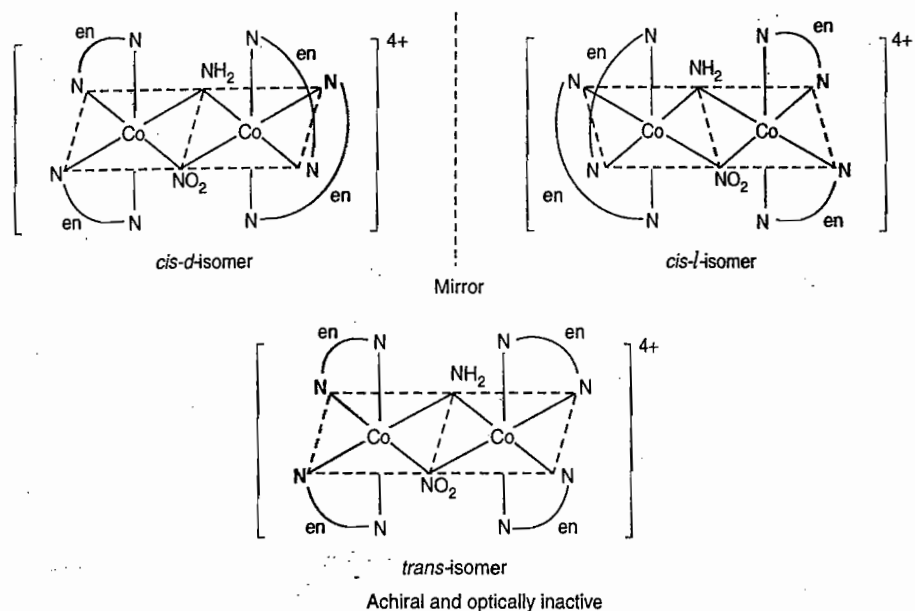
Figure 2.11 Stereoisomers of $[\text{Co}(\text{en})_2(\text{NH}_3)(\text{NO}_2)]^{2+}$ **Fill in the Blanks**

- The NO_2^- ligand can form isomers.
- The complex $\text{cis-}[\text{Co}(\text{en})_2(\text{NH}_3)\text{Cl}]^{2+}$ can exist as
- The complex $[\text{Co}(\text{NH}_3)_4\text{Cl}_2]^+$ can exist as isomers.
- The complex $[\text{Co}(\text{NH}_3)_4\text{Cl}(\text{NO}_2)]\text{Br}$ can exist as structural isomers as and isomers.
- The complex $[\text{Co}(\text{EDTA})]^-$ is a
- $\text{cis-}[\text{Co}(\text{en})_2\text{Cl}_2]^+$ is optically
- Chirality is the essential condition for
- The complex $[\text{Co}(\text{NH}_3)_3(\text{NO}_2)_3]$ show two geometrical isomers namely and

- [Ans. 1. linkage
3. geometrical
5. chelate
7. optical activity

2. enantiomers
4. linkage, ionization
6. active
8. *facial, meridonal*]

Objective Questions

- Number of stereoisomers of the compound $[\text{Co}(\text{NH}_3)_3\text{Cl}_2\text{Br}]$ are :
(a) 1 (b) 2
(c) 3 (d) 4
- The complexes $[\text{Co}(\text{1,2-diaminopropane})_2\text{Cl}_2]^+$ and $[\text{Co}(\text{1,3-diaminopropane})_2\text{Cl}_2]^+$ represent an example of :
(a) ligand isomerism (b) linkage isomerism
(c) ionization isomerism (d) coordination isomerism
- The number of possible isomers for the octahedral complex ion $[\text{Co}(\text{en})\text{Cl}_2\text{Br}_2]^-$ is:
(a) 2 (b) 4
(c) 6 (d) 8
- For a complex, MX_3Y_3 possessing trigonal prismatic geometry, the number of possible isomers is:
(a) 2 (b) 4
(c) 3 (d) 6
- The number of possible geometrical isomers for octahedral $\text{Co}(\text{ox})(\text{PMe}_3)_2\text{NH}_3\text{Cl}$ is :
(a) 2 (b) 3
(c) 4 (d) 5

C)6 - geometrical

6. The existence of two different coloured complexes of $\text{Co}(\text{NH}_3)_4\text{Cl}_2$ is due to :
 (a) optical isomerism (b) linkage isomerism
 (c) geometrical isomerism ✓ (d) coordination isomerism
7. The isomerisms that are possible in the Co(III) complexes $[\text{Co}(\text{NH}_3)_3(\text{NO}_2)_3]$ and $[\text{Co}(\text{NH}_3)_5\text{NO}_2]\text{Cl}_2$, respectively, are :
 (a) coordination and position (b) optical and linkage
 (c) geometrical and linkage ✓ (d) optical and optical
8. The complexes $[\text{Co}(\text{NH}_3)_4(\text{H}_2\text{O})\text{Cl}]\text{Br}_2$ and $[\text{Co}(\text{NH}_3)_4\text{Br}_2]\text{Cl}\cdot\text{H}_2\text{O}$ are examples of :
 (a) ionization isomerism (b) linkage isomerism
 (c) geometric isomerism (d) optical isomerism
9. The pair of ions that most commonly forms complexes with coordination number 2 is :
 (a) Cd (II) and Hg(II) (b) Cu (II) and Hg (I)
 (c) Cd (II) and Hg (I) (d) Cu (I) Hg (II) ✓
10. The octahedral complex/complex ion which shows both *facial* and *meridional* isomers is :
 (a) triglycinatocobalt(III) (b) tris (ethylenediamine cobalt(III))
 (c) dichlorodiglycinatocobalt(III) (d) trioxalatocobaltate(III)
11. Which one of the following compounds has optical isomers ?
 (a) $\text{trans}-[\text{Co}(\text{en})_2\text{Cl}_2]^+$ (en = ethylenediamine)
 (b) $[\text{PtCl}_2(\text{NH}_3)_2]$
 (c) $[\text{Co}(\text{en})_3]^{3+}$
 (d) $[\text{Fe}(\eta^5-\text{C}_5\text{H}_5)_2]$
12. The complex $[\text{PtCl}(\text{NCS})(\text{NH}_3)_2]$ is capable of exhibiting :
 (a) ionization isomerism (b) linkage isomerism
 (c) coordination isomerism (d) optical isomerism
13. The complexes $[\text{Cu}(\text{NH}_3)_4]$, $[\text{PtCl}_4]$ and $[\text{Pt}(\text{NH}_3)_4][\text{CuCl}_4]$ are an example of :
 (a) ionization isomerism (b) linkage isomerism
 (c) coordination isomerism (d) geometric isomeric
14. A complex of Ni(II), $[\text{NiCl}_2(\text{PPh}_3)_2]$ is paramagnetic. The analogous Pd(II) complex is diamagnetic. The number of isomers that will exist for the nickel and the palladium complexes are :
 (a) one, one (b) one, two
 (c) two, one (d) two, two
15. The number of isomers that exists for $[\text{Mo}(\text{C}_5\text{H}_5\text{N})_3(\text{CO})_3]$ is :
 (a) one (b) two ✓
 (c) three (d) four
16. The complex $[\text{Co}(\text{NH}_3)_5(\text{NO}_2)]^{2+}$ is capable of exhibiting :
 (a) optical isomerism (b) geometrical isomerism
 (c) ionization isomerism (d) linkage isomerism

17. The complex that exists as a pair of enantiomers is :
 (a) $\text{trans}-[\text{Co}(\text{H}_2\text{NCH}_2\text{CH}_2\text{NH}_2)_2\text{Cl}_2]^+$
 (b) $\text{cis}-[\text{Co}(\text{NH}_3)_4\text{Cl}_2]^+$
 (c) $[\text{Pt}(\text{PPh}_3)(\text{Cl})(\text{Br})(\text{CH}_3)]^-$
 (d) $[\text{Co}(\text{H}_2\text{NCH}_2\text{CH}_2\text{NH}_2)_3]^{3+}$
18. The number of possible isomers for $[\text{Ru}(\text{bpy})_2\text{Cl}_2]$ is (bpy = 2, 2'-bipyridine) :
 (a) 2 (b) 3 ✓
 (c) 4 (d) 5
19. The number of possible isomers for the square planar mononuclear complex $[(\text{NH}_3)_2\text{M}(\text{CN})_2]$ of a metal M is :
 (a) 2 (b) 4
 (c) 6 (d) 3
20. Green coloured $\text{Ni}(\text{PPh}_2\text{Et})_2\text{Br}_2$, has a magnetic moment of 3.20 B.M. The geometry and the number of isomers possible for the complex respectively, are :
 (a) square planar and one (b) tetrahedral and one
 (c) square planar and two (d) tetrahedral and two
21. The total number of stereoisomers of $[\text{CoCl}_3(\text{NO}_2)_3]^{2-}$ ion are:
 (a) 2 ✓ (b) 3
 (c) 4 (d) 6
22. Among the following complexes :
 (i) $[\text{Ru}(\text{bipyridyl})_3]^+$
 (ii) $[\text{Cr}(\text{EDTA})]^-$
 (iii) $\text{trans}-[\text{CrCl}_2(\text{oxalate})_2]^{3-}$
 (iv) $\text{cis}-[\text{CrCl}_2(\text{oxalate})_2]^{3-}$
 the chiral complexes are :
 (a) (i), (ii), (iv) (b) (ii), (iii), (iv)
 (c) (i), (ii), (iii) (d) (i), (iii), (iv)

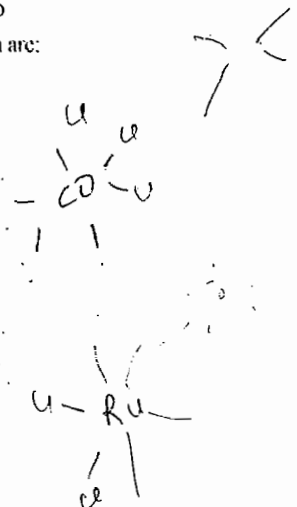

AB₃C₃ 2

ANSWERS

- | | | | | | | |
|---------|---------|---------|---------|---------|---------|---------|
| 1. (c) | 2. (a) | 3. (b) | 4. (c) | 5. (c) | 6. (c) | 7. (c) |
| 8. (a) | 9. (d) | 10. (a) | 11. (c) | 12. (b) | 13. (c) | 14. (b) |
| 15. (b) | 16. (d) | 17. (d) | 18. (b) | 19. (a) | 20. (b) | 21. (a) |
| 22. (a) | | | | | | |

Subjective Questions

- $[\text{NiBr}_2(\text{PEtPh}_2)_2]$ has been isolated in green and brown species. Identify the two species.
- Give one example of each of the following :
 - Ionization isomerism
 - Hydrate isomerism
 - Linkage isomerism
 - Coordination isomerism
 - Coordination position isomerism
 - Ligand isomerism
- Sketch all possible isomers of $[\text{Co}(\text{NH}_3)_2(\text{NH}_2)_2(\text{C}_2\text{O}_4)]^-$ ion. Label the isomers according to the type of isomerism.
- A compound $[\text{Co}(\text{en})_2(\text{NO}_2)_2]\text{Cl}$ exists in three isomeric forms (A), (B) and (C). (A) reacts neither with AgNO_3 nor with en and is optically inactive. (B) reacts with AgNO_3 and forms white precipitate but not reacts with en and is optically inactive. (C) is optically active and reacts with both AgNO_3 and en. Identify each isomer, draw their structures and give suitable reasons for your answers.
- Symmetrical di- μ -hydroxotetrakis(ethylenediamine)dichlorat(III) chloride (A) reacts with aq. HCl to give a product $\text{Co}(\text{en})_2\text{Cl}_3$ (B) which is resolvable with optical isomers. When it is kept in acidic solution, the compound changes colour and gives an isomer (C) which is not resolvable. Give structure of A, B and C and also write the optical isomers of B.
- Is it possible to separate the optical isomers of a neutral complex by forming diastereomers?
- Describe the type of isomers associated with carbonatoaquatetraamminecobalt(III) chloride monohydrate.
- A 4 coordinated complex $[\text{MA}_2\text{B}_2]$ exists in two isomeric forms I and II. I has a dipole moment of 6.0 D units and II 20.1 D. Draw the structures of I and II.
- Indicate the type of isomerism exhibited by the following pairs of isomers and suggest one test for each set to distinguish them.
 - $[\text{Cr}(\text{NH}_3)_6][\text{Co}(\text{NO}_2)_6]$ and $[\text{Co}(\text{NH}_3)_6][\text{Cr}(\text{NO}_2)_6]$
 - $[\text{Co}(\text{H}_2\text{O})_5\text{Cl}]\text{Cl}_2 \cdot \text{H}_2\text{O}$ and $[\text{Co}(\text{H}_2\text{O})_4\text{Cl}_2]\text{Cl} \cdot 2\text{H}_2\text{O}$
- What type of isomers are shown by $[\text{Co}(\text{NH}_3)_5(\text{NO}_2)]\text{Cl}$ and draw their structures?
- Draw all the possible geometrical and optical isomers for the following complexes :
 - $[\text{Co}(\text{NH}_3)_3\text{Cl}_3]$
 - $[\text{Co}(\text{NH}_3)_2(\text{Py})_2\text{Cl}_2]^+$
 - $[\text{Co}(\text{dien})(\text{NO}_2)_3]$
 - $[\text{Co}(\text{dien})_2]^{3+}$
 - $[\text{Pt}(\text{en})_2\text{ClBr}]^{2+}$
 - $[\text{Co}(\text{en})_3]^{3+}$
- For the $[\text{Co}(\text{en})_2(\text{NO}_2)(\text{SCN})]^+$ ion :
 - Draw all the possible structural isomers.
 - Draw all the possible stereoisomers.
 - Estimate the total number of isomers (structural + stereoisomers).



3

IUPAC Nomenclature of Coordination Compound

The rules recommended by the International Union of Pure and Applied Chemistry (IUPAC) for naming of coordination compounds are as follows :

- If a coordination compound is ionic (*i.e.*, the coordination compound contains either a complex cation or complex anion or both), the cation is named first followed by the anion and the cation is separated by a space from the anion, just as in other simple salts. No space is used within the name of the complex ion. For example, in $\text{K}_4[\text{Fe}(\text{CN})_6]$ and $[\text{Co}(\text{NH}_3)_6]\text{Cl}_3$ the cations K^+ and $[\text{Co}(\text{NH}_3)_6]^{3+}$ are named first followed by the names of anions $[\text{Fe}(\text{CN})_6]^{4-}$ and Cl^- respectively.
- If a coordination compound is neutral, the name of compound is written as one word (*i.e.*, the name of neutral complex compound is given without space).
- In the name of a complex ion or non-ionic complex, the ligands are named first but in alphabetical order before the name of the metal ion or atom. The numeral prefixes such as di, tri, tetra etc. which indicate the number of ligands of a particular type are ignored in determining the order.
- Oxidation number of metal cation or atom is written in Roman numeral in parentheses immediately following the name of the metal. There is no space between the name of metal and parentheses.
- If the complex ion or neutral complex contains more than one ligand of a particular kind, the Greek prefixes di, tri, tetra, penta, hexa- and so forth are used for 2, 3, 4, 5, 6 and so forth respectively.
- If the name of the ligand itself contains a Greek prefix, its name is put in parentheses and the prefixes *bis*, *tris*, *tetrakis*, *pentakis*, *hexakis*, *heptakis* are used for 2, 3, 4, 5, 6 and 7 respectively to specify the number of ligands. For example, the ligand ethylenediamine already contains di, therefore, if two or three such ligands are present in a complex, the name is *bis* (ethylenediamine) or *tris* (ethylenediamine).
- The prefixes *bis*, *tris*, *tetrakis* and so forth are also used for complex ligands. For example, if two CH_3NH_2 ligands are present in a complex, the prefix *bis*- is used. Thus the name of the ligand is *bis* (methylamine). If we name it as dimethylamine, we are referring to the following compound :

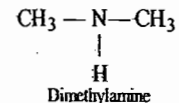

8. The names of anionic ligands end with the letter o. They are usually obtained by changing anion endings -ide to -o, -ite to -ito and -ate to -ato. But according to latest IUPAC convention, all the anionic ligands names are obtained by replacing the last letter e by o.

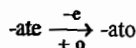
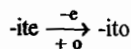
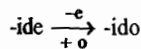

The names of anionic ligands are given in Table 1.1.

In case of ambidentate ligands, the atom which is bonded to the metal cation is specified by placing the symbol of the bonded atom after the name of the ligand separated by hyphen. These ligands are also given specific names for each mode of attachment. Some examples are given below :

Name and Mode of Attachment of Ambidentate Ligands

Ambidentate Ligands	Name and Mode of Attachment
NO_2^-	- NO_2^- , nitrito - N or nitro
SCN^-	- ONO^- , nitrito - O or nitrito - SCN^- , thicyanato - S or thicyanato - NCS^- , thicyanato - N or isothiocyanato

Neutral ligands are given the same name as the parent molecule, though there are exceptionally some ligands which are given special names.

Neutral ligands having usual names :

Neutral Ligands	Names
N_2	dinitrogen
O_2	dioxygen
$\text{C}_5\text{H}_5\text{N}$	pyridine
bpy	bipyridyl
CH_3NH_2	methylamine
$(\text{CH}_3)_2\text{NH}$	dimethylamine
NH_2-NH_2	hydrazine
NH_2OH	hydroxylamine

NH_2CONH_2	urea
NH_2CSNH_2	thiourea
$(\text{CH}_3)_2\text{SO}$, DMSO	dimethylsulphoxide
CH_3CN	acetonitrile or methylcyanide
PPh_3	triphenylphosphine
PCl_3	trichlorophosphine

Ligands having special names :

Neutral Ligands	Name
NH_3	ammine
CO	carbonyl
CS	thiocarbonyl
H_2O	aqua
NO	nitrosyl

9. The vowel ending the numeral prefix of the ligands will not be ignored while writing the name. For example, if there are four NH_3 , and two oxide ligands, then these are named as tetraammine and trioxide respectively. Mono is an exception, mono + oxide \rightarrow monoxide.
10. For a complex cation or neutral complex, the usual name of the metal is used. If the complex is an anion, the ending -ate either adds to the name of metal or replaces -ium, -en or -ese ending.

Name of metals obtained by replacing ending -ium by -ate.

Metal	Anion Name
aluminium	aluminate
scandium	scandate
titanium	titanate
vanadium	vanadate
chromium	chromate
zirconium	zirconate
palladium	palladate
rhodium	rhodate
rhenium	rhenate

Name of metals in complex anion obtained by addition of ending- ate.

Metal	Anion Name
manganese	manganate
cobalt	cobaltate
nickel	nickelate
zinc	zincate
platinum	platinate
tungsten	tungstate
molybdenum	molybdate

Name of metals originated from Latin name :

Metal	Anion Name
iron	ferrate
copper	cuprate
silver	argentate
lead	plumbate
gold	aurate
tin	stannate

The rules given above are illustrated by the following examples :

(a) Non-ionic or Neutral Complexes :

$[\text{Co}(\text{NH}_3)_3\text{Cl}_3]$	triamminetrichlorocobalt(III)
$[\text{Co}(\text{NH}_3)_3(\text{NO}_2)_3]$	triamminetrinitrocobalt(III)
	OR
	triamminetrinitrito - N cobalt(III)
$[\text{Rh}(\text{NH}_3)_3(\text{NCS})_3]$	triamminetriisothiocyanatorhodium(III)
	OR
	triamminetrithiocyanato - N rhodium(III)
$[\text{Ni}(\text{CO})_4]$	tetracarbonylnickel (0)
$\text{Fe}(\text{C}_5\text{H}_5)_2$	bis (cyclopentadienyl) iron(II)
$[\text{Cu}(\text{CH}_3\text{NH}_2)_2\text{Cl}_2]$	dichloro bis (methylamine) copper(II)
$[\text{Cr}(\text{C}_6\text{H}_6)_2]$	bis (benzene) chromium(0)
$[\text{CuCl}_2(\text{O}=\text{C}(\text{NH}_2)_2)_2]$	dichloro bis (urea) copper(II)

(b) Complexes Containing Complex Cations

$[\text{Co}(\text{NH}_3)_6]\text{Cl}_3$	hexaamminecobalt(III) chloride
$[\text{Co}(\text{NH}_3)_5\text{Cl}]\text{Cl}_2$	pentaamminechlorocobalt(III) chloride
$[\text{Co}(\text{NH}_3)_4(\text{H}_2\text{O})_2]\text{Cl}_3$	tetraamminediaquacobalt(III) chloride
$[\text{Fe}(\text{CNCH}_3)_6]\text{Cl}_2$	hexakis (methylisocyanide) iron(II) chloride
$[\text{Co}(\text{en})_3]\text{Cl}_3$	tris (ethylenediamine)cobalt(III) chloride

$[\text{Co}(\text{NH}_3)_4(\text{NO}_2)\text{Cl}]\text{Cl}$	tetraamminechloronitrocobalt (III) chloride
	OR
	tetraamminechloridonitrito-N cobalt (III) chloride
$[\text{Pt}(\text{NH}_3)_2(\text{NH}_2\text{CH}_3)\text{Cl}]\text{Cl}$	diamminechloromethylamine platinum (II) chloride
$[\text{Ru}(\text{NH}_3)_5(\text{N}_2)]\text{Cl}_2$	pentaamminedinitrogenruthenium (II) chloride
$[\text{Co}(\text{NH}_3)_5(\text{SO}_4)]\text{Cl}$	pentaamminesulphatocobalt (III) chloride
$[\text{Co}(\text{NH}_3)_5\text{Cl}]\text{SO}_4$	pentaamminechlorocobalt (III) sulphate
$[\text{Co}(\text{NH}_3)_5(\text{ONO})]\text{SO}_4$	pentaamminenitrito - O cobalt (III) sulphate
$[\text{Fe}(\text{H}_2\text{O})_5(\text{NO})]\text{SO}_4$	pentaquaquanyrosyliron (I) sulphate
	Magnetic moment measurements show that in complexes of iron, NO is present in + 1 oxidation state. Therefore oxidation state of Fe in $[\text{Fe}(\text{H}_2\text{O})_5(\text{NO})]^{2+}$ is + 1.

Coordination Compounds Containing Complex Anion

$\text{Na}_2[\text{Fe}(\text{CN})_5(\text{NO})]$ sodium pentacyanonitrosylferrate (II). As discussed earlier that in complexes of iron, NO exists in + 1 oxidation state. Oxidation state of iron in $\text{Na}_2[\text{Fe}(\text{CN})_5(\text{NO})]$ is + 2 as calculated below. Let the oxidation number of Fe is x. Then

$$+1 \times 2 + x + (-1 \times 5) + 1 = 0$$

$$\therefore x = +2$$

$\text{Na}_2[\text{Ni}(\text{en})(\text{SO}_4)\text{Br}_2\text{H}_2\text{O}]$	sodiumaquadibromo ethylene diamine sulphatonicobalt(II)
$\text{K}_2[\text{Co}(\text{N}_3)_4]$	potassium tetraazidocobaltate(II)
$\text{Ca}[\text{PCl}_6]_2$	calcium hexachlorophosphate(V)
$\text{Fe}_4[\text{Fe}(\text{CN})_6]_3$	iron hexacyanoferrate(II)
$[(\text{CH}_3)_4\text{N}]_2[\text{V}(\text{O})\text{Cl}_4]$	tetramethylammonium tetrachlorooxovanadate(IV)
$\text{Na}[\text{PtBrCl}(\text{NO}_2)(\text{NH}_3)]$	sodium amminebromochloronitrito-N platinate(II)
$\text{K}[\text{Co}(\text{EDTA})]$	potassium ethylenediaminetetraacetato cobaltate(III)
$\text{K}_2[\text{Cr}(\text{CN})_2(\text{O})_2(\text{O}_2)(\text{NH}_3)]$	potassium amminedicyanodixoperoxo chromate(VI)
$\text{K}_2[\text{O}_5\text{NCl}_5]$	potassium pentachloronitridoosmate(VI)
$[\text{Ph}_4\text{As}][\text{PtCl}_2(\text{H})(\text{CH}_3)]$	tetraphenylarsonium dichlorohydrimethylplatinate(II)

Naming of Bridged Polynuclear Complexes

A ligand that bridges two metal cations or atoms is denoted by prefix μ - added to the name of the bridging ligands. For example :

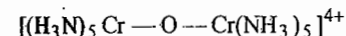

μ -oxo bis [pentaammine chromium (III)]

OR pentaammine chromium (III) - μ -oxopentaammine chromium (III)

OR μ -oxodecaammine dicobalt (III) ion

If a complex has two, three or four bridging ligands of same kind then the prefix di- μ -, tri- μ tetra- μ are used respectively. For example :

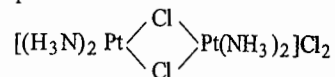

di- μ chloro bis [diammine platinum (II)] Chloride
OR diammine platinum (II) - di- μ - chloro diammine platinum (II) chloride

If a complex has two or more different kind of ligands, then prefix μ - is used for each kind of bridging ligand. The name of bridging ligands are written in the alphabetical order. For example :

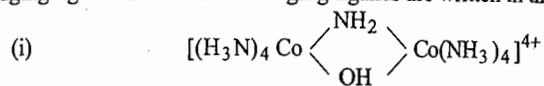

μ - amido - μ - hydroxo bis [tetraamminecobalt (III)]
OR tetraammine cobalt (III) - μ - amido - μ - hydroxotetraammine cobalt (III)
OR μ - amido - μ - hydroxo octaamminedicobalt (III).

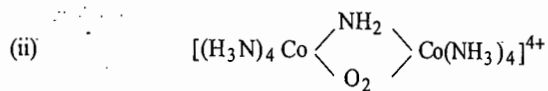

μ - amido - μ - superoxo bis [tetraamminecobalt (III)]
OR μ - amido - μ - superoxooctaamminedicobalt (III).
OR tetraammine cobalt (III) - μ - amido - μ - superoxotetraammine cobalt (III)

For this complex ion, magnetic moment measurements show that the bridging $-\text{O}_2-$ ligand acts as superoxide (O_2^-) ion.

If the bridging and the terminal (non-bridging) ligands both are of same kind, then the bridging ligands are named first. For example :

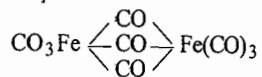

tri - μ - carbonyl bis [tricarbonyliron(0)]
or
tri - μ - carbonyl hexacarbonyldiiron(0)

If a bridging ligand bridges more than two metal centres, prefix μ_3 -, μ_4 - etc is used to indicate the number of metal centres bridged with a given ligand. For example, in basic beryllium acetate, $[\text{Be}_4\text{O}(\text{CH}_3\text{COO})_6]$, O^{2-} ligand bridges four Be atoms. Therefore, the name of this compound is:

μ_4 - oxo hexa - μ -acetato tetraberyllium (II)

The structure of basic beryllium acetate is shown in Figure 3.1.

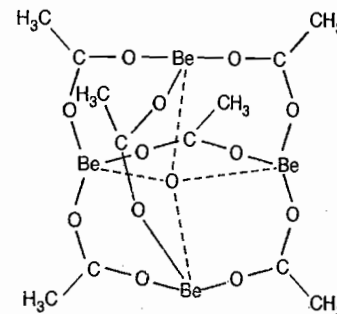

Figure 3.1: Structure of basic beryllium acetate $[\text{Be}_4\text{O}(\text{CH}_3\text{COO})_6]$.

Some other examples of bridged polynuclear complexes are shown below :

(i) $[(\text{H}_3\text{N})_5 \text{Co} - \text{NH}_2 - \text{Co}(\text{NH}_3)_4(\text{H}_2\text{O})] \text{Cl}_5$
pentaammine cobalt(III) - μ - amido tetraammine aquacobalt(III) chloride

(ii) $[(\text{NH}_3)_4 \text{Co} \begin{array}{c} \diagup \text{NH}_2 \\ \diagdown \text{NO}_2 \end{array} \text{Co}(\text{NH}_3)_4]^{4+}$
 μ - amido - μ - nitro bis [tetraammine cobalt(III)]
OR μ - amido - μ - nitro octaamminedicobalt(III)
OR tetraammine cobalt (III) - μ -amido- μ -nitro tetraammine cobalt(III)

(iii) $[\text{Cl}(\text{H}_3\text{N})_3 \text{Co} \begin{array}{c} \diagup \text{NH}_2 \\ \diagdown \text{O}_2 \end{array} \text{Co}(\text{NH}_3)_3 \text{Cl}]^{2+}$
 μ - amido - μ - superoxo bis [triamminechlorocobalt(III)]

(iv) $[(\text{H}_3\text{N})_4 \text{Co} \begin{array}{c} \diagup \text{NH}_2 \\ \diagdown \text{O}_2 \end{array} \text{Co}(\text{NH}_3)_2 \text{Cl}_2]^{2+}$
tetraammine cobalt(III)- μ - amido - μ - superoxo diamminedichloro cobalt(III)

Note : A symmetric bridged dinuclear complex, can be named by any three methods as shown earlier in examples (i), (ii) and (iii) but an unsymmetric complex can be named by only one method as given in example (iv).

(v) $[(\text{SnCl}_3)_2 \text{Rh} \begin{array}{c} \diagup \text{Cl} \\ \diagdown \text{Cl} \end{array} \text{Rh}(\text{SnCl}_3)_2]^{4-}$
di- μ -chloro bis [trichlorostanyl rhodate(I)]

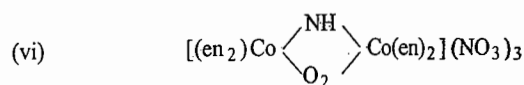

μ - imido - μ - superoxo *tetakis*(ethylenediamine) dicobalt(III) nitrate

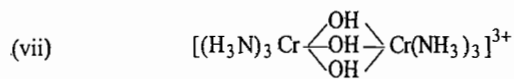

tri - μ - hydroxo *bis*[triammine chromium(III)]

or tri - μ - hydroxohexaammine dicobalt (III)

Naming of Coordination Compounds having Cation and Anion both as Complex Ions

If an ionic complex compound contains both the cation and anion as complex ions, the metal cation in complex cation has its usual name but in complex anion, the metal name ends in -ate. Though, it is difficult to calculate the oxidation states of two metals into two complex ions yet, for calculation of oxidation number of metals, the hit and trial method is used. For this it is to be known the common oxidation states of the two relevant metals.

The hit and trial method of calculation of oxidation states is illustrated by considering some examples as given below :

Example 1 : $[Pt(NH_3)_4][PtCl_4]$

In complex of platinum, the common (or stable) oxidation states are +2 and +4. Thus the positive and negative charges on complex cation and complex anion should satisfy one of these two oxidation states or both.

To decide whether Pt in both the complex ion has +2 or +4 or +2 in one complex ion and +4 in the other, we calculate the oxidation states of Pt in both complex ions by considering the following points :

(i) If we consider -1 charge on anion, then charge on the cation will be +1. Thus, oxidation state of Pt in complex cation and complex anion can be calculated as :

Complex cation	Complex anion
$[Pt(NH_3)_4]^+$	$[PtCl_4]^-$
$x + 0 = +1$	$x - 4 = -1$
$x = +1$	$x = +3$

Thus, oxidation states of Pt are +1 and +3 which are not shown by platinum. Therefore, it is wrong.

(ii) If we consider -2 charge on complex anion, then charge on complex cation will be +2. Thus oxidation states of Pt in the two ions can be calculated as :

Complex cation	Complex anion
$[Pt(NH_3)_4]^{2+}$	$[PtCl_4]^{2-}$
$x + 0 = +2$	$x - 4 = -2$
$x = +2$	$x = +2$

Thus, oxidation state of Pt in both the complex ions is +2 which is a stable oxidation state.
(iii) If we consider -3 charge on anion, then charge on complex cation will be +3.

Complex cation	Complex anion
$[Pt(NH_3)_4]^{3+}$	$[PtCl_4]^{3-}$
$x + 0 = +3$	$x - 4 = -3$
$x = +3$	$x = +1$

Therefore, oxidation state of Pt are +1 and +3.

(iv) Now in the last, if we consider, -4 charge on complex anion, then charge on cation will be +4. Therefore oxidation states of Pt in complex cation and complex anion will be +4 and 0 respectively.

Complex cation	Complex anion
$[Pt(NH_3)_4]^{4+}$	$[PtCl_4]^{4-}$
$x + 0 = +4$	$x - 4 = -4$
$x = +4$	$x = 0$

The oxidation states calculated in points number (i), (iii) and (iv) are not the common oxidation states of Pt. The oxidation state calculated in point number (ii) is +2 in both the complex ions which is the one of the two common oxidation states and it satisfies the charges on the complex cation and anion. Therefore, the name of the complex is :

tetraammineplatinum(II) tetrachloroplatinate(II)

Example 2 : $[Pt(NH_3)_4Cl_2][PtCl_4]$

Oxidation states of Pt in both the complex ions can be calculated as discussed earlier :

	Complex cation	Complex anion
(i)	$[Pt(NH_3)_4Cl_2]^+$	$[PtCl_4]^-$
	$x + 0 - 2 = +1$	$x - 4 = -1$
	$x = +3$	$x = +3$
(ii)	$[Pt(NH_3)_4Cl_2]^{2+}$	$[PtCl_4]^{2-}$
	$x + 0 - 2 = +2$	$x - 4 = -2$
	$x = +4$	$x = +2$
(iii)	$[Pt(NH_3)_4Cl_2]^{3+}$	$[PtCl_4]^{3-}$
	$x + 0 - 2 = +3$	$x - 4 = -3$
	$x = +5$	$x = +1$

(iv)	$[\text{Pt}(\text{NH}_3)_4\text{Cl}_2]^{4+}$	$[\text{PtCl}_4]^{4-}$
	$x + 0 - 2 = +4$	$x - 4 = -4$
	$x = +6$	$x = 0$

The oxidation states calculated in point number (i), (iii) and (iv) are not the common oxidation states of Pt.

The oxidation states of Pt calculated in point number (ii) are +4 and +2 in complex cation and anion respectively which are the common oxidation states of Pt. Therefore the name of the complex is :

tetraamminedichloroplatinum(IV) tetrachloroplatinate(II)

An another method to decide the oxidation states of Pt in complex ions :

Pt in oxidation state of +2 always form complexes or complex ions of coordination number 4 and Pt in oxidation state of +4 always forms complexes of coordination number of 6. For example :

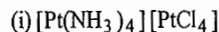

In this complex compound, coordination number of Pt in both the complex cation and complex anion is 4. Therefore oxidation state of Pt in both the complex ions is +2. Thus name of the complex is :

tetraammineplatinum(II) tetrachloroplatinate(II)

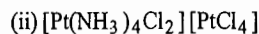

In this complex, coordination number of Pt in complex cation is 6 and in complex anion is 4. Therefore the oxidation states of Pt in complex cation and complex anion are +4 and +2 respectively.

Therefore the name of the complex is :

tetraamminedichloroplatinum(IV) tetrachloroplatinate(II)

Example 3 : $[\text{Cr}(\text{NH}_3)_6][\text{CoF}_6]$

In such type of complexes the common oxidation states of both Cr and Co are +2 and +3 respectively. Thus either of these oxidation states of both would satisfy the charges on complex cation and complex anion. Oxidation states of Cr and Co can be calculated as :

	Complex cation	Complex anion
(i)	$[\text{Cr}(\text{NH}_3)_6]^+$	$[\text{CoF}_6]^-$
	$x + 0 = +1$	$x - 6 = -1$
	$x = +1$	$x = +5$
	Not shown by Cr	Not shown by Co (Incorrect)
(ii)	$[\text{Cr}(\text{NH}_3)_6]^{2+}$	$[\text{CoF}_6]^{2-}$
	$x + 0 = +2$	$x - 6 = -2$
	$x = +2$	$x = +4$
	Shown by Cr	Not shown by Co (Incorrect)

(iii)	$[\text{Cr}(\text{NH}_3)_6]^{3+}$	$[\text{CoF}_6]^{3-}$
	$x = +3$	$x - 6 = -3$
	Shown by Cr	$x = +3$
		Shown by Co (Correct)
(iv)	$[\text{Cr}(\text{NH}_3)_6]^{4+}$	$[\text{CoF}_6]^{4-}$
	$x = +4$	$x - 6 = -4$
	Not shown by Cr	$x = +2$
		Shown by Co (Incorrect)
(v)	$[\text{Cr}(\text{NH}_3)_6]^{5+}$	$[\text{CoF}_6]^{5-}$
	$x = +5$	$x - 6 = -5$
	Not shown by Cr	$x = +1$
		Not shown by Co (Incorrect)
(vi)	$[\text{Cr}(\text{NH}_3)_6]^{6+}$	$[\text{CoF}_6]^{6-}$
	$x = +6$	$x - 6 = -6$
	Not shown by Cr	$x = 0$
		Not shown by Co (Incorrect)

The calculations given above for oxidation states of Cr and Co show that oxidation states of Cr and Co in complex cation and complex anion is +3 which satisfies the charges on complex cation and complex anion and is the common oxidation state for both. Therefore, the name of the complex compounds is :

hexaammine chromium(III) hexafluorocobaltate(III)

Some Examples of Such Type of Complexes are Given Below

(i) $[\text{Co}(\text{en})_3][\text{Cr}(\text{CN})_6]$	<i>tris</i> (ethylenediamine)cobalt(III) hexacyanochromate(III)
(ii) $[\text{Pt}(\text{py})_4][\text{PtCl}_4]$	tetrapyridineplatinum(II) tetrachloroplatinate(II)

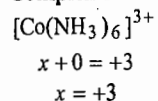
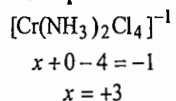

In this complex, it is seen clearly that the charge on complex cation and complex anion will be +3 and -1 respectively. Therefore, oxidation states of Co and Cr can be calculated as :

Complex cation**Complex anion**

The oxidation states of both Co and Cr is +3. Therefore, name of the complex is :

hexaammine cobalt(III) tetraamminedichlorochromate(III)

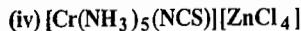

In complexes Zn shows only +2 oxidation state, therefore, charge on complex anion is -2 and, therefore, the charge on complex cation will be +2.

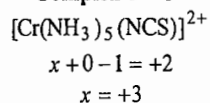
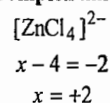
Complex cation**Complex anion**

Oxidation states of Cr = +3

Thus, the name of the complex is :

pentaamminethiocyanato-N chromium(III) tetrachlorozincate(II)

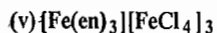

In this complex, it is seen that the charge on complex cation is +3 and charge on complex anion is -1. Therefore, oxidation state of Fe in complex cation and complex anion can be calculated as :

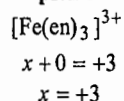
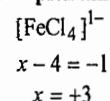
Complex cation**Complex anion**

The oxidation state of Fe in both the complex ions is +3. Therefore, the name of the complex compound is :

tris(ethylenediamine)iron(III) tetrachloroferrate(III)

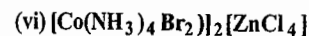

In this complex, charges on complex cation and complex anion are +1 and -2 respectively. Therefore, the oxidation states of cobalt and zinc can be calculated as :

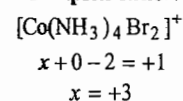
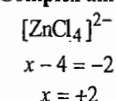
Complex cation**Complex anion**

Therefore, oxidation states of cobalt and zinc are +3 and +2 respectively.

Therefore, the name of the complex is :

tetraamminedibromocobalt(III) tetrachlorozincate(II)

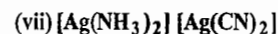

It has been observed experimentally that the elements of group 11 (*i.e.*, Cu, Ag, Au) in +1 oxidation state and Hg in +2 oxidation state form complexes of coordination number 2. Therefore, in this complex oxidation state of Ag is +1 in both the complex ions. Therefore, the name of the complex compound is :

diammine silver(I) dicyanoargentate(I)

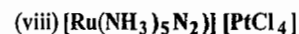

In this complex, coordination number of Pt is 4, therefore, oxidation state of Pt is +2. This indicates that charge on complex anion is -2 and on the complex cation is +2.

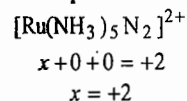
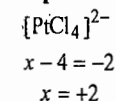
Complex cation**Complex anion**

The oxidation number calculations show that the oxidation state of both Ru and Pt is +2. Therefore, the name of the complex compound is :

pentaamminedinitrogenruthenium(II) tetrachloroplatinate(II)

Naming of Complexes Containing Hydrated Water Molecules

In the coordination compounds which have hydrated water molecules, the number of water molecules are designated in the last of the name of a complex compound separated by a space as shown below :

H_2O	monohydrate
$1\frac{1}{2}\text{H}_2\text{O}$	sesquihydrate
$2\text{H}_2\text{O}$	dihydrate
$3\text{H}_2\text{O}$	trihydrate and so forth

An important example is given below :

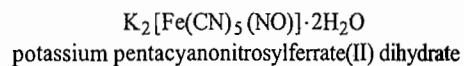

Naming of Geometrical Isomers

Geometrical isomers are named either by using the prefixes *cis-* and *trans-* or *fac-* (*i.e.*, *facial*) and *mer-* (*i.e.*, *meridional*) or by numbering system. If a complex shows only two geometrical isomers, the prefixes *cis-* or *trans-* and *fac-* or *mer-* are used before the name of the compound separating by hyphen. If more than two geometrical isomers are possible for a complex, then only numbering system can be used. For example :

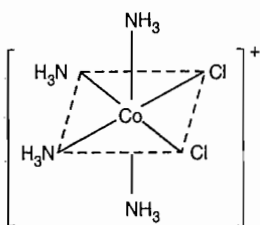

cis-tetraamminedichlorocobalt(III)

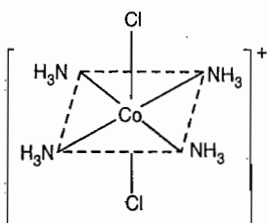

trans-tetraamminedichlorocobalt(III)

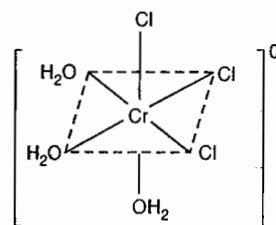

fac-triaquatrichlorochromium(III)

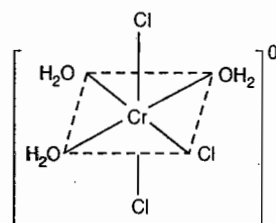

mer-triaquatrichlorochromium(III)

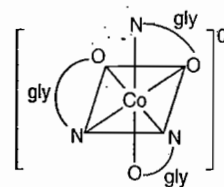

fac-triglycinatocobalt(III)

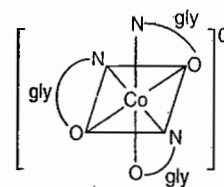

mer-triglycinatocobalt(III)

Naming of Optical Isomers

Optical isomers are designated either by *d* (or *+*) or *l* (or *-*) where *d*- and *l*- are standing for dextrorotatory and levorotatory respectively. For example :

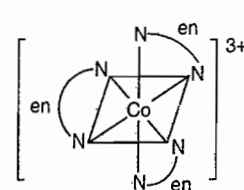

d-tris(ethylenediamine)cobalt(III)

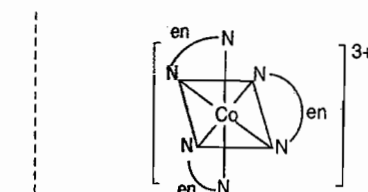

l-tris(ethylenediamine)cobalt(III)

Mirror

3. Oxidation number of Os in $[\text{Os}(\text{PPh}_3)\text{Cl}_3(\text{NEt}_2)]^+$ is:

- (a) +2 (b) +3
(c) +5 (d) +6

4. The IUPAC name of $\text{mer}[\text{Co}(\text{NO}_2)_3(\text{dien})]$ is:

- (a) *mer*-ethylenediaminetritirocoba(III)
(b) *mer*-diethylenetriaminitritirocoba(III)
(c) *mer*-diethylenediaminetritirocoba(III)
(d) *mer*-trinitrodiethylenetriaminitirocoba(III)

5. The IUPAC name of $\text{Na}_3[\text{Fe}(\text{CN})_5\text{NO}]$ is:

- (a) sodium pentacyanonitrosyl iron(II)
(b) sodium pentacyanonitrosium ferrate(I)
(c) sodium nitrosoniumpentacyano ferrate(I)
(d) sodium nitrosylpentacyano ferrate(II)

6. Which one of the following is a correct representation of tetraammine nickel(II) hexacyano ferrate(III)?

- (a) $[\text{Ni}(\text{NH}_3)_4][\text{Fe}(\text{CN})_6]$ (b) $[\text{Ni}(\text{NH}_3)_4]_3[\text{Fe}(\text{CN})_6]_4$
(c) $[\text{Ni}(\text{NH}_3)_4][\text{Fe}(\text{CN})_6]_2$ (d) $[\text{Ni}(\text{NH}_3)_4]_3[\text{Fe}(\text{CN})_6]_2$

7. The IUPAC nomenclature of $\text{Na}[\text{PCl}_6]$ is:

- (a) sodium hexachlorophosphine(V) (b) sodium hexachlorophosphate(V)
(c) sodium hexachlorophosphine (d) sodium hexachlorophosphite(V)

ANSWERS

1. (c) 2. (b) 3. (d) 4. (b) 5. (b) 6. (d) 7. (b)

Subjective Questions

1. Write the IUPAC name of the following complexes:

- (a) $[\text{Pt}(\text{py})_4][\text{PtCl}_4]$ (b) $[\text{Cr}(\text{NH}_3)_6][\text{CoF}_6]$
(c) $[\text{Cr}(\text{en})_3][\text{Ni}(\text{CN})_5]$ (d) $[\text{Co}(\text{NH}_3)_5\text{ONO}]$
(e) $[\text{Cr}(\text{NH}_3)_5\text{CO}_3]\text{Cl}$ (f) $[\text{Ni}(\text{NH}_3)_2(\text{H}_2\text{O})(\text{NO}_2)]\text{Br}$

2. Write the formula of following complexes:

- (a) Pentaammine chromium(III)- μ -hydroxopentaammine chromium(III) chloride
(b) Diammine diaqua dicyano cobalt(III) chloride
(c) Pentaammine isothiocyanato chromium(III) tetrachlorozincate(II)
(d) Sodium dithiosulphatoargentate(I)
(e) Tetraammine carbonato cobalt(III) chloride
(f) Potassium tetrafluoroargentate(I)

4

Theories for Metal-Ligand Bonding in Complexes

There are three theories to explain the nature of bonding in transition metal complexes.

- (1) Valence Bond Theory (VBT) - covalent
- (2) Crystal Field Theory (CFT) - ionic
- (3) Ligand Field Theory (LFT) or Molecular Orbital Theory (MOT) or Adjusted Crystal Field Theory (ACFT) - part

(1) Valence Bond Theory

This theory developed mainly by Pauling. This theory is based on the following assumptions:

- (1) The central metal cation or atom (as the case may be) makes available a number of vacant *s*, *p* and or *d*-orbitals equal to its coordination number to form coordinate covalent bonds with orbitals on the ligands.
- (2) Since the maximum angular overlap of two orbitals forms the strongest bond, therefore, these vacant atomic orbitals of metal are hybridized to form a new set of equivalent bonding orbitals, called hybrid orbitals. These orbitals have same geometry and same energy. These orbitals also have definite directional properties i.e., these orbitals point in the directions of ligands. The geometry and hybridization are related to one another. Once you know the geometry of a complex compound, you automatically know which orbitals of the metal cation or atom uses. The relationship between the geometry of the complex and hybridization is given in Table 4.1.
- (3) The bonding in metal-complexes arises when a filled ligand orbital containing a lone pair of electrons overlaps a vacant hybrid orbital on the metal cation or atom to form a coordinate covalent bond (Figure 4.1).

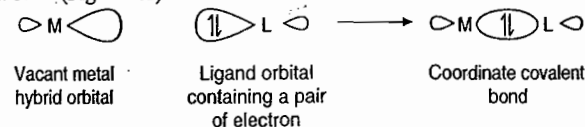

Figure 4.1:

- (4) The magnetic moment (i.e., the number of unpaired electrons) and the coordination number of the metal cation or atom decide the hybridization and geometry of the complex. Therefore, magnetic moment, coordination number, hybridization and geometry are related to one

another. The knowledge of magnetic moment can be of great help in ascertaining the nature of ligands and type of complex.

- (5) Each ligand has at least one orbital containing a lone pair of electrons. Pauling classified the ligands into two categories: (i) strong electron donating ligands or simply strong ligands like CN^- , CO etc. (ii) weak ligands or highly electronegative ligands, like F^- , Cl^- , oxygen containing ligands etc.
- (6) Strong ligands have the tendency to pair up the d -electrons of metal cation or atom to provide the necessary orbitals for hybridization. But the pairing of electrons does not violate the Hund's rule of maximum multiplicity. On the other hand, weak ligands do not have the tendency to pair up the d -electrons *i.e.*, in presence of weak ligands electronic configuration of the d -electrons is same as in free metal cation or atom.
- (7) The bond formed between metal and strong ligand such as CN^- , CO is considered to be covalent. On the other hand, the bond formed between metal and weak or highly electronegative ligand like F^- is not covalent but it is ionic.
- (8) The bond formed between metal and strong ligand like CN^- , CO etc. is considered to be covalent. This would require in many cases the pairing of d -electrons to provide the necessary orbital for hybridization.
- (9) In octahedral complexes, the central metal cation is either d^2sp^3 or sp^3d^2 -hybridized. The d -orbitals involved in d^2sp^3 -hybridization belong to the inner shell *i.e.*, $(n-1)$ d -orbitals and these complexes are called as inner orbital complexes. In case of sp^3d^2 -hybridization, the d -orbitals belong to outer most shell *i.e.*, n d -orbitals and the complexes are called outer orbital complexes. The octahedral complexes involving d^2sp^3 -hybridization are more stable than those of sp^3d^2 . The d -orbitals involved in hybridization in octahedral complexes are $d_{x^2-y^2}$ and d_{z^2} .
- In tetrahedral complexes, the metal cation or atom is either sp^3 or sd^3 -hybridized. The d -orbitals involved in sd^3 -hybridization are d_{xy} , d_{yz} and d_{zx} .
- In square planar complexes, the metal cation is dsp^2 -hybridized. The p - and d -orbitals involved in dsp^2 -hybridization are p_x , p_y and $d_{x^2-y^2}$ leaving p_z and d_{z^2} orbitals projecting above and below the plane of the complex.
- (10) In case of second and third series transition metal complexes, the d -orbitals involved in hybridization are inner orbitals *i.e.*, $(n-1)$ d -orbitals, because the outer d -orbitals *i.e.*, nd orbitals become too diffuse to bond well.
- (11) The complexes having one or more unpaired electrons are paramagnetic and the complexes having only paired electrons are diamagnetic.

Table 4.1 : Hybrid Orbitals for Common Coordination Geometries

C.N	Hybridization	Orbitals Involved	Bond Angle (s)	Geometry	Example
2	sp	s and p_x	180°	Linear	$[\text{Ag}(\text{NH}_3)_2]^+$
3	sp^2	s , p_x and p_y	120°	Triangular planar	$[\text{HgI}_3]^-$

4	sp^3	s , p_x , p_y and p_z	$109^\circ 28'$	Tetrahedral	$[\text{CoCl}_4]^{2-}$, $[\text{NiCl}_4]^{2-}$
4	sd^3	s , d_{xy} , d_{yz} , d_{zx}	$109^\circ 28'$	Tetrahedral	MnO_4^- , $\text{Cr}_2\text{O}_7^{2-}$, CrO_4^{2-}
4	dsp^2 or sp^2d	s , p_x , p_y , $d_{x^2-y^2}$ s , p_x , p_y , $d_{x^2-y^2}$	90° 90°	Square planar Square planar	$[\text{Ni}(\text{CN})_4]^{2-}$ (dsp^2) $[\text{Cu}(\text{NH}_3)_4]^{2+}$ (sp^2d)
5	dsp^3 *	s , p_x , p_y , p_z d_{z^2}	90° , 120°	Trigonal pyramidal	$\text{Fe}(\text{CO})_5$
5	dsp^3	s , p_x , p_y , p_z and $d_{x^2-y^2}$	90° , 90°	Square pyramidal	$[\text{Ni}(\text{CN})_5]^{3-}$
6	d^2sp^3	$4s$, $4p_x$, $4p_y$, $4p_z$, $3d_{x^2-y^2}$ and $3d_{z^2}$	90° , 90°	Inner orbital octahedral	$[\text{Cr}(\text{H}_2\text{O})_6]^{3+}$, $[\text{Fe}(\text{CN})_6]^{4-}$
6	sp^3d^2	$4s$, $4p_x$, $4p_y$, $4p_z$, $4d_{x^2-y^2}$ and $4d_{z^2}$	90° , 90°	Outer orbital octahedral	$[\text{Co}(\text{H}_2\text{O})_6]^{2+}$, $[\text{CoF}_6]^{4-}$

Now let us discuss the valence bond theory for octahedral, tetrahedral and square planar complexes taking some examples :

Octahedral Complexes

(A) Inner Orbital Complexes : Let us discuss inner orbital complexing taking some examples :

1. $[\text{Co}(\text{CN})_6]^{3-}$ ion : In this complex, oxidation state of cobalt is +3. The valence shell electronic configuration of Co^{3+} is $3d^6$. Magnetic measurements indicate that $[\text{Co}(\text{CN})_6]^{3-}$ is diamagnetic. All six $3d$ -electrons are, therefore, paired and occupy three of the five $3d$ -orbitals. The CN^- ligands are strong and, therefore, cause pairing of $3d$ -electrons. The vacant two $3d$ -orbitals combine with the vacant $4s$ and $4p$ -orbitals to form six d^2sp^3 -hybrid orbitals. These six hybrid orbitals overlap with six filled orbitals of ligands, one on each of the ligands and thus six coordinate covalent bonds are formed.

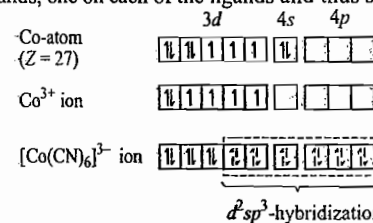

d^2sp^3 -hybridization
octahedral
geometry inner
orbital complex

2. $[\text{Co}(\text{NO}_2)_6]^{4-}$ ion : In this complex ion, oxidation state of cobalt is + 2 and its valence shell electronic configuration is $3d^7$. Magnetic moment measurements indicate that this complex ion is paramagnetic corresponding to presence of one unpaired electron. The NO_2^- ligands are strong, they, therefore, cause pairing of metal $3d$ -electrons. Pauling suggested that two vacant $3d$ -orbitals are made available by promotion of an unpaired electron from a $3d$ -orbital to $5s$ -orbital so that Co^{2+} ion gets d^2sp^3 -hybridized.

The presence of an unpaired electron in $5s$ -orbital is supported by the fact that, $5s$ -orbital has very high energy and the electron present in it is loosely bound and can be removed easily. Experimentally it is also observed that $[\text{Co}(\text{NO}_2)_6]^{4-}$ is oxidized by air or H_2O_2 easily to give $[\text{Co}(\text{NO}_2)_6]^{3-}$. This indicates that the complex $[\text{Co}(\text{NO}_2)_6]^{4-}$ is unstable in air. Thus, this complex should be prepared in inert atmosphere.

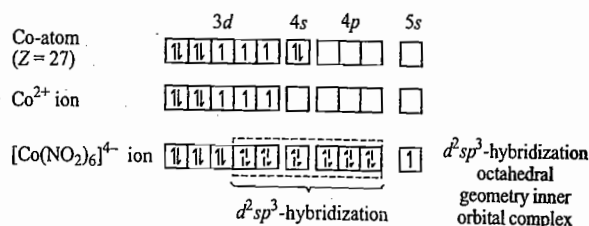

3. $[\text{Mn}(\text{CN})_6]^{3-}$ ion : In this complex ion, oxidation states of Mn is + 3 and its valence shell electronic configuration is $3d^4$. Magnetic measurements show that this complex ion is paramagnetic corresponding to two unpaired electrons. All the four electrons occupy just three of the five $3d$ -orbitals leaving two $3d$ -orbitals vacant. These two vacant $3d$ -orbitals combine with the vacant $4s$ and $4p$ -orbitals to give six d^2sp^3 -hybrid orbitals. These hybrid orbitals form bonds with ligands by accepting six pair of electrons, one pair from each of the six ligands. Since CN^- is a strong ligand and has a tendency to pair up the d -electrons on metal but it causes pairing of two electrons only leaving two electrons as unpaired. If all the electrons become paired, then it will violate the Hund's rule of maximum multiplicity.

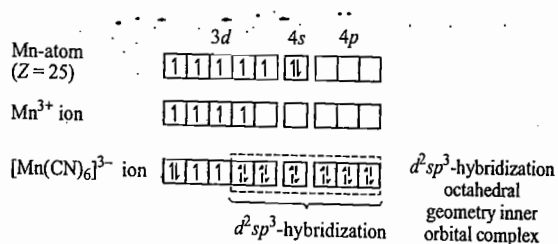

4. $[\text{Cr}(\text{CN})_6]^{3-}$ ion : In this complex ion, oxidation state of Cr is + 3 and its valence shell electronic configuration is $3d^3$. Magnetic measurements show that this complex ion is paramagnetic corresponding to the presence of three unpaired electrons. All the three $3d$ -electrons occupy just three

of the five $3d$ -orbitals leaving two $3d$ -orbitals as vacant. These two vacant orbitals combine with the vacant $4s$ and $4p$ -orbitals to give six d^2sp^3 -hybrid orbitals. These six hybrid orbitals form bonds with ligands by accepting six lone pair of ligands, one pair from each of the six ligands. The three orbitals of the metal cation have three unpaired electrons and are degenerate. Thus, even in the presence of strong ligands pairing of electrons will not occur. If pairing of electrons occur, then it will violate Hund's rule of maximum multiplicity.

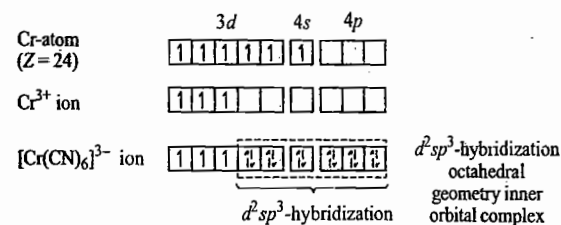

5. $[\text{V}(\text{NH}_3)_6]^{3+}$ ion : In this complex ion, oxidation state of vanadium is + 3 and its valence shell electronic configuration is $3d^2$. Magnetic measurements indicate that this complex ion is paramagnetic corresponding to two unpaired electrons. All the two $3d$ -electrons occupy just two of the five $3d$ -orbitals leaving three $3d$ -orbitals vacant two of which combine with vacant $4s$ and $4p$ -orbitals to give six d^2sp^3 -hybrid orbitals. The d^2sp^3 -hybrid orbitals form bonds with the ligands accepting six pairs of electrons, one pair from each of the six ligands. Out of three $3d$ -unhybridized orbitals, two orbitals have two unpaired electrons one unpaired electron in each and one orbital remains vacant. These three unhybridized $3d$ -orbitals are degenerate. Thus, even in the presence of strong ligands pairing of electrons will not occur. If pairing of electrons occur, then it will violate Hund's rule of maximum multiplicity.

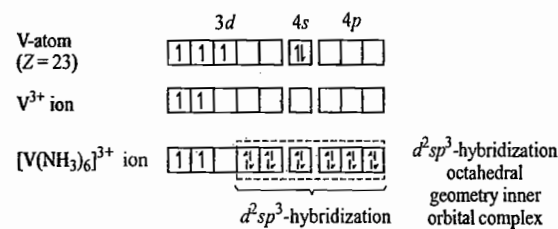

Various inner orbital octahedral complexes are illustrated in Table 4.2.

Table 4.2

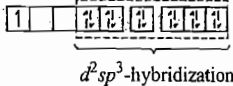
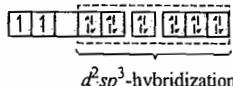
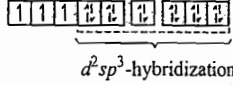
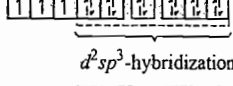
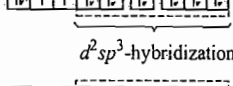
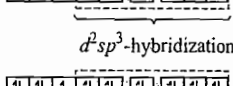
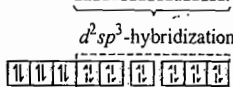
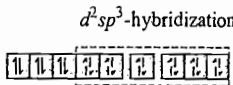
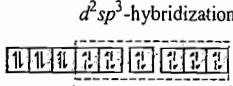
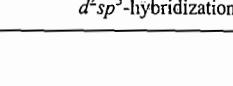
Complex Ion	Oxidation State of Metal	Valence Shell Configuration of Metal Cation	Nature of Ligands	Valence Bond Electrons Description	No. of Unpaired Electrons (n)
$[\text{Ti}(\text{H}_2\text{O})_6]^{3+}$	+3	$3d^1$	weak	 d^2sp^3 -hybridization	1
$[\text{V}(\text{H}_2\text{O})_6]^{3+}$	+3	$3d^2$	weak	 d^2sp^3 -hybridization	2
$[\text{Cr}(\text{H}_2\text{O})_6]^{3+}$	+3	$3d^3$	weak	 d^2sp^3 -hybridization	3
$[\text{Cr}(\text{NH}_3)_6]^{3+}$	+3	$3d^3$	strong	 d^2sp^3 -hybridization	3
$[\text{Cr}(\text{CN})_6]^{4-}$	+2	$3d^4$	strong	 d^2sp^3 -hybridization	2
$[\text{Mn}(\text{CN})_6]^{4-}$	+2	$3d^5$	strong	 d^2sp^3 -hybridization	1
$[\text{Fe}(\text{CN})_6]^{3-}$	+3	$3d^5$	strong	 d^2sp^3 -hybridization	1
$[\text{Fe}(\text{CN})_6]^{4-}$	+2	$3d^6$	strong	 d^2sp^3 -hybridization	0
$[\text{Fe}(\text{CN})_5(\text{NO})]^{2-}$	+2	$3d^6$	$\text{CN}^- \rightarrow$ strong $\text{NO}^+ \rightarrow$ strong	 d^2sp^3 -hybridization	0
$[\text{PtCl}_6]^{2-}$	+4	$5d^6$	weak	 d^2sp^3 -hybridization	0

(B) Outer Orbital Octahedral Complexes: In outer orbital complexes the central metal cation is sp^3d^2 -hybridized. In sp^3d^2 -hybridization, d -orbitals of outer shell (i.e., nd -orbitals) are involved. Let us discuss complexes by taking some examples:

(1) $[\text{CoF}_6]^{3-}$ ion: In this complex ion, oxidation state of cobalt is +3 and its valence shell electronic configuration is $3d^6$. Magnetic moment measurements show that this complex is paramagnetic corresponding to four unpaired electrons. Also, F^- is a weak ligand, there will be no pairing of $3d$ -electrons of the metal cation. Thus, there is no vacant $3d$ -orbital and none of $3d$ -orbitals is available to accept electron pairs from the ligands. Consequently the vacant $4s$, $4p$ and two of the five $4d$ -orbitals combine to give six sp^3d^2 -hybridization. These hybrid orbitals form bonds by accepting six pairs of electrons, one pair from each of the six ligands.

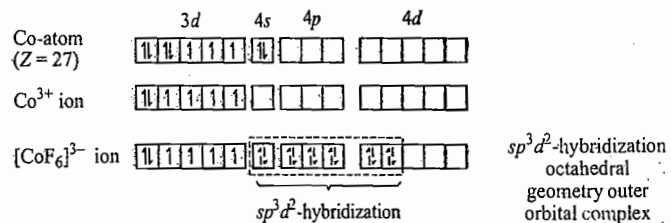

(2) $[\text{Fe}(\text{H}_2\text{O})_5(\text{NO})]^{2+}$ ion: In this complex ion, oxidation state of Fe is +1 because NO exists in +1 oxidation state in complexes of Fe and its valence shell electronic configuration is $3d^6 4s^1$. Magnetic moment measurements of this complex ion indicate that its experimental magnetic moment is 3.89 B.M. which corresponds to three unpaired electrons in the complex ion. The single NO^+ strong ligand has little tendency to pair up the electrons it pairs up only two unpaired electrons. Since H_2O is a weak ligand, therefore, it has no tendency to pair up the electrons and none of the five $3d$ -orbitals is vacant. Therefore, the $4s$, $4p$ and two of the five $4d$ -orbitals (i.e., $4d_{x^2-y^2}$ and $4d_{z^2}$) combine to give six sp^3d^2 -hybrid orbitals. These hybrid orbitals form bonds with six ligands by accepting six pairs of electrons, one pair from each of the six ligands.

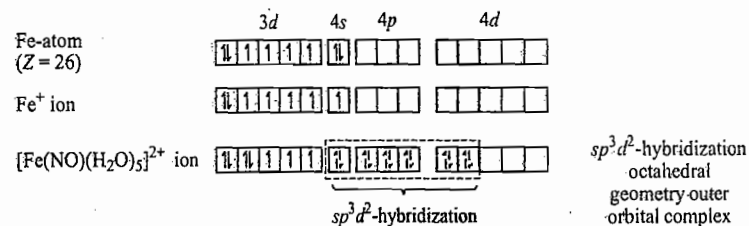

Some outer orbital octahedral complexes are illustrated in Table 4.3.

Table 4.3

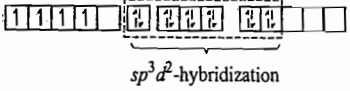
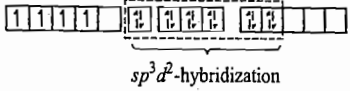
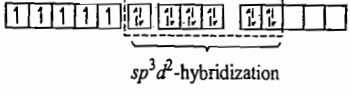
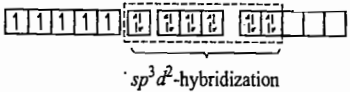
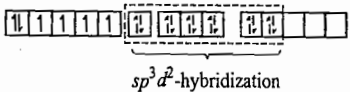
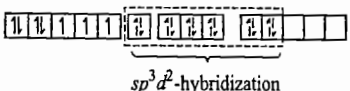
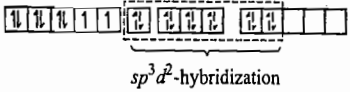
Complex Ion	Oxidation State of Metal	Valence Shell E.C. of Metal Ion	Nature of Ligands	Valence Bond Electrons Description	No. of Unpaired Electrons (n)
$[\text{Cr}(\text{H}_2\text{O})_6]^{2+}$	+2	$3d^4$	weak	 sp^3d^2 -hybridization	4
$[\text{Cr}(\text{NH}_3)_6]^{2+}$	+2	$3d^4$	strong	 sp^3d^2 -hybridization	4
$[\text{Mn}(\text{H}_2\text{O})_6]^{2+}$	+2	$3d^5$	weak	 sp^3d^2 -hybridization	5
$[\text{FeF}_6]^{3-}$ or $[\text{Fe}(\text{H}_2\text{O})_6]^{3+}$	+3	$3d^5$	weak	 sp^3d^2 -hybridization	5
$[\text{CoF}_6]^{3-}$	+3	$3d^6$	weak	 sp^3d^2 -hybridization	4
$[\text{Co}(\text{NH}_3)_6]^{2+}$	+2	$3d^7$	strong	 sp^3d^2 -hybridization	3
$[\text{Ni}(\text{NH}_3)_6]^{2+}$	+2	$3d^8$	strong	 sp^3d^2 -hybridization	2

From the foregoing discussion it is concluded that the octahedral complexes of d^1, d^2, d^3 -metal cations are always inner orbital complexes whether the ligands are weak or strong. The octahedral complexes of d^8, d^9 and d^{10} metal cations are always outer orbital complexes either the ligands are strong or weak. The complexes of d^4, d^5, d^6 and d^7 metal cations are outer orbital complex if the ligands are weak.

Tetrahedral Complexes

In tetrahedral complexes the metal cation is either sp^3 or sd^3 -hybridized. Let us consider the some example to illustrate the hybridization and geometry :

(1) $[\text{NiCl}_4]^{2-}$ ion : In this complex ion, oxidation state of Ni is +2 and its valence shell electronic configuration is $3d^8$. Magnetic moment measurements indicate that it is paramagnetic corresponding to two unpaired electrons. Since Cl^- is a weak ligand, therefore, no pairing of electrons will occur in $3d$ -orbitals. None of the five $3d$ -orbitals is vacant. Vacant $4s$ and $4p$ -orbitals combine to give four sp^3 -hybrid orbitals because $[\text{NiCl}_4]^{2-}$ is a tetrahedral complex ion. These four hybrid orbitals form bonds with four ligand by sharing four pair of electrons, one pair from each of the four ligands.

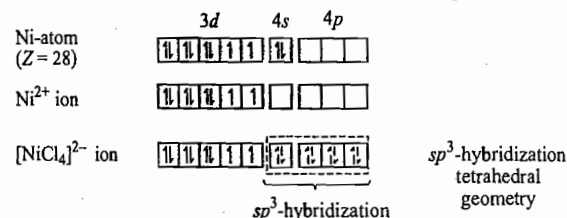

(2) $\text{Ni}(\text{CO})_4$: In this compound oxidation state of nickel is zero and its valence shell electronic configuration is $3d^8 4s^2$. Magnetic moment measurements indicate that $\text{Ni}(\text{CO})_4$ is diamagnetic *i.e.*, it has no unpaired electrons. CO is a strong ligand and has the tendency to pair up the $3d$ -electrons. During the pairing of electrons, the two electrons of $4s$ -orbitals shift into one of the five $3d$ -orbitals. Thus, there is no vacant $3d$ -orbital. Thus, the vacant orbitals available for hybridization are $4s$ and $4p$ to give four sp^3 -hybrid orbitals.

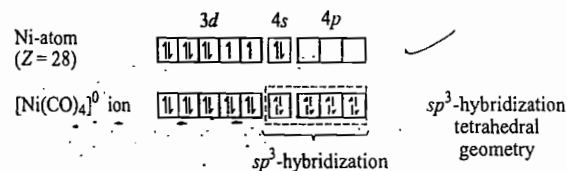

(3) MnO_4^- ion : In this complex ion, oxidation state of Mn is +7. The valence shell electronic configuration of Mn is $3d^5 4s^2$. In Mn^{7+} ion all the five $3d, 4s$ -orbitals are vacant. The vacant $4s$ and three $3d$ -orbitals combine to give four sd^3 -hybrid orbitals. Thus, Mn^{7+} ion is sd^3 -hybridized in this complex ion as shown below :

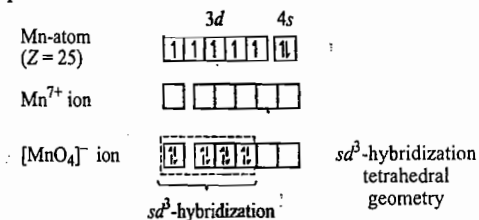

In Mn^{7+} ion energy of vacant $4s$ -orbital becomes lower than that of vacant $3d$ - orbitals (aufbau principle).

In sd^3 - hybridization vacant d_{xy} , d_{yz} and d_{zx} orbitals are involved.

(3) $Cr_2O_7^{2-}$ ion : In this complex ion, oxidation state of Cr is +6 and its valence shell electronic configuration of Cr is $3d^5 4s^1$. Cr^{6+} ion has no electron in $3d$ - orbitals. The $4s$ - and three $3d$ - vacant orbitals of each Cr^{6+} ion combine to give four sd^3 - hybrid orbitals. Thus, each Cr^{6+} ion in $Cr_2O_7^{2-}$ ion is sd^3 - hybridized. One of the seven oxide ions, shares both the Cr^{6+} ions.

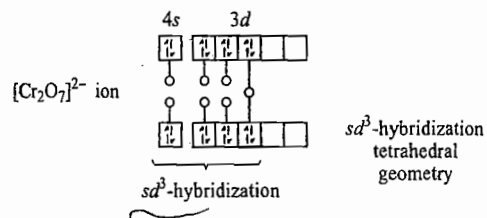

It has no unpaired electron, therefore, it is diamagnetic. Some tetrahedral complexes are illustrated in Table 4.4.

Table 4.4

Complex Ion	Oxidation State	Valence Shell E.C.	Valence Bond Electrons Description	No. of Unpaired Electrons (n)
$[Mn X_4]^{2-}$ ($X = Cl^-, Br^-$)	+2	$3d^5$	sp^3 -hybridization	5
$[FeCl_4]^{2-}$	+2	$3d^6$	sp^3 -hybridization	4
$[CoCl_4]^{2-}$	+2	$3d^7$	sp^3 -hybridization	3
$[Cu X_4]^{2-}$ ($X = Cl^-, Br^-, CNS^-$)	+2	$3d^9$	sp^3 -hybridization	1

$[Cu(CN)_4]^{3-}$	+1	$3d^{10}$	sp^3 -hybridization	0
$[Zn X_4]^{2-}$ ($X = Cl^-, Br^-, I^-$)	+2	$3d^{10}$	sp^3 -hybridization	0

Square Planar Complexes

In square planar complexes, the central metal cation is dsp^2 - hybridized. The dsp^2 - hybrid orbitals point towards the four corners of a square.

Let us consider some examples to discuss the hybridization in square planar complexes :

(1) $[Ni(CN)_4]^{2-}$ ion : In this complex ion, oxidation state of Ni is +2 and its valence shell electronic configuration is $3d^8$. Magnetic moment measurement indicate that this complex ion is diamagnetic *i.e.*, it has no unpaired electrons. Since CN^- is a strong ligands, therefore, these ligands cause to pair up the two unpaired electrons in one d -orbital resulting in a vacant $3d$ -orbital. This vacant $3d$ -orbital gets hybridized with the vacant $4s$ and two of the $4p$ -orbitals to give four dsp^2 - hybrid orbitals. These hybrid orbitals form bonds to the ligands by accepting four pair of ligand electrons, one pair from each of the four ligands.

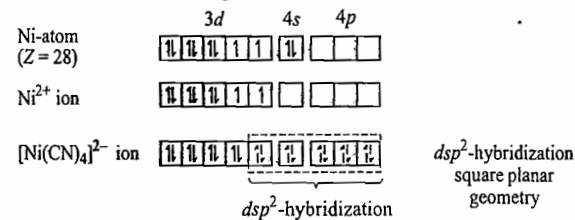

(2) $[Cu(NH_3)_4]^{2+}$ ion : In this ion, oxidation state of copper is +2 and its valence shell electronic configuration is $3d^9$. Magnetic moment measurements indicate that this complex ion is paramagnetic corresponding to presence of one unpaired electron. There is no possibility of pairing of electrons by the ligands even the ligand is strong because there is only one unpaired electron in $3d$ - orbitals. Since coordination number of Cu^{2+} ion in $[Cu(NH_3)_4]^{2+}$ is 4, therefore, according to VBT, Cu^{2+} ion should be sp^3 - hybridized and the structure is tetrahedral.

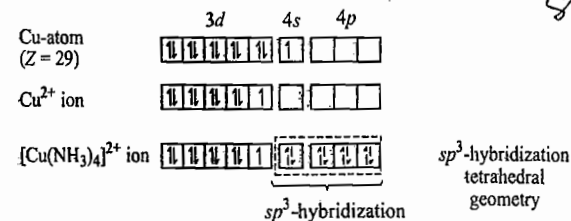

But according to ESR and X-rays structure determination, the structure of $[\text{Cu}(\text{NH}_3)_4]^{2+}$ is found to be square planar. Thus, to make the Cu^{2+} ion dsp^2 -hybridized, it is considered that the unpaired electron in the $3d_{x^2-y^2}$ orbital is to be promoted to $4p_z$ orbital as shown below:

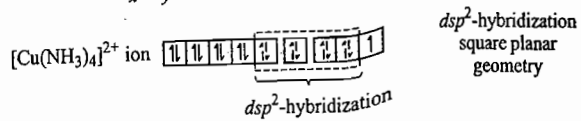

In the above electronic configuration, the unpaired electron is present in the higher energy $4p_z$ orbital and is expected to be lost easily i.e., $[\text{Cu}(\text{NH}_3)_4]^{2+}$ ion may be easily oxidized to $[\text{Cu}(\text{NH}_3)_4]^{3+}$.

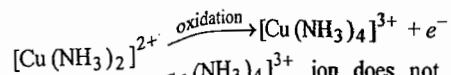

But, experiments have shown that $[\text{Cu}(\text{NH}_3)_4]^{3+}$ ion does not exist i.e., oxidation of $[\text{Cu}(\text{NH}_3)_4]^{2+}$ to $[\text{Cu}(\text{NH}_3)_4]^{3+}$ is not possible.

Finally Huggin suggested that in square planar $[\text{Cu}(\text{NH}_3)_4]^{2+}$ ion, Cu^{2+} ion is sp^2d -hybridized as shown below:



In this configuration one of the three $4p$ -orbitals, $4p_z$ -orbital remains unhybridized i.e., does not participate in hybridization because p_z -orbitals lies above and below the plane of the ion. $[\text{Cu}(\text{py})_2]^{2+}$, $[\text{Cu}(\text{en})_2]^{2+}$, $[\text{Cu}(\text{CN})_4]^{2-}$ complex ions are square planar and Cu^{2+} ion is sp^2d -hybridized. The valence bond electron description of some square planar complexes is given in Table 4.5.

Table 4.5

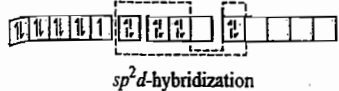
Complex	Oxidation State of Metal	Valence Shell E.C. of Metal Cation	Valence Bond Electrons Description	No. of Unpaired Electrons (n)
$[\text{Ni}(\text{H}_2\text{mg})_2]$	+2	$3d^8$	 dsp^2 -hybridization	0
$[\text{Cu}(\text{CN})_4]^{2-}$	+2	$3d^9$	 sp^2d -hybridization	1

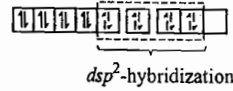
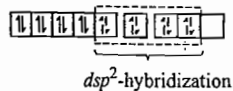
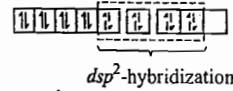
$[\text{PdCl}_4]^{2-}$	+2	$4d^8$	 dsp^2 -hybridization	0
$[\text{PtCl}_4]^{2-}$	+2	$5d^8$	 dsp^2 -hybridization	0
$[\text{Pt}(\text{NH}_3)_4]^{2+}$	+2	$5d^8$	 dsp^2 -hybridization	0

Limitations of VBT

1. It could not explain the nature of ligands i.e., which ligand is strong and which one is weak.
2. It could not explain why the pairing of electrons occurs in the presence of strong ligands.
3. From this theory magnetic moment can be calculated by knowing the number of unpaired electrons but it could not explain the effect of temperature on magnetic moment. It could also not explain why the experimental value of magnetic moment is greater than the calculated in some complexes.
4. It could not explain the distortion in some octahedral complexes like $[\text{Cr}(\text{H}_2\text{O})_6]^{2+}$ and $[\text{Cu}(\text{H}_2\text{O})_6]^{2+}$.
5. It could not explain the colour and electronic spectra of complexes.
6. It could not explain reaction rates and mechanism of reactions of complexes.
7. It could not explain the structure of $[\text{Cu}(\text{NH}_3)_4]^{2+}$ ion.

(2) Crystal Field Theory (CFT)

Valence bond theory is useful to visualize the bonding in complexes but it fails to explain the nature of ligands, colour and electronic spectra, effect of temperature on magnetic moment and magnetic susceptibilities, why some complexes are high spin and others are low spin, stability of complexes. To explain these properties Bethe and van Vleck proposed the crystal field theory. This theory was originally applied to ionic crystals and is, therefore, called crystal field theory.

This theory is based on the following assumptions:

- (1) Ionic ligands such as Cl^- , OH^- , CN^- are regarded as negative point charges (or simply point charges) and the neutral ligands such as H_2O , NH_3 , py are regarded as point dipole (or simply dipoles) because these ligands are dipolar. If the ligand is neutral molecule like H_2O , NH_3 the negative end of the dipole is directed towards the metal ion.

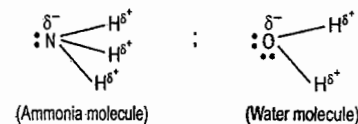

- (2) Metal-ligand bond is not covalent *i.e.*, there is no overlapping of orbitals. Instead the bonding in complexes is purely electrostatic in nature. In complexes two types of electrostatic forces come into account. One is the attraction between the metal cation and the negatively charge ligand or the negative end of the polar ligand (*i.e.*, dipole). The second type of electrostatic interaction is the electrostatic repulsion between the lone pairs of electrons on the ligands and the electrons in the d -orbitals of the metal cation and the repulsion between nuclei of metal cation and the ligands but to a small extent. Another repulsion also comes into account that occurs among the ligands.
- (3) The five d -orbitals in a free metal ion are degenerate (*i.e.*, have same energy). When a complex is formed, the electrostatic field of the ligands destroy the degeneracy of these d -orbitals *i.e.*, these orbitals now have different energies. The orbitals lying in the direction of the ligands are raised in energy more than those lying away from the ligands because of the repulsion between the d -electrons and the ligands.
- In order to understand the CFT, it is necessary to know the geometry and orientations of the five d -orbitals.

Shape of d -orbitals

In fact there are six d -orbitals each of them have four lobes. These orbitals are d_{xy} , d_{yz} , d_{zx} , $d_{x^2-y^2}$, $d_{z^2-x^2}$ and $d_{z^2-y^2}$. The three orbitals d_{xy} , d_{yz} and d_{zx} lie in between the axes and the three orbitals $d_{x^2-y^2}$, $d_{z^2-x^2}$ and $d_{z^2-y^2}$ lie on axes.

In so far as there are only five independent d -orbitals, one of them (the d_{z^2}) is regarded as the linear combination of the $d_{z^2-x^2}$ and $d_{z^2-y^2}$ orbitals (Figure 4.2) because of the fact that these two orbitals have no independent existence.

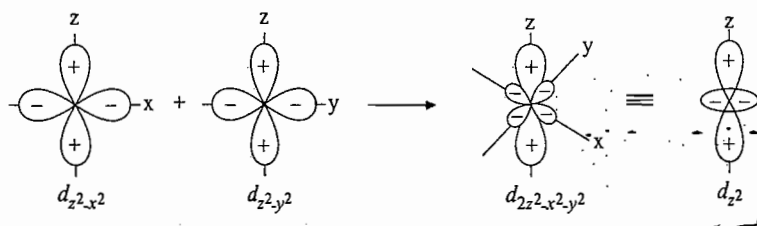

Figure 4.2 Linear combination of $d_{z^2-x^2}$ and $d_{z^2-y^2}$ orbitals to give a d_{z^2} orbital.

The orbital $d_{z^2-x^2}$ has the probability of finding electron along the z - and x -axes whereas the orbital $d_{z^2-y^2}$ has the probability of finding electron along z and y -axes. Therefore, when these two orbitals are combined, the resulting d_{z^2} (or $d_{z^2-x^2-y^2}$) orbital has probability of finding electron along z -axis twice that of along the x - and y -axes. The d_{z^2} orbital also has some fraction of probability along the x - and y -axes. This xy -component has a doughnut shape (*i.e.*, a ring shape). Therefore, the five d -orbitals shown in Figure 4.3 are d_{xy} , d_{yz} , d_{zx} , $d_{x^2-y^2}$ and d_{z^2} .

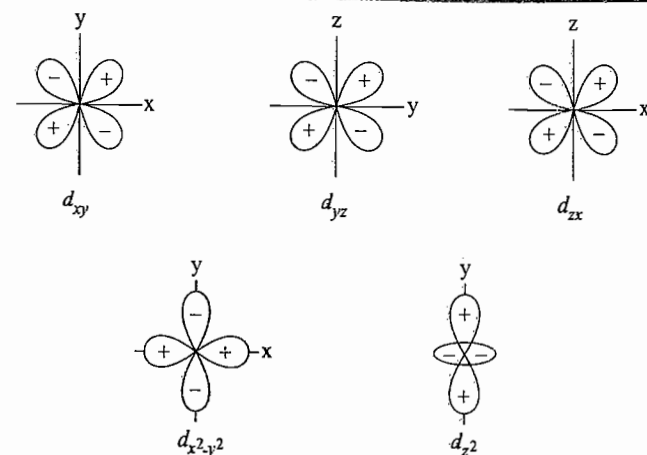

Figure 4.3 Shapes and orientation of d -orbitals.

The three orbitals d_{xy} , d_{yz} and d_{zx} lie in between the axes. These three orbitals lie in xy , yz and zx -planes respectively. The $d_{x^2-y^2}$ orbital on x and y -axes and the d_{z^2} orbital on z -axis. The shape of d_{z^2} is different from the other four.

All the five d -orbitals are gerade because the opposite lobes have inversion centre (*i.e.*, centre of symmetry) with respect to phase of wave functions. The plus (+) and minus (-) signs indicate the different phase of the lobes of orbitals.

Crystal Field Splitting in Octahedral Complexes

In a free (or isolated) metal cation all the five d -orbitals are degenerate (*i.e.*, these have same energy). In an octahedral complex, say $[ML_6]^{n+}$ the metal cation is placed at the centre of the octahedron and the six ligands are at the six corners. These six corners are directed along the cartesian coordinates *i.e.*, along x , y and z -axes (Figure 4.4).

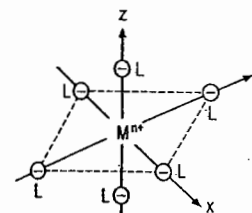

Figure 4.4 Octahedral structure of $[ML_6]^{n+}$ ion.

When all the six ligands are at infinite distance from the metal cation, the five d -orbitals of the free metal cation will not be affected by the ligand electrostatic field and will remain degenerate. When the ligand move towards the metal cation, there are two electrostatic forces. One is the attraction between

metal cation and the ligands and second is electrostatic repulsion between d -electrons of metal cation and lone pairs of electrons on ligands. Greater the force of attraction between the metal cation and the ligands, ligands will be more closer to the metal cation, and hence more will be the repulsion between metal d -electrons and the lone pair of electrons. When the ligands are closer to the metal cation, an electrostatic repulsion also exists among the ligands. These two repulsions cause to adopt the octahedral geometry that locates the ligands at the internuclear distance from the metal cation and as far apart from one another as possible. The force of repulsion between metal d -electrons and the ligands electrons causes to increase in potential energy of the metal d -electrons. Remember that greater the force of repulsion, higher will be the potential energy. If all the six ligands approaching the metal cation surround it spherically symmetric *i.e.*, all the ligands are at equal distance from each of the d -orbitals. The energy of each of the five d -orbitals will raise by the same amount and all the five d -orbitals will still remain degenerate. This is a hypothetical situation and has the average energy of a set of d -orbitals. In an actual octahedral complex, spherically symmetrical field is never obtained. Therefore, all the five d -orbitals are not affected to same extent. Since the two orbitals ($d_{x^2-y^2}$ and d_{z^2}) point directly towards the ligands and three orbitals (d_{xy} , d_{yz} and d_{zx}) point in between the path of the approaching ligands. Therefore, the $d_{x^2-y^2}$ and d_{z^2} orbitals will be more strongly repelled than the d_{xy} , d_{yz} and d_{zx} orbitals. Therefore, the energy of $d_{x^2-y^2}$ and d_{z^2} orbitals will be raised and that of other three orbitals which lie far away from the ligands will be decreased relative to hypothetical energy state (Figure 4.5). The five d -orbitals which were degenerate in free metal cation are now split into two sets of orbitals of different energies, a higher energy level with two orbitals ($d_{x^2-y^2}$ and d_{z^2}) having the same energy and a lower level with three equal energy orbitals (d_{xy} , d_{yz} and d_{zx}). The set of $d_{x^2-y^2}$ and d_{z^2} orbitals is referred to as e_g set which is doubly degenerate and the set of d_{xy} , d_{yz} and d_{zx} orbital is referred to as t_{2g} set which is triply degenerate.

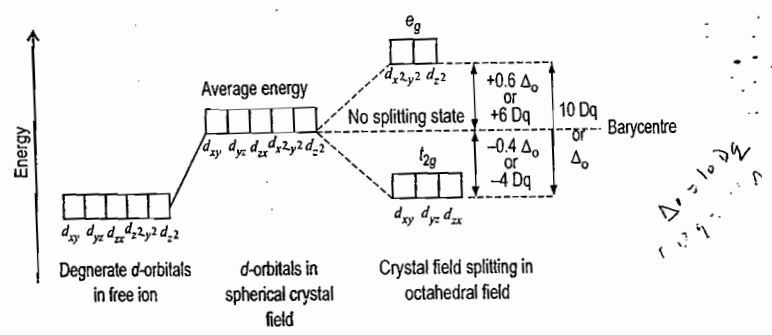

Figure 4.5

Since the distance between the metal cation and the ligands has remained the same, the net potential energy (or average energy) of the system must remain the same as that of the spherical field before splitting. This state of average energy is called the barycentre.

The separation of five d -orbitals of metal cation into two set of different energies is called crystal field splitting. The energy difference between two sets of orbitals which arise from an octahedral field is measured in terms of the parameter Δ_o or $10 Dq$, where o in Δ_o stands for octahedral.

Since the energy of barycentre remains constant, the total energy decrease of t_{2g} set must be equal to the total energy increase of e_g set. Therefore, since there are two e_g orbitals, they must increase by $0.6 \Delta_o$ or $6 Dq$ and the three t_{2g} orbitals must decrease by $0.4 \Delta_o$ or $4 Dq$ per electron. The decrease in energy of t_{2g} orbitals stabilizes the complex by $0.4 \Delta_o$ and the increase in energy of e_g orbitals destabilizes the complex by $0.6 \Delta_o$.

Crystal Field Splitting in Tetrahedral Complexes

A regular tetrahedral geometry is obtained when a metal cation or atom is placed at the centre of a cube and four ligands occupy the alternate corners of the cube as shown in Figure 4.6

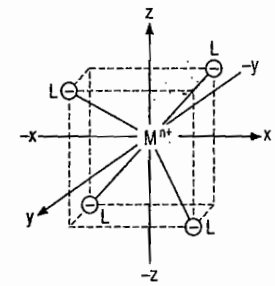

Figure 4.6 Tetrahedral arrangement of four ligands around the metal cation in a cube.

The x , y and z - axes are passed through the centres of the faces of the cube. None of the ligands approach directly any of the metal d -orbitals. Instead they all approach to some degree in between the metal d - orbitals.

It can be seen from the Figure 4.7 that the three orbitals (d_{xy} , d_{yz} , and d_{zx}) are far apart by $\frac{l}{2}$ ($= 0.5 l$) from each of the ligands whereas the two orbitals ($d_{x^2-y^2}$ and d_{z^2}) are relatively little far apart by $\frac{l\sqrt{2}}{2}$ ($= 0.71 l$), where l is the length of the side of the cube. In other words, we can say that the d_{xy} , d_{yz} and d_{zx} orbitals are half ($\frac{l}{2}$) the side of cube away from the ligands whereas the $d_{x^2-y^2}$ and d_{z^2} orbitals are half the diagonal ($\frac{l\sqrt{2}}{2}$) of the face of cube away.

This indicates that the ligands come closer to the orbitals directed to edges of the cube (*i.e.* d_{xy} , d_{yz} and d_{zx}) than to those directed to the centers of the cube (*i.e.* $d_{x^2-y^2}$ and d_{z^2}). Each of the five d - orbitals in tetrahedral field is represented in Figure 4.7.

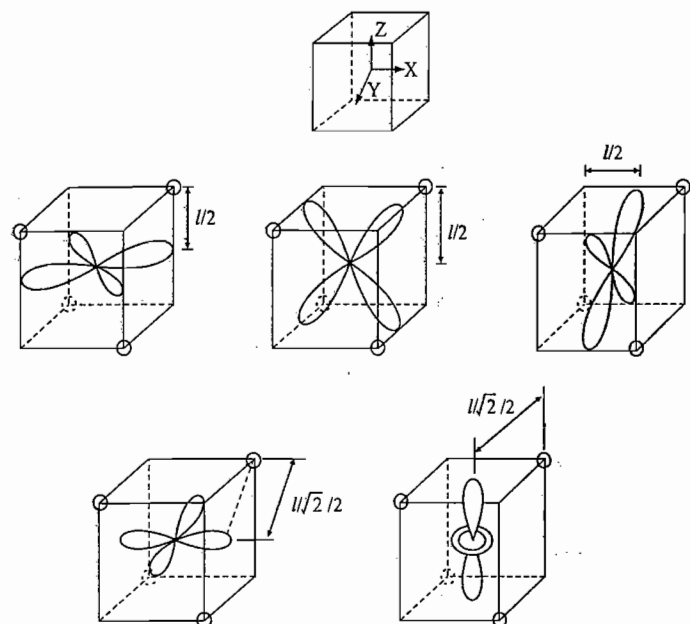

Figure 4.7.

The d_{xy} , d_{yz} and d_{zx} orbitals of metal cation, experience more repulsion from the ligands and are of higher energy than those of the $d_{x^2-y^2}$ and d_{z^2} orbitals. To maintain the rule of centre of gravity, the d_{xy} , d_{yz} and d_{zx} orbitals (referred to as the t_2 set) are $0.4 \Delta_t$ above the barycentre and the $d_{x^2-y^2}$ and d_{z^2} orbitals (referred to as e set) are $0.6 \Delta_t$ below the barycentre. The g subscript is not used with t_2 and e sets because the tetrahedral complexes have no inversion centre. The difference in energy of e and t_2 sets is represented by Δ_t , where t stands for tetrahedral. The crystal field splitting in tetrahedral complexes is shown Figure 4.8.

The crystal field splitting is just reverse of the octahedral complexes.

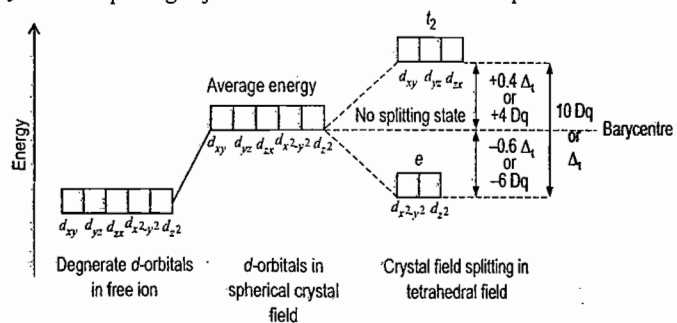

Figure 4.8 Crystal field splitting in tetrahedral complexes.

The crystal field splitting in tetrahedral complexes is smaller than that in octahedral complexes because there are two third ligands of octahedral complexes and none of the ligands approach the metal d -orbitals. For the same metal, ligand and metal-ligand distance, it is observed that $\Delta_t = \frac{4}{9} \Delta_o$ because :

- The number of ligands are $2/3$ of the octahedral complex, therefore, the splitting of the d -orbitals is also two third.
- None of the ligands point directly towards any of the five d -orbitals. Therefore, the splitting is reduced by roughly two third. In tetrahedral and octahedral complexes the d_{xy} , d_{yz} and d_{zx} orbitals are at 45° i.e., at equal distance from the ligands. Therefore, in both the complexes, each ligand repels these orbitals in equal amount. In octahedral complexes, the ligands approach directly to $d_{x^2-y^2}$ and d_{z^2} orbitals and repel them strongly. But in tetrahedral complexes these orbitals are at $\frac{\sqrt{2}l}{2} = 0.71l$ (it approximately equal to the $2/3$) as compared to that of octahedral complexes.

Therefore, in tetrahedral complexes, the ligands repel these orbitals $2/3$ times than that of octahedral complexes. Thus, due to this fact, splitting decreases by $2/3$ rd in tetrahedral complexes as compare to octahedral complexes.

$$\text{Therefore, } \Delta_t = \frac{2}{3} \times \frac{2}{3} \times \Delta_o \text{ or } \Delta_t = \frac{4}{9} \Delta_o$$

Tetrahedral complexes are always high spin because : (i) $\Delta_t = \frac{4}{9} \Delta_o$ i.e., Δ_t is much smaller than octahedral splitting Δ_o and (iii) Δ_t is always less than the pairing energy. Due to these two reasons no pairing of electrons occurs in d^3 , d^4 , d^5 , d^6 and d^7 tetrahedral complexes. Therefore, the tetrahedral complexes of these configurations are always high spin whether the ligands are strong or weak.

Factors Affecting the Magnitude of Δ

There are several factors that affect the magnitude of splitting (Δ) of d -orbitals by the surrounding ligands.

(1) **Oxidation State of the Metal Cation** : The higher the oxidation state of the metal cation, the greater will be the magnitude of Δ .

The higher oxidation state of the metal causes the ligands to approach more closely to it and, therefore, the ligands cause more splitting of metal d -orbitals. For example,

$$\Delta_o \text{ for } [\text{Co}(\text{H}_2\text{O})_6]^{2+} = 9200 \text{ cm}^{-1}$$

$$\text{and } \Delta_o \text{ for } [\text{Co}(\text{H}_2\text{O})_6]^{3+} = 20760 \text{ cm}^{-1}$$

(2) **Same Oxidation State of Metal Cation but the Number of d -electrons is Different** : In general, for a given series of transition elements (say $3d$ -series), in complexes having the metal cation with the same oxidation states but with different number of electrons in d -orbitals, the magnitude of Δ_o decrease with increase in the number of d -electrons. It is due to the fact that the higher number of d -electrons prevents the ligands to come closer the metal cation. For example,

$$\text{For } [\text{Co}(\text{H}_2\text{O})_6]^{2+}, \Delta_o = 9200 \text{ cm}^{-1} \text{ (} 3d^7 \text{)}$$

$$\text{For } [\text{Ni}(\text{H}_2\text{O})_6]^{2+}, \Delta_o = 8500 \text{ cm}^{-1} \text{ (} 3d^8 \text{)}$$

(3) **Principal Quantum Number (n) of the d -orbitals of the Metal Cation** : In case of complexes having the metal cations with same oxidation states and same number of d -electrons, the magnitude of Δ for analogous complexes within a given group increases about 30% to 50% from $3d$ to $4d$ and by about the same amount from $4d$ to $5d$. It is because :

(i) On moving $3d$ to $4d$ and $4d$ to $5d$, the size of the d -orbitals increases and electron density decreases in them. Therefore, the ligands can approach the metal cation with larger d -orbital more closely.

(ii) There is less steric hindrance round a larger metal cation :

For example : For $[\text{Co}(\text{NH}_3)_6]^{3+}$, $\Delta_o = 23000 \text{ cm}^{-1}$

For $[\text{Rh}(\text{NH}_3)_6]^{3+}$, $\Delta_o = 34100 \text{ cm}^{-1}$

For $[\text{Ir}(\text{NH}_3)_6]^{3+}$, $\Delta_o = 41200 \text{ cm}^{-1}$

(4) **Nature of Ligands** : The ligands are classified as **weak and strong ligands**. The ligands which cause a small degree of splitting of d -orbitals are called **weak ligands** and the ligands which cause a large splitting are called **strong ligands**. The common ligands have been arranged in order of their increasing crystal field splitting power to cause splitting of d -orbitals from a study of their effects on the spectra of transition metal ions.

$\text{I}^- < \text{Br}^- < \text{S}^{2-} < \text{SCN}^- < \text{Cl}^- < \text{N}_3^- < \text{F}^- < \text{urea} < \text{OH}^- < \text{C}_2\text{H}_5\text{OH} < \text{C}_2\text{O}_4^{2-} <$

$\text{O}^{2-} < \text{H}_2\text{O} < \text{NCS}^- < \text{gly} < \text{NH}_3, \text{py} < \text{en}, \text{SO}_3^{2-} < \text{NH}_2\text{OH} < \text{bpy}, \text{phen} <$

$< \text{NO}_2^- < \text{CH}_3^-, \text{C}_6\text{H}_5^- < \text{R}_3\text{P} < \text{CN}^- < \text{CO}$

This order is usually called as **spectrochemical series**.

The order of the field strength of the common ligands is **independent** of the nature of the metal cation and the geometry of the complex.

(5) **Number of Ligands** : The magnitude of crystal field splitting (Δ) increases with increase of the number of ligands. For example, $\Delta_o > \Delta_t$.

Though number of ligands in square planar complexes is smaller than that of octahedral complexes, the magnitude of Δ_{sp} is greater than Δ_o . It is because of the fact that square planar complexes are formed by much strong ligands with d^8 -metal cation of $3d$ -series transition metals cation and $4d$ or $5d$ -series d^8 transition metal cation with either weak or strong ligands. The very strong ligands and $4d$ or $5d$ -series transition metal cations are responsible for higher crystal field splitting. Also, in square planar complexes of d^8 -metal cations, the $d_{x^2-y^2}$ orbital with two electrons is stabilized and the vacant $d_{z^2-y^2}$ orbital is destabilized.

Crystal Field Splitting in Lanthanoid Complexes

The seven f -orbitals of lanthanoids in their octahedral complexes are also split like d -orbitals of transition metal complexes. The crystal field splitting of f -orbitals is smaller than that of d -orbitals in octahedral complexes. The $4f$ -orbitals are buried in deep, therefore, the ligands can not approach close enough to the $4f$ -orbital to cause much crystal field splitting.

$\Delta_o > \Delta_t$ ✓

Distribution of d -electrons in Octahedral Complex

The distribution of d -electrons in t_{2g} and e_g orbitals depends upon the magnitude of Δ_o . When the magnitude of Δ_o is relatively small, then it is assumed that all the five d -orbitals (i.e., t_{2g} and e_g sets) are degenerate (i.e., have same energy). The distribution of d -electrons in t_{2g} and e_g sets takes place according to Hund's rule of maximum multiplicity i.e., pairing of electrons will take place only when each of five d -orbitals is singly filled. Thus, in complexes having small value of Δ_o the first three electrons occupy the t_{2g} orbitals, 4th and 5th electrons occupy the e_g orbitals, 6th, 7th and 8th electrons occupy the t_{2g} orbitals and the last two electrons (i.e., 9th and 10th) occupy the e_g orbitals. This can be shown as :

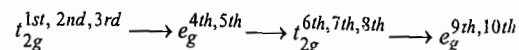

In these complexes no pairing of electrons will take place i.e., arrangement of d -electrons remain same as in free metal cation.

The complexes in which the magnitude of Δ_o is large, the energies of t_{2g} and e_g orbitals differ significantly and the distribution of d -electrons in t_{2g} and e_g orbitals does not obey the Hund's rule of maximum multiplicity. In these complexes the first six electrons occupy the t_{2g} orbitals and the remaining four electrons occupy the e_g orbitals. This can be shown as :

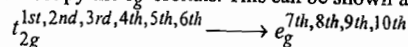

In these complexes the pairing of electrons takes place in t_{2g} orbitals for d^4, d^5, d^6 and d^7 configuration. Whether the value of Δ_o is small or large, there is no difference in the d -electron configuration for d^1, d^2, d^3, d^8, d^9 and d^{10} systems i.e., for these system there is no pairing of electron in octahedral complexes.

Weak Field (or Ligand) or High Spin or Spin Free Complexes

In weak field octahedral complexes of $3d$ -series transition metals with oxidation number $\leq +3$, the value of Δ_o is small and there will be no pairing of d -electrons. Therefore, in the weak field complexes of d^4, d^5, d^6 and d^7 -configuration, there is no pairing of electrons. These complexes have maximum number of unpaired electrons. These complexes having maximum number of unpaired electrons are called high spin or spin free complexes. The term high spin or spin free is used because these complexes have same number of spin as in d -orbitals of free metal cations.

Strong Field (or Ligand) or Low Spin or Spin Paired Complexes

In strong field octahedral complexes of $3d$ -series transition metals with oxidation number, in general $\geq +2$, the value of Δ_o is large. In the strong field complexes of d^4, d^5, d^6 and d^7 -configurations pairing of d -electrons will take place in t_{2g} orbitals according to Hund's rule. These complexes having maximum number of paired electrons are called low spin or spin paired complexes. The term low spin or spin paired is used because these complexes have more number of paired electrons (or spin) than that of free metal cations.

It is to be noted that weak field octahedral complexes always are not the high spin complexes. The metal cation of $3d$ -transition series with oxidation number of $\geq +4$ and the $4d$ - and $5d$ -series transition metal cations always form low spin complexes with weak ligands. For example, $[\text{Ni F}_6]^{2-}$ ion (oxidation

state of Ni is +4) is low spin and diamagnetic, though F^- is a weak ligand. $[Rh(H_2O)_6]^{3+}$ is low spin and diamagnetic, though H_2O is a weak ligand. An exception is observed for 3d-series transition metals in which Co^{3+} forms low spin complexes with H_2O and O^{2-} , though H_2O and O^{2-} are the weak ligands.

Pairing Energy

The energy required to force the two unpaired electrons in one orbital is called the pairing energy.

When more than one electrons are paired, P becomes the mean pairing energy. It may be obtained from the analysis of electronic spectra.

If $\Delta_o > P$, it favours the low spin complexes,

If $\Delta_o < P$, it favours the high spin complexes,

If $\Delta_o = P$, high spin and low spin complexes equally exist.

In general, for 4d- and 5d-series transition metal complexes, magnitude of Δ_o is greater than that of P .

Distribution of d-electrons in Tetrahedral Complexes

The magnitude of Δ_t in tetrahedral complexes is very small. Therefore, it is considered that energy of e and t_2 orbitals is nearly same i.e., both the e and t_2 sets are degenerate. Distribution of d-electrons in e and t_2 orbitals will take place according to Hund's rule i.e., pairing of electrons will take place only when each of the five d-orbitals is singly occupied. The first two electrons occupy the e orbitals, 3rd, 4th and 5th electrons occupy the t_2 orbitals, 6th and 7th electrons occupy the e -orbitals and the last three electrons will occupy the t_2 orbitals. It can be shown as :

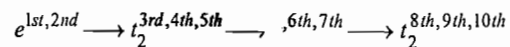

For tetrahedral complexes, $\Delta_t < P$.

Crystal Field Stabilization Energy in Octahedral Complexes

In an octahedral complex, the d-orbitals of the metal cation are split into two sets of different energies, t_{2g} of lower energy and e_g of higher energy. The separation between these two sets is equal to $\Delta_o (=10Dq)$. The t_{2g} set has an energy of $-0.4\Delta_o (= -4Dq)$ and the e_g set has an energy of $+0.6\Delta_o (= +6Dq)$ relative to the barycentre. Minus (-) and plus (+) signs indicate decrease and increase in energy relative to the barycentre respectively. The complex ion with one electron in one of the t_{2g} orbitals has an energy of $-0.4\Delta_o$ relative to the barycenter. This indicates that in a complex ion of d^1 -configuration $0.4\Delta_o$ energy is released. This released energy is called the crystal field stabilization energy (CFSE) of the complex ion.

For d^1 complex, electronic configuration is $t_{2g}^1 e_g^0$.

$$CFSE = -0.4 \times 1 \Delta_o = -0.4 \Delta_o$$

For d^2 complex, electronic configuration is $t_{2g}^2 e_g^0$.

$$CFSE = -0.4 \times 2 \Delta_o = -0.8 \Delta_o$$

For d^3 complex, electronic configuration is $t_{2g}^3 e_g^0$.

$$CFSE = -0.4 \times 3 \Delta_o = -1.2 \Delta_o$$

exception $Co^{3+} \rightarrow low\ spin$

For d^4 high spin complex, electronic configuration is $t_{2g}^3 e_g^1$.

$$CFSE = -0.4 \times 3 + 0.6 \times 1 \Delta_o = -0.6 \Delta_o$$

Thus, for a d^n high spin complex with electronic configuration $t_{2g}^p e_g^q$.

$$CFSE = [-0.4p + 0.6q] \Delta_o$$

Since no pairing of d-electrons occurs in high spin complexes, therefore, no pairing energy is involved in CFSE.

For low spin complexes of d^4, d^5, d^6 and d^7 metal ion, pairing of electrons occurs in t_{2g} orbital. To pair up the two electrons in an orbital, an extra energy is required which is called as pairing energy (P). Therefore, for d^4 low spin complex, electronic configuration is $t_{2g}^4 e_g^0$.

$$CFSE = [-0.4 \times 4 + 0.6 \times 0] \Delta_o + P \\ = -1.6 \Delta_o + P$$

For d^5 low spin complex, electronic configuration is $t_{2g}^5 e_g^0$. In this case four electrons are forced to pair up in two different orbitals of t_{2g} set.

$$\text{Therefore, } CFSE = [-0.4 \times 5 + 0.6 \times 0] \Delta_o + 2P \\ = -2.0 \Delta_o + 2P$$

For d^n low spin octahedral complexes with electronic configuration $t_{2g}^p e_g^q$

$$CFSE = [-0.4p + 0.6q] \Delta_o + mp$$

Where p and q are the number of electrons in t_{2g} and e_g orbitals respectively.

m = Number of pairs of electrons caused by the ligands.

P is the mean pairing energy. The required pairing energy is compensated from CFSE.

Let us illustrate the difference in calculation of CFSE of some high spin and low spin complexes.

(i) For d^6 high spin electronic configuration is $t_{2g}^4 e_g^2$.

$$CFSE = [-0.4p + 0.6q] \Delta_o \\ = [-0.4 \times 4 + 0.6 \times 2] \Delta_o \\ = -0.4 \Delta_o$$

In this case, no pairing energy is included because no pairing of electrons is caused by the ligand. Though it has one pair of electrons but it is not caused by the ligand. This pair was already present in d-orbitals as shown below :

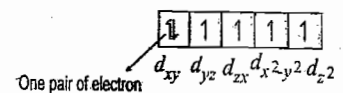

For d^6 low spin octahedral complex, the electronic configuration is $t_{2g}^6 e_g^0$.

$$CFSE = [-0.4 \times 6 + 0.6 \times 0] \Delta_o + 2P \\ = -2.4 \Delta_o + 2P$$

In this case there are three pairs of electrons but only two are caused by the ligands and one was already present in d - orbitals.

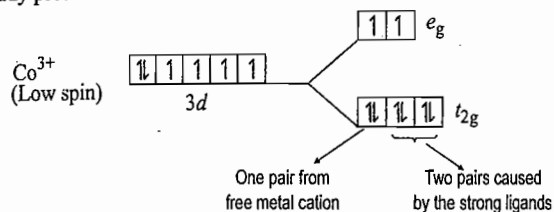

The CFSE's of d^1 to d^{10} high spin and low spin complexes are given in Table 4.6.

Table 4.6 : CFSE Values for Octahedral Complexes of d^1 to d^{10} Metal Cations

System	Arrangement of electrons free metal cation	CFSE for High spin Complexes	CFSE for d^1 to d^3 and d^8 to d^{10} complexes	CFSE for Low spin Complexes
d^1	1-----		$t_{2g}^1 e_g^0$ 1--- ($-\frac{2}{5}\Delta_o$)	
d^2	11-----		$t_{2g}^2 e_g^0$ 11--- ($-\frac{4}{5}\Delta_o$)	
d^3	1111-----		$t_{2g}^3 e_g^0$ 111--- ($-\frac{6}{5}\Delta_o$)	
d^4	11111-----	$t_{2g}^3 e_g^1$ 1111 ($-\frac{3}{5}\Delta_o$)		$t_{2g}^4 e_g^0$ 1111 ($-\frac{8}{5}\Delta_o + P$)
d^5	111111-----	$t_{2g}^3 e_g^2$ 1111 (0)		$t_{2g}^5 e_g^0$ 1111 ($-\frac{10}{5}\Delta_o + 2P$)
d^6	111111-----	$t_{2g}^4 e_g^2$ 1111 ($-\frac{2}{5}\Delta_o$)		$t_{2g}^6 e_g^0$ 1111 ($-\frac{12}{5}\Delta_o + 2P$)
d^7	111111-----	$t_{2g}^5 e_g^2$ 1111 ($-\frac{4}{5}\Delta_o$)		$t_{2g}^6 e_g^1$ 1111 ($-\frac{9}{5}\Delta_o + P$)
d^8	111111-----		$t_{2g}^6 e_g^2$ 1111 ($-\frac{6}{5}\Delta_o$)	
d^9	111111-----		$t_{2g}^6 e_g^3$ 1111 ($-\frac{3}{5}\Delta_o$)	
d^{10}	111111-----		$t_{2g}^6 e_g^4$ 1111 (0)	

Crystal Field Stabilization Energy in Tetrahedral Complexes

In a tetrahedral complex, the d - orbitals of the metal cation are split into two sets of different energies, e of lower energy and t_2 of higher energy. The separation between these two sets is equal to Δ_t . The e set has an energy of $-0.6\Delta_t$ and the t_2 set has an energy of $+0.4\Delta_t$ relative to the barycentre. For a d^n tetrahedral complex with $e^p t_2^q$ configuration,

$$\begin{aligned} \text{CFSE} &= [-0.6p + 0.4q] \Delta_t \\ &= [-0.6p + 0.4q] \times \frac{4}{9} \Delta_o \quad (\because \Delta_t = \frac{4}{9} \Delta_o) \\ &= [-0.27p + 0.18q] \Delta_o \end{aligned}$$

Since tetrahedral complexes are high spin and no pairing of d - electrons occurs ($\Delta_t < P$). Therefore, no pairing energy is included in the above equation. The CFSE values of tetrahedral complexes of d^1 to d^{10} metal ions is given in Table 4.7

Table 4.7 : CFSE Values for Tetrahedral Complexes

System	Electronic distribution in e and t_2 orbitals	CFSE
d^1	$e^1 t_2^0$	$-0.27\Delta_o$
d^2	$e^2 t_2^0$	$-0.54\Delta_o$
d^3	$e^2 t_2^1$	$-0.36\Delta_o$
d^4	$e^2 t_2^2$	$-0.18\Delta_o$
d^5	$e^2 t_2^3$	0
d^6	$e^3 t_2^3$	$-0.27\Delta_o$
d^7	$e^4 t_2^3$	$-0.54\Delta_o$
d^8	$e^4 t_2^4$	$-0.36\Delta_o$
d^9	$e^4 t_2^5$	$-0.18\Delta_o$
d^{10}	$e^4 t_2^6$	0

Tetragonal Distortion or Jahn-Teller Distortion

The six coordinated complexes in which all the six distances between metal cation and the ligands are same and said to be regular octahedral complexes. A complex will be regular octahedral when the electronic arrangement in t_{2g} and e_g orbitals is symmetric (*i.e.*, both t_{2g} and e_g orbitals are electronically non-degenerate). It is because of the fact that symmetrically arranged electrons will repel all the six ligands equally.

When either t_{2g} or e_g orbitals are asymmetrically filled *i.e.*, either t_{2g} or e_g orbitals are electronically degenerate the regular octahedral geometry is not the stable but it transforms into a distorted octahedral geometry.

The e_g orbitals point directly towards the ligands, therefore, when e_g orbitals are electronically degenerate (*i.e.*, unsymmetrically filled), some ligands are repelled more than the others. Therefore, there is a significant distortion in octahedral complexes. On the other hand, the t_{2g} orbitals lie in between the ligands, therefore, the electronically degenerate t_{2g} orbitals cause a very small distortion.

In general, the distortion that occurs in octahedral complexes is the tetragonal distortion. A tetragonal distortion occurs when the two *trans* ligands on the z -axis in an octahedral complex, say ML_6 , are moved either towards the metal ion or away from the metal ion or atom. Motion of the *trans*-ligands along the z -axis towards the metal cation produces a tetragonal compression and motion of these ligands away from the metal cation produces a tetragonal elongation. The shape of regular octahedral, tetragonally compressed and tetragonally elongated complexes are shown in Figure 4.9.

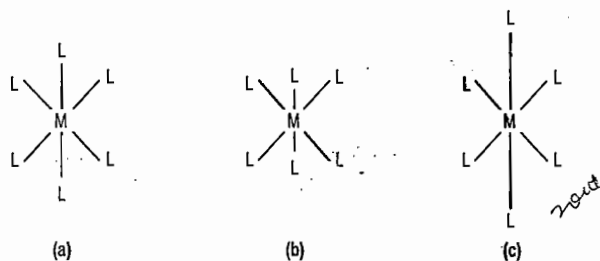
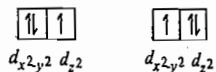
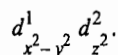

Figure 4.9 (a) Regular octahedral (b) Tetragonal compression (c) Tetragonal elongation

The term tetragonal distorted is derived from the fact that when viewed along the z -axis, an octahedral complex looks like a tetragon. The condition which cause such type of distortion was described by the Jahn-Teller theorem. This theorem states that any non-linear molecule in an electronically degenerate state is unstable and the molecule becomes distorted in such a way as to remove degeneracy, lower its symmetry and lower the energy.

The term electronically degenerate state refers to the situation in which an electrons can be arranged in more than one orbitals of equivalent energy. This situation arises when the degenerate orbitals are unsymmetrically filled. For example, in octahedrally coordinated Cu^{2+} ion, e_g^3 configuration is electronically degenerate because it has two possible arrangements of electrons *i.e.*, $d_{x^2-y^2}^2 d_{z^2}^1$ or



Electronically degenerate states for e_g^3 configuration.

If there is only one possible arrangement of an electron, then this situation is called electronically non-degenerate. The d^3 , for example, configuration in octahedral symmetry is non-degenerate and

symmetric. Only one arrangement is possible for three electrons because it is not possible to put two electrons in one orbital which violates the Hund's rule of maximum multiplicity.



Single arrangement for d^3 -configuration

In a regular octahedral field, the e_g orbitals (*i.e.*, $d_{x^2-y^2}$ and d_{z^2}) are degenerate. However, if the e_g orbitals are asymmetrically filled *i.e.*, either $d_{x^2-y^2}$ or d_{z^2} orbital contains one electron more than the other, then the e_g orbitals are split. If the d_{z^2} orbital contains one electron more than the $d_{x^2-y^2}$ orbital then the ligands approaching along z -axis will be repelled more than the ligands approaching along x - and y -axes. It is because of the fact that electron density in d_{z^2} orbital is greater than that of $d_{x^2-y^2}$ orbital. Therefore, the ligands along the z -axis are moved away from the metal cation relative to those on x and y -axes which move towards the metal cation. The reason for distance between metal cation and the ligands to be shorter on x - and y -axes is that the ligand-ligand repulsion is decreased as the ligands move away from the metal cation on z -axis. Therefore, distance between the metal cation and the ligands on z -axis becomes larger and the distances between metal cation and ligands on x and y -axes become shorter. Thus, the complex undergoes a tetragonal elongation (*i.e.*, z -out distortion).

Since the ligands on z -axis are at larger distance from metal cation than that of the ligands on x and y -axes. Therefore, the d_{z^2} orbital will experience a decrease in repulsion from the ligands and, therefore, energy of the d_{z^2} orbital will decrease and hence the d_{z^2} orbital is stabilized. The $d_{x^2-y^2}$ orbital will experience an increase in repulsion from the ligands resulting in an increase in energy and hence the $d_{x^2-y^2}$ will, therefore, be destabilized, with the barycentre remaining constant. In a similar way the energies of orbitals having z -component (*i.e.*, d_{yz} and d_{zx}) will decrease and that of d_{xy} will increase and a part of the degeneracy in the t_{2g} -orbitals is removed. Therefore, the overall result is that the e_g orbitals split into two levels; an upper $d_{x^2-y^2}$ and a lower d_{z^2} , and the t_{2g} orbitals is split into two levels, an upper, d_{xy} and a lower doubly degenerate (d_{yz} and d_{zx}). The tetragonal elongation is generally called the tetragonal distortion and is observed in most of the tetragonal distorted complexes. Crystal field splitting in tetragonal elongation (z -out) is shown in Figure 4.10.

If the $d_{x^2-y^2}$ orbital contains one electron more than the d_{z^2} orbital then the ligands approaching along x and y -axes will be repelled more than the ligands approaching along the z -axis. It is because of the fact that the electron density in $d_{x^2-y^2}$ orbital is greater than that of d_{z^2} orbital. Therefore, the ligands along the x - and y -axes are moved away from the metal cation relative to those on z -axis which move towards the metal cation. The reason for the distance between metal cation and the ligands to be shorter on z -axis is that the ligand-ligand repulsion is decreased as ligands move away from the metal cation on x - and y -axes. Therefore, the distance between the metal cation and the ligands on x - and y -axes becomes larger and become shorter on z -axis. Therefore, the complex undergoes a tetragonal compression (*i.e.* z -in distortion).

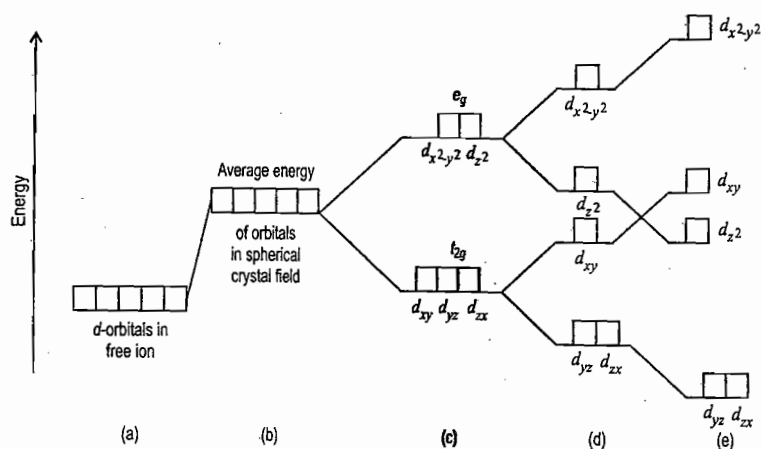

Figure 4.10 (a) Degenerate d -orbitals in free metal ion (b) Degenerate d -orbital in spherical field (c) Splitting of d -orbitals in octahedral field (d) Splitting of d -orbitals in tetragonal elongation (e) Splitting of d -orbitals in tetragonal compression

Since the ligands on x - and y -axes are at longer distance from metal cation than that of the ligands on z -axis, therefore, the $d_{x^2-y^2}$ orbital will experience a decrease in repulsion from the ligands and, therefore, energy of $d_{x^2-y^2}$ orbital will decrease. The d_{z^2} orbital will experience an increase in repulsion from the ligands resulting in an increase in energy, with the barycentre remaining constant. In a similar way the energies of the orbitals having x - and y -component (d_{xy} orbital) will decrease and that of having z -component (*i.e.*, d_{yz} and d_{zx}) will increase. The crystal field splitting in tetragonal compression (or z -in) complexes is shown in Figure 4.11.

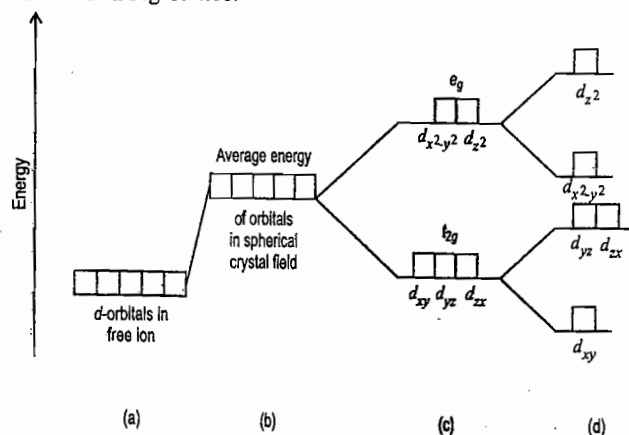

Figure 4.11 (a) Degenerate d -orbitals in free metal ion (b) Degenerate d -orbital in spherical field (c) Splitting of d -orbitals in octahedral field (d) Splitting of d -orbitals in tetragonal compression

Since in tetragonal compression, four ligands on x - and y -axes repel the high density of electrons in $d_{x^2-y^2}$ orbital whereas in tetragonal elongation only two ligands on z -axis repel the high density of electrons in d_{z^2} orbital. Therefore, there is more repulsion in tetragonal compression than that of tetragonal elongation. Therefore, tetragonal elongation is more stable than tetragonal compression. Thus, tetragonal elongation is known to be a tetragonal distortion.

The significant Jahn-Teller distortions are generally observed in high spin d^4 ($t_{2g}^3 e_g^1$), low spin d^7 ($t_{2g}^6 e_g^1$) and d^9 ($t_{2g}^6 e_g^3$) configurations in the octahedral geometry because in these configurations e_g orbitals are electronically degenerate and point towards the ligands directly. Some examples of compounds which undergo strong Jahn-Teller distortion in octahedral field are CrF_2 and MnF_3 ($d^4, t_{2g}^3 e_g^1$), NaNiO_2 (Lowspin, $d^7 t_{2g}^6 e_g^1$), some copper (II) compounds such as $\text{CuF}_2, \text{CuCl}_2, \text{CuBr}_2, \text{CuCl}_2 \cdot 4\text{H}_2\text{O}$, ($d^9, t_{2g}^6 e_g^3$). In all these compounds the metal cations are octahedrally surrounded by the ligands and e_g orbitals are unsymmetrically filled, therefore, there are two longer bonds on z -axis and four shorter bonds on x - and y -axes.

The Jahn-Teller theorem does not predict which type of distortion will take place.

A Ni (II) complex surrounded by four strong and two weak ligands undergoes tetragonal distortion but not due to Jahn-Teller distortion because e_g orbitals ($d_{x^2-y^2}$ and d_{z^2}) are not electronically degenerate. The varying electron repulsions between the non-equivalent ligands and the d -electrons of the metal cation split the e_g orbitals to a great extent and t_{2g} to a small extent as shown in Figure 4.12.

In this case the magnitude of Δ exceeds the pairing energy (P). If all the six ligands are weak, then Ni (II) form a regular octahedral complex. On the other hand, if all the ligands are strong then Ni (II) form a square planar complex.

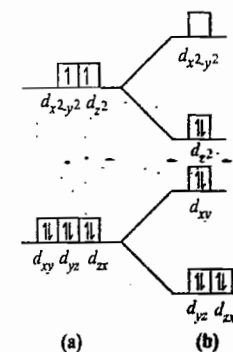

Figure 4.12 Electronic arrangement in : (a) Weak octahedral field and (b) Tetragonal Ni(II) with four strong and two weak ligands.

The octahedral complexes in which t_{2g} orbitals are electronically degenerate (*i.e.*, asymmetrically filled) also undergo Jahn-Teller distortions but the distortions are very weak to be observed because the t_{2g} orbitals do not point directly at the ligands and relatively less affected by the ligands. The d^1, d^2 , low

spin d^4 and d^5 , high spin d^6 and d^7 octahedral complexes undergo slight or weak Jahn-Teller distortions. The octahedral complex of d^1 configuration shows z -in distortion. In this case z -out distortion does not remove the degeneracy, since even after distortion there are still two d_{yz} and d_{zx} orbitals which are available for the electron to occupy.

The octahedral complex of d^2 configuration shows z -out distortion. The two orbitals d_{zx} and d_{yz} having one electron each remove the degeneracy since both these two orbitals have z -component and repel the ligands more strongly on z -axis than the ligands on x - and y -axes.

For the same reason, relatively weak distortions are expected in tetrahedral complexes with d^3 , d^4 , d^8 and d^9 configurations. In the d^3 and d^8 tetrahedral complexes one of the t_2 orbitals has one electron more than the others which causes an elongation in the tetrahedron. On the other hand, in d^4 and d^9 tetrahedral complexes, one of the three t_2 orbitals has one electron less than the others. This situation causes a flattening of the tetrahedral complex.

Static and Dynamic Jahn-Teller Distortions

Some complexes show tetragonal distortion under all conditions *i.e.*, in solid as well as in solution, either at lower or relatively higher temperatures. This distortion is called the static Jahn-Teller distortion. In these complexes the splitting of t_{2g} and/or e_g orbitals is quite high so that the thermal energy available will not be sufficient to affect the population of orbitals in a distorted geometry. This type of Jahn-Teller distortion occurs when e_g orbitals are electronically degenerate. Hence, this distortion is strong and permanent.

There are some exceptions to the Jahn-Teller distortion in which certain physical properties correspond to symmetric structure when distortions are expected. In these complexes no distortion can be detected at room temperature because the direction of distortion (say an elongation of one axis of an octahedron) randomly moves among the available symmetry axes of the complexes more rapidly than the physical measurement. In these complexes the thermal energy available at room temperature causes to equalize the population of the complex ion in the tetragonal elongated and tetragonal compressed geometries. This is called as dynamic Jahn-Teller distortion. Thus, the physical measurement detects an average structure with no or weak distortion. The distortion can be detected at freezing temperature because cooling of the compound will show the oscillations enough resulting in a single distorted structure. Dynamic Jahn-Teller distortion occurs in complexes in which splitting of t_{2g} and/or e_g orbitals is small.

For example :

The complex $[\text{Ti}(\text{H}_2\text{O})_6]^{3+}$ and $[\text{Fe}(\text{H}_2\text{O})_6]^{2+}$ show dynamic Jahn-Teller distortion and appear octahedral. In these complexes both the types of geometries (*i.e.*, tetragonal elongation and tetragonal compression) exist in equilibrium. In these complexes the distortion is small since the degeneracy occurs in t_{2g} orbitals.

Static JTD
stay + permanent



Dynamic

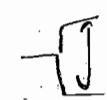

Square Planar Complexes

In an octahedral complex of Ni (II) with weak ligands, the electronic configuration of Ni (II) is $t_{2g}^6 e_g^2$ *i.e.*, t_{2g} and e_g orbitals are symmetrically filled, the electron density in d_{z^2} orbital along z -axis is greater than that of $d_{x^2-y^2}$ orbital along the x - and y - axes because d_{z^2} orbital is the linear combination of $d_{z^2-x^2}$ and $d_{z^2-y^2}$ orbitals. The electron density in d_{z^2} orbital will repel the ligands on z -axis more strongly whereas the electron density in $d_{x^2-y^2}$ orbital will repel the ligands on x - and y -axes to a lesser extent. Therefore, the distance between metal cation and ligand on z -axis is larger than that on x - and y -axes. Thus, energy of d_{z^2} orbital becomes lower relative to the $d_{x^2-y^2}$ *i.e.*, there is splitting to e_g orbitals. But in case of weak field complexes like $[\text{Ni}(\text{H}_2\text{O})_6]^{2+}$ and $[\text{Ni}(\text{NH}_3)_6]^{2+}$ the splitting is small because charge on metal cation is not high and the ligands are also not too strong. Therefore, these complexes are considered to be regular octahedral and the energy of d_{z^2} and $d_{x^2-y^2}$ will be same *i.e.*, e_g orbitals are degenerate. But if the ligands are sufficiently strong, the difference in energy between these two orbitals becomes larger and the unpaired electron in the $d_{x^2-y^2}$ orbital can drop down and pair with the electron already in the d_{z^2} orbital. Now the $d_{x^2-y^2}$ orbital becomes empty. Therefore, strong ligands can approach the metal cation along x - and y -axes without any difficulty as the $d_{x^2-y^2}$ orbital is empty. The ligands approaching the metal cation along z -axis experience very strong repulsions from the filled d_{z^2} orbital. Thus, only four ligands can form bonds with the metal cation.

The amount of tetragonal elongation and the splitting of d -orbitals depends upon the nature of metal cation and the ligands. The metal cations with d^8 configuration form square planar complex with strong ligands such as CN^- . Ni(II) form square planar complex $[\text{Ni}(\text{CN})_4]^{2-}$ with strong CN^- ligands. Since (i) crystal field splitting for $4d$ - and $5d$ - series transition metals and for highly charged metals is very large, (ii) ligands repulsions are minimized due to large size of the metals. Therefore, all the complexes of Pd (II), Pt (II), Au (III) are square planar irrespective of the nature of the ligands *i.e.*, whether the ligands are weak or strong. The crystal field splitting in square planar complexes is shown in Figure 4.10

In square planar complexes of Co (II), Ni (II) and Cu (II) the energy of d_{z^2} orbital is nearly same as d_{yz} and d_{zx} orbitals whereas in square planar complex of Pd (II), Pt (II) and Au (III), energy of d_{z^2} orbital is lower than that of d_{yz} and d_{zx} orbitals.

$$\Delta_{sp} = \Delta_1 + \Delta_2 + \Delta_3$$

The spectroscopic results have shown that

$$\Delta_{sp} = 1.3 \Delta_0 \quad (\text{i.e., } \Delta_{sp} > \Delta_0)$$

Consequences of Jahn-Teller Distortion

(1) Stability of Cu^{2+} Complexes :

For a given ligand, the relative stability of complexes with divalent metal ions of first transition series follow the order $\text{Ba}^{2+} < \text{Sr}^{2+} < \text{Ca}^{2+} < \text{Mg}^{2+} < \text{Mn}^{2+} < \text{Fe}^{2+} < \text{Co}^{2+} < \text{Ni}^{2+} < \text{Cu}^{2+} > \text{Zn}^{2+}$. This series is called the Irving-William series. The extra stability of Cu(II) complexes is

due to Jahn-Teller distortion. During the distortion two electrons are lowered in energy while only one is raised an equal amount of energy.

- (2) The complex $[\text{Cu}(\text{en})_3]^{2+}$ is unstable because Jahn-Teller distortion causes strain into ethylenediamine molecule attached along z-axis (Figure 4.13).

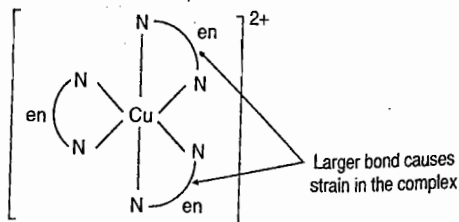

Figure 4.13

In the similar manner trans- $[\text{Cu}(\text{en})_2(\text{H}_2\text{O})_2]^{2+}$ is more stable than the cis- $[\text{Cu}(\text{en})_2(\text{H}_2\text{O})_2]^{2+}$ because Jahn-Teller distortion causes strain in ethylenediamine molecule along z-axis in cis- $[\text{Cu}(\text{en})_2(\text{H}_2\text{O})_2]^{2+}$ (Figure 4.14).

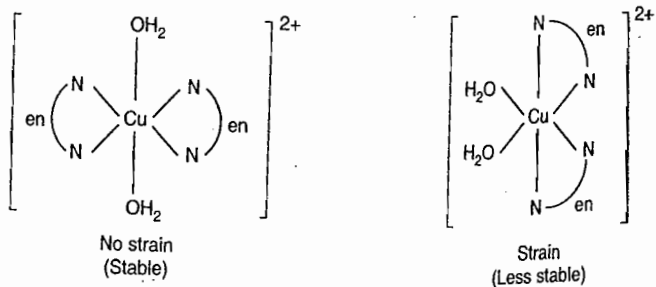

Figure 4.14

- (3) In the crystalline KCuF_3 , the two Cu—F distances on z-axis are 1.96 Å and the remaining four Cu—F distances in xy -plane are at 2.07 Å. It is due to Jahn-Teller compression.

- (4) Complexes of Au (II) ion are unstable and undergo disproportionation to Au (I) and Au (III) whereas the complex of Cu (II) and Ag (II) are comparatively more stable. It can be expected to be the same stability of Au (II), Cu(II) and Ag (II) complexes since all have d^9 configuration and undergo Jahn-Teller distortion. Since Δ value increases on moving down the group, therefore, Δ value for Au (II) complexes is maximum among the three. The high value of Δ causes a high destabilization of the last electron in the $d_{x^2-y^2}$ orbital. Therefore, Au (II) becomes extremely reactive and can undergo either oxidation to Au (III), a d^8 system or reduction to Au (I), a d^{10} system. The Au (III) forms a square planar complex whereas Au (I) forms a linear complex.

- 5) The splitting of absorption bands in the electronic spectra of complex due to Jahn-Teller distortion.

Applications of CFSE

(1) **Enthalpy of Hydration of Transition Metal Ions** : In an aqueous solution, the metal cations are surrounded by polar water molecules. This process is called as hydration. There are six water molecules in the primary hydration sphere around the metal cation to form an octahedral aqua complex. Hydration energy is the energy released when gaseous metal cations get hydrated.

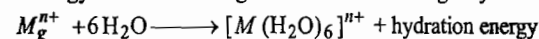

Hydration energy of a metal cation increases with increase in effective nuclear charge and decrease in ionic radii because these two factors brings the water molecules closer to the metal cation, M^{n+} resulting in the increased electrostatic attraction between the metal cation and the water molecules. For dipositive transition metal cation of 3d-series, the effective nuclear charge increases and ionic radii decrease across a period. We expect the electrostatic attraction between metal cation and the water molecules increases regularly along the transition metal series. Therefore, the hydration energy should increase regularly from Ca^{2+} to Zn^{2+} and a straight line should be obtained as shown by dotted line in Figure 4.15. In fact there are some deviations from a linear relationship. When a dipositive or tripisitive metal cation of 3d-series transition metal gets hydrated, a high spin octahedral aqua complex is formed. Therefore, not only the hydration energy but CFSE is also evolved. Thus, the experimental hydration energy is the sum of theoretical hydration energy and CFSE.

$$\text{Experimental hydration energy} = \text{Theoretical or expected hydration energy} + \text{CFSE}$$

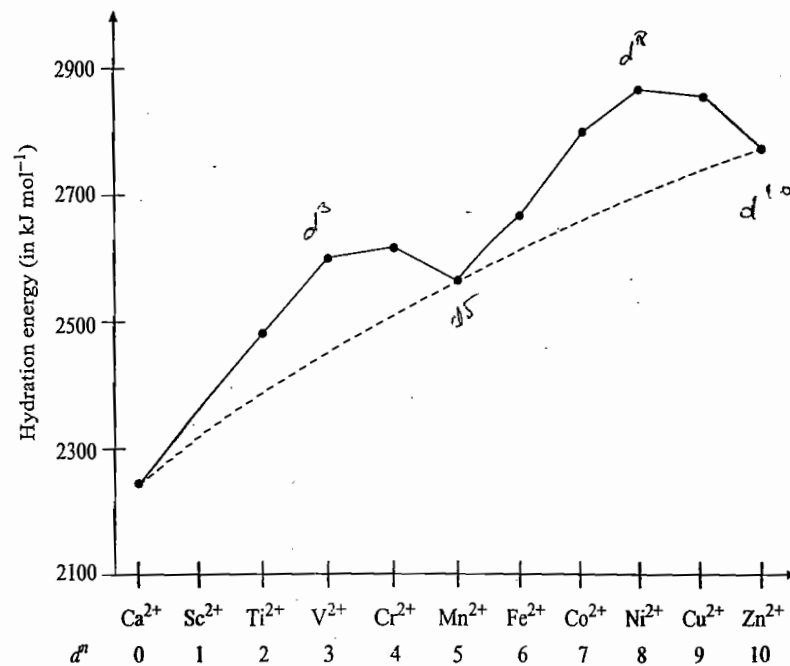
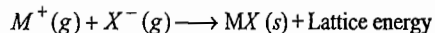

Figure 4.15

If the experimental hydration energies for divalent metal ions of the 3d-transition elements are plotted as a function of atomic number, a double humped curve is obtained (Figure 4.15). The two humps in such a curve are due to addition or contribution of CFSE to the expected hydration energy.

Since the CFSE of Ca (II), Mn (II) and Zn (II) ions in high spin octahedral complex is zero. Therefore, the hydration energies of these ions lie on the straight line and does not deviate from the experimental value. For a particular metal cation it is possible to calculate the net contribution of CFSE to the hydration enthalpy.

(2) **Lattice Energy** : Lattice energy is the change in energy when one mole of an ionic crystal is formed from its constituent gaseous ions.



From the Born Lande's equation :

$$\text{Lattice energy (U)} = -\frac{N_0AZ^+Z^-}{r_0} \left(1 - \frac{1}{n}\right)$$

$$\text{i.e., Lattice} \propto \frac{Z^+Z^-}{r_0}$$

Where N = Avogadro number, A = Madelung constant which depends upon the geometry of the crystal, Z^+ and Z^- are the charges on cation and anion respectively, r_0 = interionic distance, n = Born exponent.

According to Born Lande's equation, the lattice energy of an ionic crystal increases with increase in product of Z^+ and Z^- and decreases in interionic distance (r_0). The lattice energy for halides of divalent metal ions of the 3d-transition elements should increase from Ca^{2+} to Zn^{2+} ion and a straight line should be observed as shown by dotted line in Figure 4.16. In fact there are some deviations from a linear relationship. Some transition metal compounds have higher measured lattice energy (obtained by calculations using Born Haber cycle) than that of expected (calculated by Born Lande's equation). In contrast the experimental and theoretical lattice energies for main group are in close agreement because these compounds do not have CFSE.

In the ionic crystal of halides of divalent or trivalent metal ions of 3d-series transition elements, the metal cations occupy octahedral voids. Therefore, the coordination number of the metal cation is six. The arrangement of halides around the metal cation is analogous to the high spin octahedral complexes. Therefore, the CFSE contributes to the experimental lattice energy. Thus, the contribution of CFSE causes the higher experimental lattice energy than the expected. Since CFSE values for different metal cations are different, therefore, experimental lattice energy increases irregularly from CaX_2 to ZnX_2 . If the experimental lattice energies for CaCl_2 to ZnCl_2 are plotted as a function of atomic number, a double humped curve is obtained (Figure 4.16).

Since CFSE for Ca^{2+} (d^0), high spin Mn^{2+} (d^5) and Zn^{2+} octahedral field is zero. Thus, ions Ca^{2+} , Mn^{2+} and Zn^{2+} lie on the straight line.

For a weak field octahedral field, V^{2+} (d^3) and Ni^{2+} (d^8) have the greatest CFSE ($-1.2 \Delta_o$). Therefore, these two ions show two maxima on the curve above the straight line.

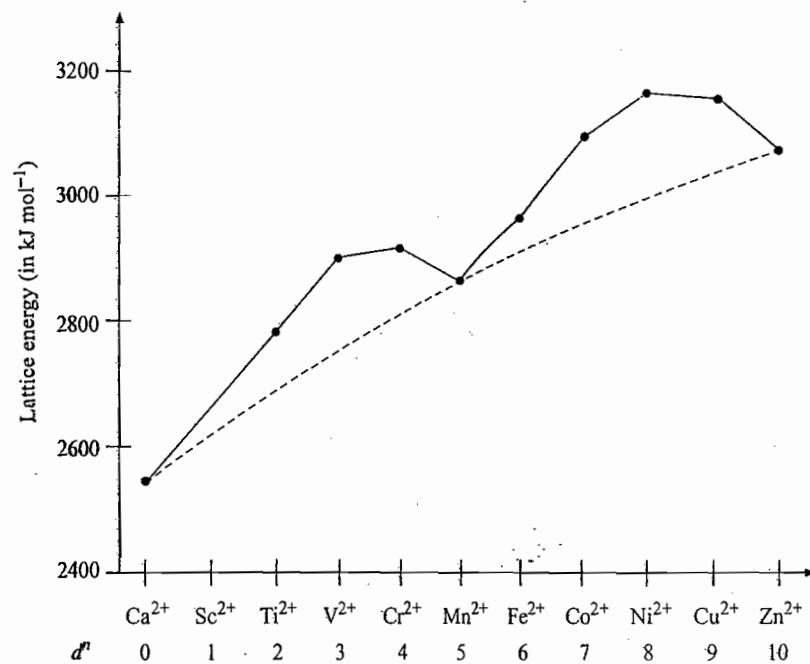

Figure 4.16

The correct value of lattice energy can be calculated by subtracting the CFSE from experimental lattice energy.

Similar plots are obtained for the lattice energies of other MX_2 and MX_3 crystal.

(3) Ionic Radii of Divalent Metal Ions of 3d-Series Transition Elements :

The ionic radii of divalent and trivalent metal cations of 3d-series transition metals in the low spin or high spin octahedral field might be expected to decrease regularly from Ca^{2+} to Zn^{2+} because the increasing effective nuclear charge and poor shielding effect of d -electrons cause the increase of force of attraction between metal cation and the ligands and the ligands may approach the metal cation more closely. But some ions show discrepancies from this regular trend of decreasing ionic radii.

The ionic radii of Ca^{2+} , Mn^{2+} and Zn^{2+} ions in a weak octahedral field decrease smoothly with increasing nuclear charge because these ions are screened by a spherical charge distribution. The d^1 , d^2 and d^3 ions have smaller radii either in weak or strong field than expected because electron occupy t_{2g} orbitals which lie in the region between the ligands. The nuclei of these ions are less shielded than if they had a spherical distribution of electron. However, their ionic radii in octahedral field decreases from d^1 to d^3 ions as the nuclear charge increases. In weak field octahedral complexes of d^4 and d^5 ions electrons are added successively to the e_g orbitals. The first e_g electron causes an increase of the relative radius of d^4 ion compared to that of d^3 ion because e_g orbitals are pointed directly at the ligands. This

causes to a repulsion of ligands and an increase in the ionic radius of metal ion in octahedral field. In a weak field octahedral complex of d^5 ion, the last electron enters into the e_g orbitals which causes more repulsion of the ligands and further increase in ionic radius of metal ion in octahedral field. The electron density round the metal cation is spherically symmetric, therefore, this ion lies on the smooth line. Its ionic radius is smaller than that of d^0 system but larger than that of d^4 weak field system. The addition of electrons beyond the d^5 in a weak field octahedral complexes leads to a repetition of the same sequence, except that the d - orbitals now become doubly filled. The variation of ionic radii of dipositive metal ions of transition elements in weak field complexes as a function of atomic number is shown in Figure 4.17.

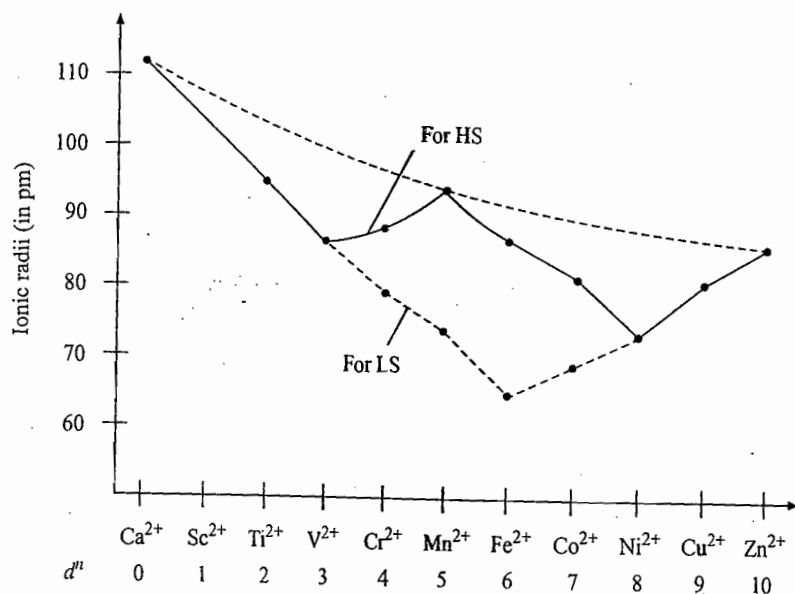

Figure 4.17.

For both dipositive and tripisitive ions of 3d-series transition elements, the ionic radii in strong octahedral field decreases until the t_{2g}^6 configuration is reached. The t_{2g} orbitals lie in the region between the ligands providing little or no screening of the nuclear charge. The increased nuclear charge causes the increase in force of attraction between metal cation and the ligands. In case of d^7 , d^8 , d^9 and d^{10} metal ions in strong field, the electrons are successively added to e_g orbitals. The first electron added to e_g orbitals cause an increase in relative ionic radius of d^7 ion compared to that of d^6 ion in strong field because e_g orbitals pointing directly at the ligands causes a repulsion of ligands. In the similar way ionic radii increase from d^7 to d^{10} metal ions in strong field. The variation of ionic radii of tripisitive metal ions of 3d-series transition elements is shown in weak and strong field complexes as a function of atomic number is shown in Figure 4.18.

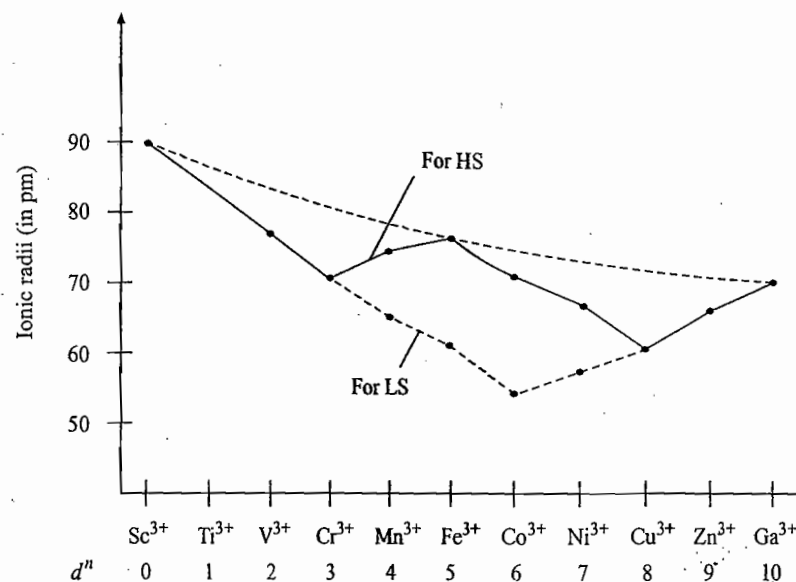

Figure 4.18.

(4) Structures of Spinel : Spinel is the mixed metal oxide having the formula $A^{(II)} B_2 O_4$ or $A^{(II)} B_2 O_3$. Where A can be a group 2 metal or a transition metal in +2 oxidation state and B can be a group 13 metal or a transition metal in +3 oxidation state. The oxide anions form a cubic close packed (ccp) or face centred cubic (fcc) lattice with four octahedral voids and eight tetrahedral voids per AB_2O_4 unit. One third of the metal ions occupy tetrahedral voids and two third occupy the octahedral voids. Tetrahedral voids are the double of the octahedral voids and octahedral voids are equal to the lattice points. Therefore,

$$\text{Number of tetrahedral voids} = 2 \times \text{Number of octahedral voids.}$$

$$\text{Number of octahedral voids} = \text{Number of lattice points.}$$

$$\begin{aligned} \text{Therefore, Number of tetrahedral voids} &= 2 \times \text{Number of octahedral voids.} \\ &= 2 \times \text{Number of lattice points.} \end{aligned}$$

Spinel is classified into two categories :

(a) Normal spinels (b) Inverse spinels

(a) Normal Spinel : In a normal spinel, A^{2+} ions occupy one eighth of the tetrahedral voids and B^{3+} ions occupy half of the octahedral voids. Thus, normal spinels can be written as $[A^{(II)}] [B_2^{(III)}] O_4$.

Examples of normal spinels are $MgAl_2O_4$, $MgCr_2O_4$, $NiCr_2O_4$, Mn_3O_4 , Co_3O_4 etc.

(b) Inverse Spinel : In an inverse spinel, half of the B^{3+} ions have exchanged places with all the A^{2+} ions. In other words, the A^{2+} ions occupy $\frac{1}{4}$ th of the octahedral voids along with half of the B^{3+} ions

whereas the other half of the B^{3+} ions occupy $\frac{1}{8}$ th of the tetrahedral voids. Inverse spinels can be

represented as $[\overset{(III)}{B}][\overset{(II)}{A} \overset{(III)}{B}]O_4$.

Examples of inverse spinels are : $CrFe_2O_4$, Fe_3O_4 , $NiFe_2O_4$, $MgFe_2O_4$, $NiAl_2O_4$ etc.

In general, the spinels having Fe^{3+} ions are inverse spinels.

Predicting the Structure of Spinel

An important factor in determining whether a spinel is normal or inverse is the CFSE of the cations occupying the tetrahedral and octahedral voids. The metal cations in tetrahedral and octahedral voids are surrounded by four and six oxide ions respectively. Thus, the metal cations occupying the tetrahedral and octahedral voids are considered to form tetrahedral and octahedral complexes respectively. The oxide ion behaves as a weak ligand. To determine whether a spinel is normal or inverse, we have to compare the CFSE in octahedral and tetrahedral environment for both A^{2+} and B^{3+} ions. If CFSE for B^{3+} ion in octahedral voids is greater than that of B^{3+} in tetrahedral and A^{2+} in both the tetrahedral and octahedral voids, the spinel will be normal.

If CFSE for A^{2+} ion in octahedral void is greater than A^{2+} in tetrahedral and B^{3+} in both the tetrahedral and octahedral voids, then the spinel will be inverse.

Examples :

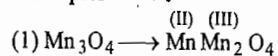

O^{2-} behaves as a weak ligand.

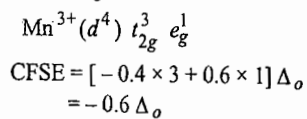
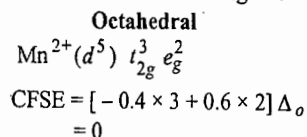

From these calculations it is observed that CFSE for Mn^{3+} in octahedral field is highest, therefore, it will be stabilized in octahedral voids. Thus, Mn^{3+} will occupy the octahedral voids and the Mn^{2+} ion will occupy the tetrahedral voids, and hence Mn_3O_4 is a normal spinel.

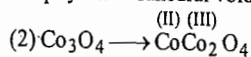

Co^{3+} is low spin in the field produced by oxide ions.

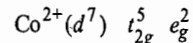
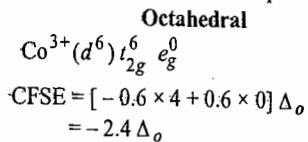

$$CFSE = [-0.4 \times 5 + 0.6 \times 2] \Delta_o$$

$$= -0.8 \Delta_o$$

Since CFSE for Co^{3+} is highest in octahedral field.

Therefore, Co^{3+} will occupy octahedral and Co^{2+} will occupy tetrahedral voids. Hence Co_3O_4 is a normal spinel.

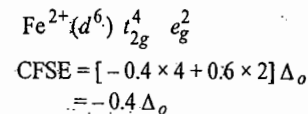
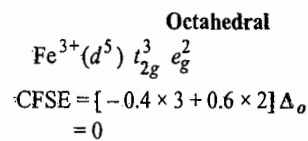
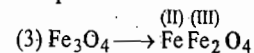

Since CFSE for Fe^{2+} in octahedral field is highest.

Therefore, Fe^{2+} ion will occupy octahedral voids and Fe^{3+} ions occupy tetrahedral voids and octahedral voids. Thus, Fe_3O_4 is an inverse spinel.

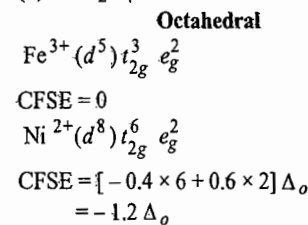

Since CFSE for Ni^{2+} ion is highest in octahedral field. Therefore, Ni^{2+} ion will occupy octahedral voids and Fe^{3+} will occupy both tetrahedral and octahedral voids. Thus, $NiFe_2O_4$ is an inverse spinel.

Most of the spinels having Fe^{3+} ions are inverse spinel. Fe^{3+} ion with d^5 configuration has CFSE equal to zero in both the octahedral and tetrahedral voids. A dipositive ion in the spinel will have greater CFSE in octahedral field than that in tetrahedral geometry because the crystal field splitting in tetrahedral geometry is 0.45 that of the equivalent octahedral environment. Thus, the dipositive ion will prefer to occupy the octahedral voids.

Note : If we calculate CFSE for A^{2+} and B^{3+} ions in only octahedral field, then it is concluded that if CFSE of B^{3+} is higher than that of A^{2+} , the spinel will be normal spinel. If CFSE of A^{2+} is higher than that of B^{3+} , then the spinel will be inverse spinel.

Limitations of Crystal Field Theory

Crystal field theory explain successfully the structures of complexes, magnetic properties, colour and electronic spectra, thermodynamic and kinetic aspects of the complexes. However, this theory has some serious limitations.

- (1) CFT considers only the metal d - orbitals and s - and p - orbitals are ignored.
- (2) This theory has not considered the covalent character in transition metal complexes.
- (3) CFT has also not considered the π -bonding (either the $M \rightarrow L$ or $L \rightarrow M$) in complexes.
- (4) CFT can not explain the relative strength of ligands as given in spectrochemical series.
- (5) The compounds like $\text{Cr}(\text{CO})_6$, $\text{Ni}(\text{CO})_4$ in which metal is in zero oxidation state and the ligand is neutral have no electrostatic attraction between the metal and the ligands.

Evidence for Metal Ligand Covalent Bonding in Complexes

- (1) $\text{Cr}(\text{CO})_6$ is a volatile compound and $\text{Ni}(\text{CO})_4$ is a liquid. This indicates that there is covalent bonding between metal and the ligands instead of the ionic. If there would be ionic bond, then $\text{Cr}(\text{CO})_6$ should be non-volatile and $\text{Ni}(\text{CO})_4$ solid.
- (2) **The Electron Spin Resonance (ESR) :** The ESR spectrum of $[\text{IrCl}_6]^{2-}$ suggests that the single unpaired electron is only 70% localized on the metal atom, and about 30% is localized on the chloride ion. This indicates that there is sharing of electron and hence some covalency between metal and ligands.
- (3) **The Nuclear Magnetic Resonance (NMR) :** The fluorine NMR has detected the delocalization of electron in the fluoro complexes, of paramagnetic metal ion. It is possible only when an unpaired electron spends more than negligible time on ^{19}F nucleus.
- (4) **The Nephelauxetic Effect :** The electronic repulsion in d - orbitals of transition metal cations give rise to a number of energy levels depending upon the arrangement of the electrons in d - orbitals. The energy difference between two energy states can be expressed in terms of interelectronic repulsion parameters, called the Racah parameters B and C. The difference in energy between two levels having same spin multiplicity can be expressed in terms of only B, and the difference in energy between two energy levels having different spin multiplicities can be expressed in terms of B and C. It is observed experimentally (*i.e.*, from electronic spectra of complexes) that the magnitude of B and C decreases when the complex is formed. The reduced value of B and C indicates that electron density is reduced on metal cation *i.e.*, electron cloud is delocalized over both the metal cation and the ligands. This suggests that there is some covalency between metal cation and the ligands. The more the value of B and C is reduced, the greater the delocalization of electron cloud and the greater the covalency. The delocalization of electron cloud over metal cation and the ligands is called the nephelauxetic effect.
- (5) **Nuclear Quadrupole Resonance (NQR) :** The NQR spectrum of some complexes containing halide ions as ligands like $[\text{PtCl}_4]^{2-}$, $[\text{PdCl}_4]^{2-}$ suggests that the metal-ligand bond is partly ionic and partly covalent.

Ligand Field Theory

Crystal field theory has treated ligands as point charged or dipoles and does not take into account the covalent bonding in complexes. Instead, it regards the bonding purely ionic. The physical measurements such as electron spin resonance (ESR) or electron paramagnetic resonance (EPR), nuclear magnetic resonance (NMR), nuclear quadrupole resonance (NQR) and Racah parameters calculations from electronic spectra give evidence in favour of covalent bonding in coordination compounds.

The covalent bonding in complexes has been explained by ligand field theory (LFT). According to ligand field theory, covalent bonds between metal and ligands are formed by the linear combinations of the metal atomic orbitals and ligand group orbitals (LGOs). The symmetries of ligand group orbitals must match the symmetries of the metal atomic orbitals such that there is positive overlapping of LGOs with metal orbitals along the bonding axes.

Sigma Bonding in Octahedral Complexes

In octahedral complexes, the ligands are approaching the metal cation on x -, y - and z - axes. Therefore, LGOs will overlap with metal orbital along the octahedral bonding axes to form σ -bonds. The metal cation has, in its valence shell, one ns , three np and five $(n-1)$ d - orbitals. The octahedral symmetry has transformed s -orbital into a_{1g} , p -orbitals into t_{1u} , d_{xy} , d_{yz} and d_{zx} orbitals into t_{2g} and $d_{x^2-y^2}$ and d_{z^2} orbitals into e_g sets.

Metal orbital	Symmetry
s	a_{1g}
p_x, p_y, p_z	t_{1u}
d_{xy}, d_{yz}, d_{zx}	t_{2g}
$d_{x^2-y^2}, d_{z^2}$	e_g

Since a_{1g} orbital is spherical in shape, therefore, it can overlap with LGOs on all axes. The t_{1u} and e_g orbitals are pointing along the axes. Therefore, these orbitals can form σ -bonds on octahedral axes by overlapping with LGOs. The t_{2g} orbitals lie in between the axes, therefore, these orbitals are not capable to overlap with LGOs to form σ -bonds. Therefore, out of the nine metal orbitals, only six (one a_{1g} , three t_{1u} and two e_g) orbitals participate in σ - bond formation. The t_{2g} orbitals are considered to be non-bonding molecular orbitals in octahedral complexes where there is no possibility of π -bonding. If the ligands have orbitals of same symmetry as that of metal t_{2g} orbitals, then t_{2g} metal orbitals will be involved in π - bonds.

Now the question arises that what are the LGOs and how can these be constructed? Each of the six equivalent ligand atoms contributes an atomic orbital or hybrid atomic orbital to form σ -bonds. In an octahedral complex, the six atomic or hybrid orbitals of the six ligands are pointing along $+x$, $-x$, $+y$, $-y$, $+z$ and $-z$ axes which have been represented as $\sigma_x, \sigma_{-x}, \sigma_y, \sigma_{-y}, \sigma_z$ and σ_{-z} respectively (Figure 4.19).

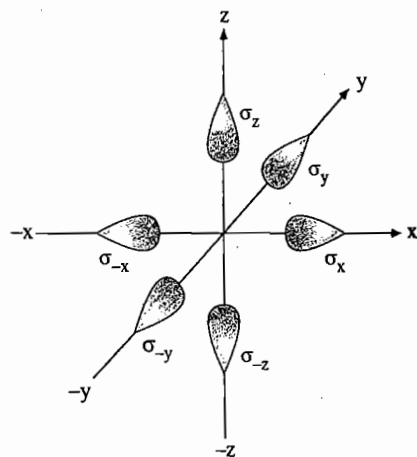

Figure 4.19 Six ligand orbitals in an octahedral system.

The $\sigma_x, \sigma_{-x}, \sigma_y, \sigma_{-y}, \sigma_z$ and σ_{-z} orbitals of ligands are combined together linearly to form a set of ligand group orbitals of the required symmetries to overlap with the a_{1g}, t_{1u} and e_g orbitals of metal.

Since the wave function of a_{1g} orbital has same sign, which is taken to be positive everywhere. The six ligands, therefore, can overlap equally with this orbital and each ligand orbital must also have positive sign. Thus, a_{1g} ligand group orbital can be constructed by an additive linear combination of the six ligand orbitals :

$$\Sigma_{a_{1g}} = \frac{1}{\sqrt{6}} (\sigma_x + \sigma_{-x} + \sigma_y + \sigma_{-y} + \sigma_z + \sigma_{-z}) \quad a_{1g}$$

Where $\frac{1}{\sqrt{6}}$ is a normalization constant and Σ and σ are the wavefunctions of LGO and contributing ligand orbitals.

Since wave function of one lobe of each of the p_x, p_y and p_z orbitals has positive sign and the other has negative sign. Therefore,

$$\Sigma_x = \frac{1}{\sqrt{2}} (\sigma_x - \sigma_{-x})$$

$$\Sigma_y = \frac{1}{\sqrt{2}} (\sigma_y - \sigma_{-y})$$

and

$$\Sigma_z = \frac{1}{\sqrt{2}} (\sigma_z - \sigma_{-z})$$

The two opposite lobes of $d_{x^2-y^2}$ orbitals have positive sign and the other two opposite lobes have negative sign. Therefore,

$$\Sigma_{x^2-y^2} = \frac{1}{2} (\sigma_x + \sigma_{-x} - \sigma_y - \sigma_{-y})$$

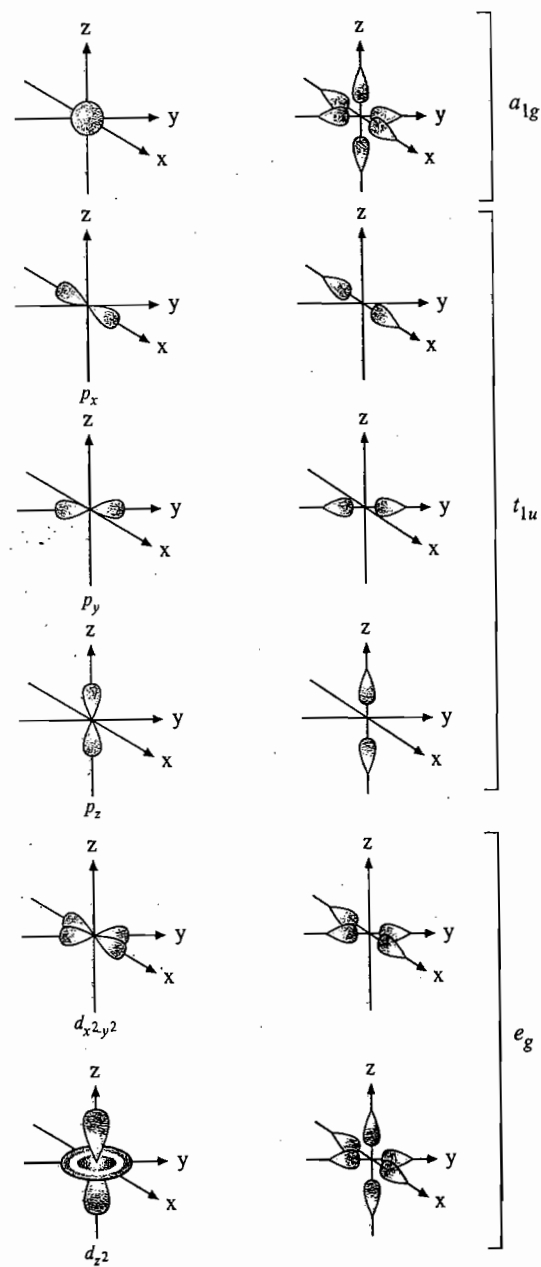

Figure 4.20.

The d_{z^2} orbital is obtained by the combination of two dependent orbitals viz. $d_{z^2-x^2}$ and $d_{z^2-y^2}$.

$$d_{z^2-x^2} + d_{z^2-y^2} = d_{z^2-x^2-y^2}$$

The d_{z^2} is actually the $d_{z^2-x^2-y^2}$. Therefore, the LGO that match the d_{z^2} orbital corresponds to the $d_{z^2-x^2-y^2}$.

$$\Sigma_{z^2} = \frac{1}{2\sqrt{3}}(2\sigma_z + 2\sigma_{-z} - \sigma_x - \sigma_{-x} - \sigma_y - \sigma_{-y})$$

The LGOs with their symmetry matched with metal orbitals are shown in Figure 4.20.

These six combinations account for all ligand orbitals to be of σ - symmetry. None of these LGOs have the symmetry of metal t_{2g} orbitals, therefore, the later do not participate in σ -bonding.

From the symmetry properties of octahedral complexes it is observed that metal and ligand a_{1g} orbitals will overlap to give two molecular orbitals (one bonding a_{1g} and one antibonding a_{1g}^*), the triply degenerate metal and ligand t_{1u} orbitals will overlap to give six molecular orbitals (three degenerate bonding, t_{1u} and three degenerate antibonding, t_{1u}^*), the doubly degenerate metal and ligand e_g orbitals will overlap to give four molecular orbitals (two degenerate bonding, e_g and two degenerate antibonding, e_g^*). Therefore, there are six bonding and six antibonding molecular orbitals. In the system without π -bonding, the three triply degenerate metal t_{2g} orbitals are non-bonding and have same energy as in free metal cation. The overlap of metal a_{1g} and t_{1u} orbitals with LGOs is more extensive than that of e_g orbitals, therefore, there are large differences in energy between the resulting a_{1g} and a_{1g}^* and t_{1u} and t_{1u}^* bonding and antibonding molecular orbitals. Therefore, the a_{1g} and t_{1u} bonding molecular orbitals are lowest in energy, and a_{1g}^* and t_{1u}^* antibonding molecular orbitals are of highest energy. The e_g and e_g^* molecular orbitals have less energy difference because of poorer overlap between the metal and ligand e_g orbitals. Therefore, we can say that more is the overlap, larger will be the separation and more will be covalent character.

The energy difference between t_{2g} and e_g^* molecular orbitals is equal to Δ_o as given by the crystal field theory.

It is assumed that a given molecular orbital has the character associated with the atomic orbital which is nearest in energy. For most of the ligands, the ligands σ - orbitals are derived from the atomic orbitals which have lower energies than the metal d -orbitals. Therefore, the six bonding molecular orbitals (one a_{1g} , three t_{1u} and two e_g orbitals) of the octahedral complex have primarily the character of ligand orbitals but also have some character of metal orbital from which they are derived. In fact, the ligand do leak on to the metal cation or atom. On the other hand, the antibonding molecular orbitals (e_g^* , a_{1g}^* and t_{1u}^*) have mainly the character of corresponding metal orbitals, but are somewhat delocalized on to the ligands. Since the t_{2g} orbitals are not involved in σ bonding, therefore, these are non-bonding and their energy is same as in free metal cation. These orbitals have pure metal d - orbitals character. In octahedral complexes, the six ligands provide six pairs of electrons which all are accommodated in the

bonding molecular orbitals. These electrons are mainly retained onto the ligands in the complex, just as describe by the CFT. In addition to the six pairs of electron provided by the ligands, there will always be d^n electrons available on metal atom or cation which occupy the non-bonding, t_{2g} and the antibonding e_g^* orbitals. The n electrons provided by the metal ion retain mainly onto the metal ion. The distribution of the metal d - electrons in t_{2g} and e_g^* orbitals are similar as described by the CFT but the basic difference is that in the LFT, the t_{2g} and e_g^* orbitals are not confined completely to the metal ion whereas in the CFT the d - electrons are completely confined to the metal ion.

In an octahedral complex, there are total $12 + d^n$ electrons to be placed in molecular orbitals, where d^n represents the number of metal d - electrons. The distribution of $12 + d^n$ electrons in molecular orbitals will be :

$$a_{1g}^2 t_{1u}^6 e_g^4 t_{2g}^p e_g^{*q} \quad (\text{where } p+q=n)$$

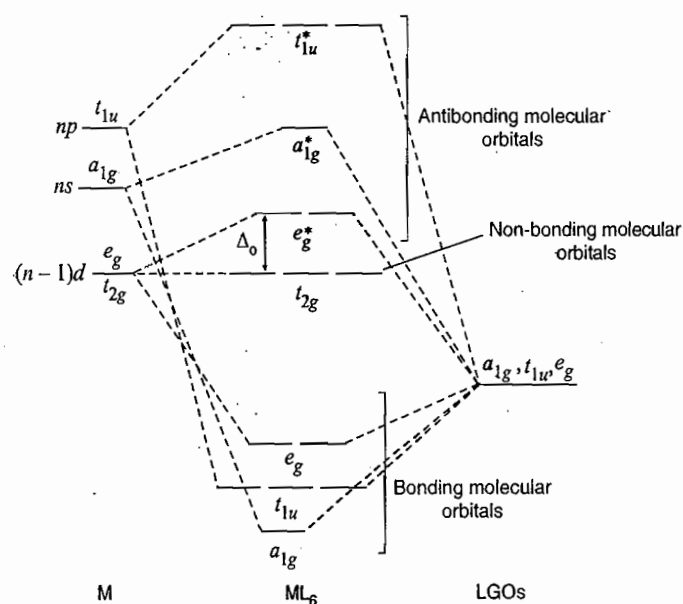

Figure 4.21 Molecular orbital diagram for σ -bonding in octahedral complexes.

The LFT also give the interpretation of high spin and low spin complexes depending on the magnitude of Δ_o and the pairing energy which is similar to that given by the CFT.

For low spin complexes, $\Delta_o > P$

For high spin complexes, $\Delta_o < P$

Order of Energies of Molecular Orbitals and Distribution of Electron in them :

- (a) For low spin complexes, the magnitude of Δ_o is large enough. Therefore, the energies of molecular orbitals follow the order :

$$a_{1g} < t_{1u} < e_g < t_{2g} < e_g^* < a_{1g}^* < t_{1u}^*$$

For example, the complex $[\text{Co}(\text{NH}_3)_6]^{3+}$ which is a low spin complex have total 18 valence electrons : 12 from the six NH_3 ligands and the six are metal d -electrons. The electronic configuration is :

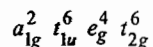

- (b) For high spin complexes, the magnitude of Δ_o is small, therefore, the energies of t_{2g} and e_g^* orbitals are assumed to be similar. Therefore, energies of molecular orbitals of high spin complexes follow the order :

$$a_{1g} < t_{1u} < e_g < t_{2g} < e_g^* < a_{1g}^* < t_{1u}^*$$

For example, for $[\text{CoF}_6]^{3-}$ complex ion, which is a high spin complex, there are total 18 electrons in valence shell. For this complex electronic distribution is :

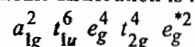

Figure 4.21 indicates that all octahedral complexes should have, in addition to the $d-d$ transitions, atleast one ligand to metal charge transfer band *i.e.*, transition of an electron from predominantly ligand orbitals to predominantly metal orbitals. The intense charge transfer bands are observed in UV or some times in visible region in many complexes corresponding to transitions of σ -electrons to vacant t_{2g} or e_g^* or both to higher energy orbitals.

π - Bonding in Octahedral Complexes

In addition to metal ligand σ interactions, many ligands which have orbitals with π -symmetry with respect to octahedral axes, are capable for π -bonding interaction with the metal atom or cation. The π -bonding will be significant if the metal and ligand orbital have proper π -symmetry, comparable size and energy. The metal and ligands orbitals involving in π -bonding are perpendicular to the M—L axis. In an octahedral complex, there are 12 ligand group orbitals capable of π -interactions. These LGOs belong to four symmetry classes : t_{1g} , t_{2g} , t_{1u} and t_{2u} . On the other hand, the transition metal cation in an octahedral complex has two types of orbitals (t_{1u} and t_{2g}) which are of correct symmetry for π -bonding. The t_{1g} and t_{2u} ligand group orbitals are non-bonding because there are no metal orbitals of these symmetries. The metal orbitals of t_{1u} symmetry are directed at the ligands and, therefore, involve in σ -bonding, therefore, these orbitals are unavailable for π -bonding. The t_{2g} ligand group orbitals and the metal orbitals of the same symmetry (*i.e.*, t_{2g}) can form metal-ligand π -molecular orbitals (*i.e.*, three bonding molecular orbitals t_{2g} and three antibonding molecular orbitals t_{2g}^*). The bonding molecular orbitals (t_{2g}) are of lower energy and the antibonding molecular orbitals (t_{2g}^*) are of higher energy than the atomic orbitals. Both bonding and antibonding molecular orbitals are triply degenerate.

In octahedral complexes the ligand group orbitals corresponding to t_{2g} symmetry may be $p\pi$, $d\pi$, π^* or σ^* . Therefore, there may be four types of π -interactions : (i) $d\pi - p\pi$ (ii) $d\pi - d\pi$ (iii) $d\pi - \pi^*$ and (iv) $d\pi - \sigma^*$.

(i) $d\pi - p\pi$ Bonding : In this type of π -bonding, the ligand group orbitals are formed by combinations of p -orbitals perpendicular to σ bond axes of donor atoms of ligands [Figure 4.22(a)]. The $d\pi - p\pi$ bonds are formed by donation of electrons from $p\pi$ -orbitals of ligands to empty $d\pi$ -orbitals of the metal. The $p\pi$ -orbitals are always filled and are found in F^- , Cl^- , Br^- , I^- , O^{2-} , RO^- , RS^- etc.

(ii) $d\pi - d\pi$ Bonding : In $d\pi - d\pi$ bonding the filled d -orbitals of metal overlap with the empty d -orbitals of the ligands [Figure 4.22(b)]. The ligands such as R_3P , R_2S , R_3As have the empty d -orbitals of π -symmetry.

(iii) $d\pi - \pi^*$ Bonding : The $d\pi - \pi^*$ bonds are formed when filled d -orbitals of metal cation or atom overlap with empty π^* (π -antibonding) of the ligands. The ligands having the empty π^* -orbitals are CO , CN^- , py , *o*-phenanthroline, ethylene, N_2 , NO_2^- etc.

(iv) $d\pi - \sigma^*$ Bonding : The $d\pi - \sigma^*$ bonds are formed when the filled d -orbitals of the metal cation overlap with the empty σ -antibonding (σ^*) of the ligands. The ligands having the empty σ^* orbitals are H_2 , R_3P , alkanes etc. In R_3P , the σ^* orbitals are of P—C bonds.

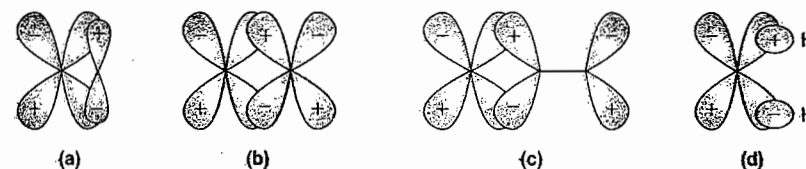

Figure 4.22 (a) $d\pi - p\pi$ bonding (b) $d\pi - d\pi$ bonding
(c) $d\pi - \pi^*$ bonding (d) $d\pi - \sigma^*$ bonding

If the ligand t_{2g} orbitals are filled and are of lower energy than partly filled metal t_{2g} orbitals, then the ligand t_{2g} orbitals overlaps with metal t_{2g} orbitals to give bonding t_{2g} molecular orbitals (*i.e.*, t_{2g}) of lower energy than LGOs and antibonding molecular orbitals (*i.e.*, t_{2g}^*) of higher energy relative to the non-bonding t_{2g} orbitals of σ -bonding complex. The ligands having filled t_{2g} LGOs of lower energy than the metal d -orbital are F^- , Cl^- , Br^- , I^- , H_2O , S^{2-} etc. These ligands having filled t_{2g} LGOs are called π -donor ligands. Since the LGOs are of lower energy than that metal t_{2g} orbitals, therefore, bonding molecular orbitals have the character of LGOs and the antibonding molecular orbitals have the character of metal t_{2g} orbitals. Therefore, the electrons supplied by the ligands t_{2g} orbitals will fill the π -bonding molecular orbitals and the electrons from the metal t_{2g} orbitals will fill the π -antibonding

orbitals. The e_g^* orbitals are not affected by π -bonding and t_{2g} metal orbitals becomes antibonding and hence are raised closer in energy to the metal e_g^* antibonding orbitals. Thus, the energy difference, Δ_o between t_{2g}^* and e_g^* decreases relative to the difference where metal ligand π -bonding does not exist. The lower Δ_o is smaller for OH^- ligands compared to H_2O because OH^- is a better π -donor.

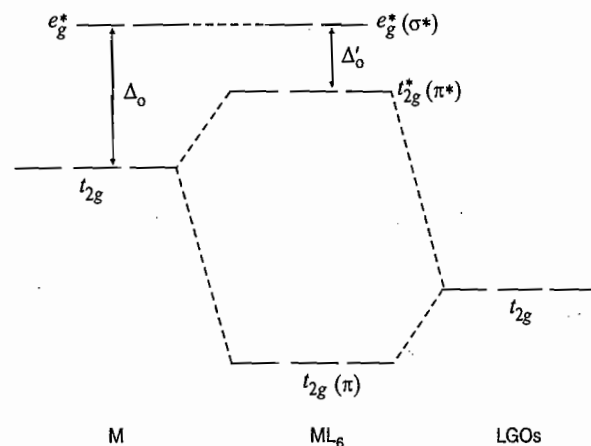

Figure 4.23

If the t_{2g} ligand orbitals are empty and of higher energy than the metal partly filled t_{2g} orbitals, then t_{2g} orbitals overlap with metal t_{2g} orbital to give bonding and antibonding molecular orbitals. i.e. ligands having empty t_{2g} orbitals of little higher energy than that of free metal cation are P , R_3As , R_2S (with vacant d -orbitals) and CO , CN^- , NO^+ , phen, N_2 (with vacant π^* orbitals) etc. of course these ligands with vacant π^* orbitals also have filled π -orbitals and can function as π -donor but because of very low energy these orbitals can not overlap with metal d -orbitals. These ligands with empty t_{2g} orbitals are called π -acceptor ligands. Since the LGOs have higher energy than that of metal orbitals, therefore, bonding molecular orbitals have the character of metal d -orbitals and the antibonding molecular orbitals have the character of LGOs. The resulting bonding orbitals are localized over both metal and ligands which were the non-bonding and localized on metal in the absence of π -bonding. Since the bonding molecular orbitals have the character of metal d -orbitals are raised in energy as compare to the t_{2g} orbitals in the absence of π -bonding. Therefore, energy difference Δ_o between t_{2g} bonding and e_g^* antibonding orbitals is increased relative to the difference

where M-L π -bonding does not exist. The energy of t_{2g}^* orbitals is also higher than that of e_g^* orbitals. Therefore, electron from metal d -orbitals are filled first in t_{2g} and then in e_g^* orbitals.

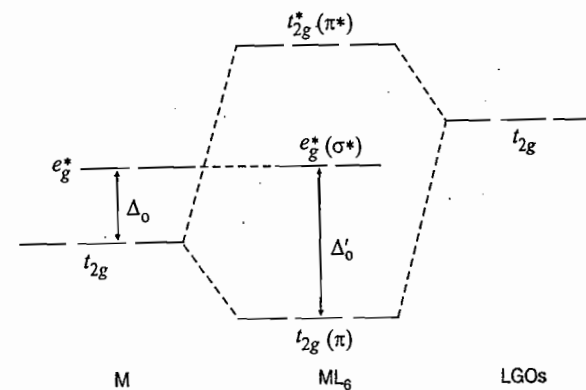
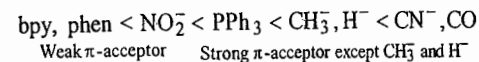
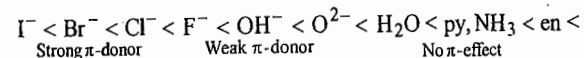

Figure 4.24

The ligand field theory explain the order of ligand in spectrochemical series from weaker to stronger. When π -bonding is significant, it has been observed that the ligands such as halides, S^{2-} , SCN^- which are strong π -donor decrease Δ_o and the π -acceptor ligands like CO , CN^- , R_3P , NO_2^- etc. which are strong π -acceptors increase Δ_o relative to the Δ_o where there is no π -bonding. Therefore, the strong π -donor ligands are at the weak end and the ligands which are strong π -acceptor lie at the strong end of the spectrochemical series. The ligands having little or no π -bonding ability have intermediate value of Δ_o and lie in the middle of the spectrochemical series. Thus, it has been concluded that the value of Δ_o increases in the order of: π -donor < weak π -donor < neither π -donor nor π -acceptor < weak π -acceptor < strong π -acceptors.



In the spectrochemical series the ligands CH_3^- and H^- ligands are neither π -donor nor strong π -acceptors, yet they are very high in spectrochemical series. The reason is that these are strong σ -donors.

Sigma Bonding in Tetrahedral Complexes

The procedure for the constitution of molecular orbital diagrams for tetrahedral and square planar complexes is same as that applied for octahedral complexes. The metal atom or ion in each case uses its

same nine valence orbitals available for bonding but their symmetry properties are different for each geometry. For a tetrahedral ML_4 complex, the metal s and p -orbitals have a_1 and t_2 symmetries respectively. The d_{xy} , d_{yz} and d_{zx} orbitals have t_2 and $d_{x^2-y^2}$ and d_{z^2} orbitals have e symmetry. It is seen that the symmetries of p -orbitals and that of d_{xy} , d_{yz} and d_{zx} orbitals are identical *i.e.*, t_2 symmetry. It is due to the fact that the p -orbitals hybridized with s -orbital (sp^3 -hybridization) and d_{xy} , d_{yz} and d_{zx} orbitals hybridized with s -orbital (sd^3 -hybridization) form tetrahedral geometry. Of the four ligand group orbitals (LGOs) constructed from ligand lone pair orbitals one have a_1 and three have t_2 symmetries. The a_1 orbital LGO interacts with a_1 orbital of metal to give one bonding and one antibonding MO and t_2 LGOs can interact with both sets of t_2 orbitals of metal (p and d_{xy} , d_{yz} , d_{zx}) to give one bonding and two antibonding molecular orbitals (Fig. 4.25). In contrast to the octahedral complexes, the metal e orbitals are non-bonding. The separation between the e and the next higher t_2 molecular orbitals is equal to Δ_t , as in CFT. For a complex such as $[CoCl_4]^{2-}$, there are total fifteen valence electrons of which eight electrons are produced by four ligands (two electrons per ligand) and the Co^{2+} (d^7) ion furnishes seven electrons. Eight electrons are filled in the bonding MOs (a_1 and t_2), four electrons in non-bonding e orbitals and three in the slightly antibonding t_2 orbitals.

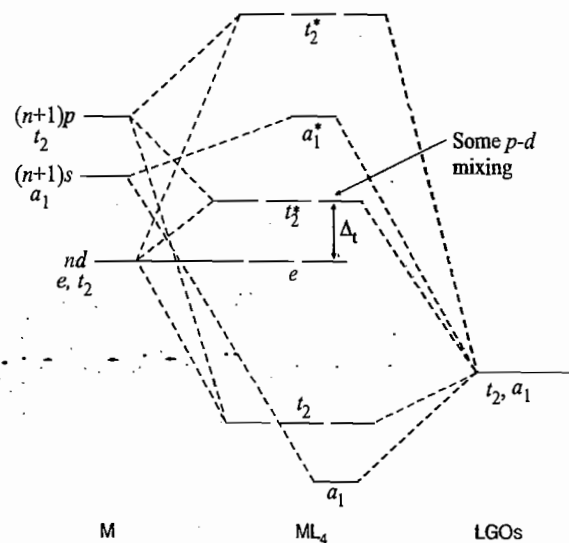

Fig. 4.25 MO diagram for σ -bonding in tetrahedral complexes.

Sigma Bonding in Square Planar Complexes

In square planar complexes, the d -orbitals have a_{1g} (d_{z^2}), e_g (d_{yz} , d_{zx}), b_{2g} (d_{xy}) and b_{1g} ($d_{x^2-y^2}$) symmetries.

The p -orbitals have a_{2u} (p_z) and e_u (p_x , p_y) symmetries. The four ligands lying along the x and y -axes give rise to ligand group orbitals of a_{1g} , b_{1g} and e_u symmetries. These LGOs interact with metal orbitals of same symmetry sigma molecular orbitals as shown in Fig. 4.26. The a_{1g} LGO interacts with both a_{1g} metal orbitals to form one bonding a_{1g} and one slightly antibonding and one antibonding molecular orbital. The metal orbitals b_{2g} , e_g and a_{2u} remain non-bonding because they have no symmetry similar to LGOs.

In general, the square planar complexes are formed by d^8 metal ions like Ni^{2+} (with strong ligands like CN^-), Pd^{2+} and Pt^{2+} ions. There are sixteen valence electrons, eight from the four ligands and eight from the metal ion. Eight electrons from ligands occupy the bonding molecular orbitals (a_{1g} , b_{1g} and e_u) and eight electrons from the metal ion occupy b_{2g} , e_g and a_{1g} (slightly antibonding) molecular orbitals and the complexes are diamagnetic. The square planar complexes are highly stable, though they contain 16 valence electrons. This is due to the reason that all the bonding MOs are filled and the antibonding MOs are empty. Adding additional electrons would destabilized the complex because the additional electrons would enter into the antibonding molecular orbitals and lower the bond order. The complexes containing electrons less than 16 are also less stable because they have lesser number of electrons in bonding molecular orbitals and lower the bond order.

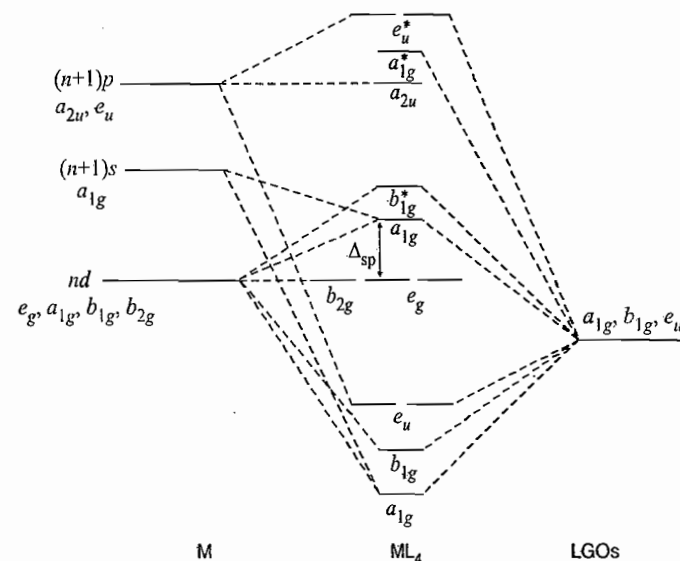

Fig. 4.26 Molecular diagram for σ -bonding in square planar complexes.

Crystal Field Splitting Diagrams for Trigonal bipyramidal, Square pyramidal and Pentagonal bipyramidal Complexes

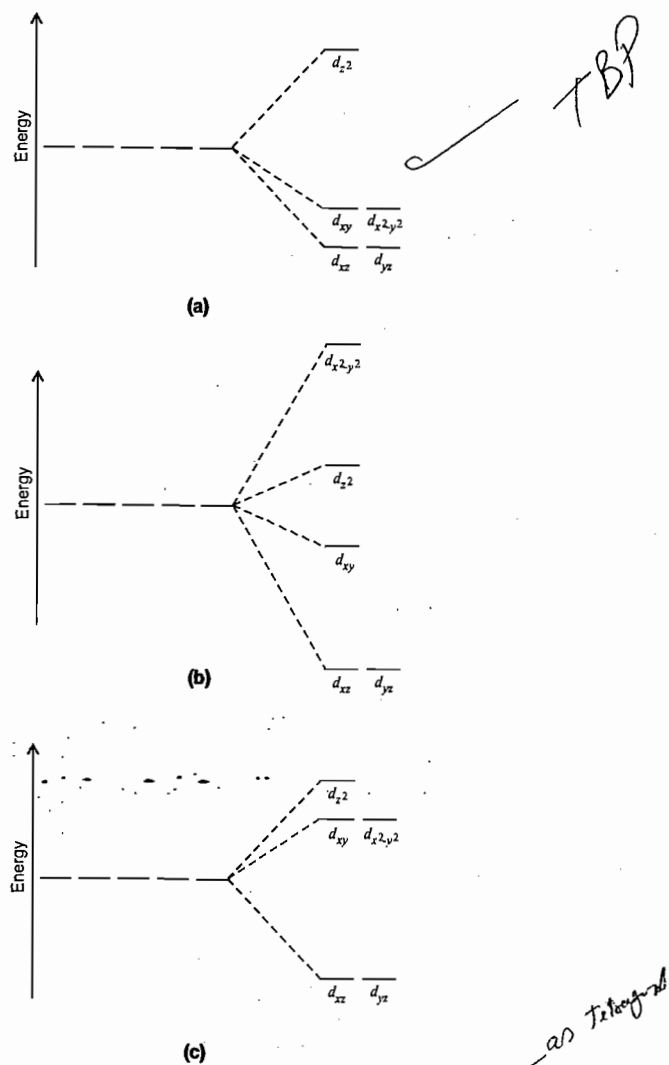

Figure 4.27 Crystal Field Splitting Diagrams for: (a) Trigonal bipyramidal, (b) Square pyramidal and (c) Pentagonal bipyramidal complexes.

Fill in the Blanks

- In CrF_2 , Cr(II) is octahedrally surrounded by six F^- ligands with two longer Cr—F bonds and four shorter ones because of
- The $[\text{FeX}_6]^{3-}$, where X^- is a monodentate ligand, has one unpaired electron. The X^- ligand produces a field.
- CN^- is a σ -donor as well as ligand.
- NH_3 is a donor ligand.
- The dipositive 3d-transition metals which lie on the line of hydration energy curve are
- $[\text{Fe}(\text{NH}_3)_6]^{2+}$ is unstable because NH_3 does not form with Fe^{2+} .
- The algebraic sum of all energy shifts of all orbitals should be
- The d -orbitals which participate in d^2sp^3 -hybridization are and
- The d -orbitals which participate in sd^3 -hybridization are
- The orbitals with highest energy in z-out and z-in distorted octahedral complexes are and respectively.
- The highest energy orbital in trigonal bipyramidal complex is
- The hybridization in $[\text{Cu}(\text{NH}_3)_4]^{2+}$ is sp^2d .
- According to CFT, the bond between metal cation and the ligands is
- Among the $[\text{Co}(\text{NH}_3)_6]^{3+}$, $[\text{Ir}(\text{NH}_3)_6]^{3+}$, $[\text{Fe}(\text{bpy})_3]^{3+}$ the Δ_o is highest for
- CN^- ligand causes strong splitting of d -orbitals in complexes because it is a good
- Cl^- ligand causes weak splitting of d -orbitals in complexes because it is a good
- The geometry of $[\text{NiCl}_4]^{2-}$ and $[\text{PtCl}_4]^{2-}$ are and respectively.

- [Ans. 1. Jahn-Teller distortion 2. strong
 3. π -acceptor 4. σ
 5. Mn^{2+} and Zn^{2+} 6. π -bond
 7. zero 8. $d_{x^2-y^2}$, d_{z^2}
 9. d_{xy} , d_{yz} , d_{zx} 10. $d_{x^2-y^2}$, d_{z^2}
 11. d_{z^2} 12. sp^2d
 13. ionic 14. $[\text{Ir}(\text{NH}_3)_6]^{3+}$
 15. π -acceptor 16. π -donor
 17. tetrahedral, square planar]

Objective Questions

- The crystal field stabilization energy (CFSE), in units of Δ_o for $[\text{CoF}_3(\text{H}_2\text{O})_3]$ is:
 - 0
 - 0.4
 - 0.8
 - 1.8
- For $\text{Ti}(\text{H}_2\text{O})_6^{3+}$, the absorption maximum due to $d-d$ transition is found at $20,000\text{ cm}^{-1}$. Therefore, the crystal field stabilization energy is:
 - $-20,000\text{ cm}^{-1}$
 - $\frac{4}{9} \times 20,000\text{ cm}^{-1}$
 - $8,000\text{ cm}^{-1}$
 - $-8,000\text{ cm}^{-1}$
- Which one of the following octahedral complexes will be distorted?
 - $[\text{Cr}(\text{H}_2\text{O})_6]^{2+}$
 - $[\text{Cr}(\text{H}_2\text{O})_6]^{3+}$
 - $[\text{Mn}(\text{H}_2\text{O})_6]^{2+}$
 - $[\text{Fe}(\text{H}_2\text{O})_6]^{3+}$
- The crystal field splitting energy (Δ) for CoCl_6^{4-} is 18000 cm^{-1} . The Δ for CoCl_4^{2-} would be:
 - 18000 cm^{-1}
 - 16000 cm^{-1}
 - 8000 cm^{-1}
 - 2000 cm^{-1}
- The crystal field stabilization energy (CFSE) will be the highest for:
 - CoF_6^{3-}
 - $\text{Co}(\text{CNS})_4^{2-}$
 - $\text{Mn}(\text{H}_2\text{O})_6^{2+}$
 - $\text{Co}(\text{NH}_3)_6^{3+}$
- Among $(\text{CH}_3)_3\text{P}$, NO^+ , CN^- and I_3^- ligands, the one which is not a π -acceptor ligand is:
 - I_3^-
 - CN^-
 - NO^+
 - $(\text{CH}_3)_3\text{P}$
- The complex with maximum CFSE is:
 - $[\text{CoCl}_4]^{2-}$
 - $[\text{Co}(\text{H}_2\text{O})_6]^{3+}$
 - $[\text{CoF}_3(\text{H}_2\text{O})_3]$
 - $[\text{CoF}_6]^{3-}$
- The compound which exhibits Jahn-Teller distortion is:
 - $[\text{Mn}(\text{H}_2\text{O})_6]^{2+}$
 - $[\text{Mn}(\text{H}_2\text{O})_6]^{3+}$
 - $[\text{Cr}(\text{H}_2\text{O})_6]^{3+}$
 - $[\text{Fe}(\text{CN})_6]^{4-}$
- The number of manganese ions in tetrahedral and octahedral sites, respectively in Mn_3O_4 are:
 - one Mn^{2+} and two Mn^{3+}
 - one Mn^{3+} and two Mn^{2+}
 - two Mn^{3+} and one Mn^{2+}
 - two Mn^{2+} and one Mn^{3+}
- The spinels CoFe_2O_4 and FeFe_2O_4 , respectively are:
 - inverse and inverse
 - inverse and normal
 - normal and normal
 - normal and inverse

- In the trigonal bipyramidal crystal field, the d -orbital with the highest energy is:
 - d_{xy}
 - $d_{x^2-y^2}$
 - d_{yz}
 - d_z^2
- The magnetic moment of the complex $\text{K}_3[\text{CoF}_6]$ is $5.0\mu_B$. The total stabilization energy will be:
 - $-0.4\Delta_o$
 - $-0.4\Delta_o + P$
 - $-2.4\Delta_o + 3P$
 - $-1.8\Delta_o + 3P$
- For the complex ion $[\text{Cu}(\text{NH}_3)_6]^{2+}$, the coordination geometry will be:
 - octahedral
 - tetragonally distorted octahedral
 - trigonal prismatic
 - trigonal antiprismatic
- The complex ion $[\text{Ni}(\text{CN})_4]^{2-}$ has square planar configuration with magnetic moment of zero. What would be the magnetic moment if it were tetrahedral?
 - 4.84 B.M.
 - 1.73 B.M.
 - 2.87 B.M.
 - 5.9 B.M.
- Arrange the following metal complex in order of their increasing hydration energy:

$[\text{Mn}(\text{H}_2\text{O})_6]^{2+}$	$[\text{V}(\text{H}_2\text{O})_6]^{2+}$	$[\text{Ni}(\text{H}_2\text{O})_6]^{2+}$	$[\text{Ti}(\text{H}_2\text{O})_6]^{2+}$
(P)	(Q)	(R)	(S)

 - $S < P < Q < R$
 - $P < Q < R < S$
 - $Q < P < R < S$
 - $S < R < Q < P$
- The structure of the complexes $\{\text{Cu}(\text{NH}_3)_4\}(\text{ClO}_4)_2$ and $[\text{Cu}(\text{NH}_3)_4](\text{ClO}_4)$ in solution respectively are:
 - square planar and tetrahedral
 - octahedral and square pyramidal
 - octahedral and trigonal bipyramidal
 - tetrahedral and square planar
- The correct statement about the Cu-N bond distance in $[\text{Cu}(\text{NH}_3)_6]^{2+}$ is:
 - all the bond distances are equal
 - the axial bonds are longer than the equatorial ones
 - the equatorial bonds are longer than the axial ones
 - all the bond distances are unequal
- The symmetry required for the ligand group orbitals (LGO) for the π -base ligands to have π -interactions with the metal d -orbitals in an octahedral geometry is:
 - a_{1g}
 - b_{2g}
 - e_g
 - t_{2g}
- Hybridization of Ni(II) in $\text{K}_2[\text{NiBr}_4]$ is:
 - dsp^2
 - sp^3
 - sp^2d
 - d^3s
- The CFSE for the following d^3 metal ions (V^{2+} , Cr^{3+} , Mo^{3+}) decreases in the following order:

- (a) $V^{2+} > Cr^{3+} > Mo^{3+}$ (b) $Cr^{3+} > V^{2+} > Mo^{3+}$ ✓ Rest
- (c) $Mo^{3+} > Cr^{3+} > V^{2+}$ (d) $Cr^{3+} > Mo^{3+} > V^{2+}$
21. Which one of the following complexes is Jahn-Teller distorted ?
- (a) $Co(NH_3)_6^{3+}$ (b) $Cr(H_2O)_6^{3+}$
- (c) $Cu(H_2O)_6^{2+}$ (d) $[Fe(CN)_6]^{4-}$
22. Which of the following shows NORMAL spinel structure ?
- (a) Fe_3O_4 (b) Mn_3O_4
- (c) $NiAl_2O_4$ (d) La_2CuO_4
23. On molecular orbital treatment of $[Mn(CO)_6]^{+}$, the symmetry of the LGO that is NOT sigma-bonding, is :
- (a) A_{1g} (b) T_{1g} ✓ To see
- (c) T_{1u} (d) E_g
24. CFSE of transition metal complexes can be determined by :
- (a) UV-visible spectroscopy (b) IR spectroscopy
- (c) Microwave spectroscopy (d) NMR spectroscopy
25. Which one of the following pairs of electronic configuration of high-spin transition metal ions (3d) in an octahedral field undergo a substantial Jahn-Teller distortion ?
- (a) d^3, d^9 (b) d^4, d^9
- (c) d^5, d^9 (d) d^6, d^9
26. Jahn-Teller distortion of $CuSO_4 \cdot 5H_2O$ acts to :
- (a) raise symmetry
- (b) remove an electronic degeneracy
- (c) cause loss of H_2O ligand
- (d) promote a d -electron to an antibonding molecular orbital
27. According to crystal field theory, Ni^{2+} can have two unpaired electron in :
- (a) octahedral geometry only (b) square-planar geometry only
- (c) tetrahedral geometry only (d) both octahedral and tetrahedral geometry
28. For the complexes : (A) $[Ni(H_2O)_6]^{2+}$ (B) $[Mn(H_2O)_6]^{2+}$ (C) $[Cr(H_2O)_6]^{3+}$ (D) $[Ti(H_2O)_6]^{3+}$, the ideal octahedral geometry will not be observed in :
- (a) (A) and (D) (b) (C) and (D)
- (c) (B) only (d) (D) only ✓
29. The enthalpies of hydration of Ca^{2+} , Mn^{2+} and Zn^{2+} follow the order :
- (a) $Mn^{2+} > Ca^{2+} > Zn^{2+}$
- (b) $Zn^{2+} > Ca^{2+} > Mn^{2+}$
- (c) $Mn^{2+} > Zn^{2+} > Ca^{2+}$
- (d) $Zn^{2+} > Mn^{2+} > Ca^{2+}$

30. The correct order of acidity among the following species is :
- (a) $[Na(H_2O)_6]^+ > [Ni(H_2O)_6]^{2+} > [Mn(H_2O)_6]^{2+} > [Sc(H_2O)_6]^{3+}$
- (b) $[Sc(H_2O)_6]^{3+} > [Ni(H_2O)_6]^{2+} > [Mn(H_2O)_6]^{2+} > [Na(H_2O)_6]^+$
- (c) $[Mn(H_2O)_6]^{2+} > [Ni(H_2O)_6]^{2+} > [Sc(H_2O)_6]^{3+} > [Na(H_2O)_6]^+$
- (d) $[Sc(H_2O)_6]^{3+} > [Na(H_2O)_6]^+ > [Ni(H_2O)_6]^{2+} > [Mn(H_2O)_6]^{2+}$
31. The correct order of d -orbital splitting in a trigonal bipyramidal geometry is :
- (a) $d_{z^2} > d_{xz} > d_{x^2-y^2}, d_{xy}$ (b) $d_{xz}, d_{yz} > d_{x^2-y^2}, d_{xy} > d_x^2$
- (c) $d_{x^2-y^2}, d_{xy} > d_{z^2} > d_{xz}, d_{yz}$ (d) $d_z^2 > d_{x^2-y^2}, d_{xy} > d_{xz}, d_{yz}$
32. As a ligand Cl^- is :
- (a) only a σ -donor (b) only a π -donor
- (c) both a σ -donor and a π -donor (d) a σ -donor and a σ -acceptor
33. Which of the following complexes has the highest number of unpaired electrons ?
- (a) $[FeCl_4]^-$ (b) $[VO(H_2O)_5]^{2+}$
- (c) $Hg[Co(NCS)_4]$ (d) $[Co(NH_3)_6]^{3+}$
34. Which is the correct statement about the Ni-N bond in $[Ni(NH_3)_6]^{2+}$?
- (a) All are of equal bond lengths
- (b) The two axial bonds are longer than the four equatorial bonds
- (c) The four equatorial bonds are longer than the two axial bonds
- (d) None of the bond length are equal
35. The observation of equal Cu-O distances in the hexa-coordinated Cu(II) complex, $K_2Pb[Cu(NO_2)_6]$ is best understood in terms of :
- (a) Failure of the Jahn-Teller theorem to predict the structure of this complex
- (b) Error in the crystallographic estimate of Cu-O distances
- (c) Dynamic Jahn-Teller distortion of the Cu-O bonds
- (d) Symmetrical distribution of the nine valence electrons of Cu(II)
36. It is known that pK_a of water is 15.7. Based on this water pK_a benchmark, arrange the following solvated metals-aqua ions in order of their increasing acidity :
- $Mn^{2+}(H_2O)_6, Fe^{3+}(H_2O)_6, Cu^{2+}(H_2O)_6, Ca^{2+}(H_2O)_8$.
- (a) All have same acidities
- (b) $Fe^{3+} < Cu^{2+} < Mn^{2+} < Ca^{2+}$
- (c) $Ca^{2+} < Cu^{2+} < Mn^{2+} < Fe^{3+}$
- (d) $Ca^{2+} < Mn^{2+} < Cu^{2+} < Fe^{3+}$
37. The pair of simple and inverse spinels respectively is :
- (a) Fe_3O_4 and Mn_3O_4 (b) Fe_3O_4 and Co_3O_4
- (c) Mn_3O_4 and $NiFe_2O_4$ (d) $NiFe_2O_4$ and Co_3O_4

38. Stabilisation of highest oxidation states of transition metals by strong electronegative ligands due to:
- (a) $d\pi(L) \rightarrow d\pi(M)$ bonding (b) $p\pi(L) \rightarrow d\pi(M)$ bonding
 (c) $d\pi(M) \rightarrow p\pi(L)$ bonding (d) $d\pi(M) \rightarrow d\pi(L)$ bonding
39. Which pair has zero CFSE?
- (a) Ca^{+2} , Mn^{+2} , Zn^{+2} (b) Ca^{+3} , Mn^{+3} , Zn^{+3}
 (c) Ca^{+2} , Cu^{+2} , Zn^{+2} (d) Ca^{+2} , Fe^{+3} , Zn^{+2}
40. The increasing order of crystal field splitting (Δ_o) is:
- (a) $\text{C}_5\text{H}_5\text{N} < \text{en} < \text{NO}_2^- < \text{Phen}$ (b) $\text{en} < \text{C}_5\text{H}_5\text{N} < \text{Phen} < \text{NO}_2^-$ *↑*
 (c) $\text{en} < \text{NO}_2^- < \text{C}_5\text{H}_5\text{N} < \text{Phen}$ (d) $\text{C}_5\text{H}_5\text{N} < \text{NO}_2^- < \text{en} < \text{Phen}$ *↑*
41. In the solid state, the CuCl_5^{3-} ion has two types of bonds. These are:
- (a) three long and two short (b) two long and three short
 (c) one long and four short (d) four long and one short
42. Identify the order representing increasing π -acidity of the following ligands: C_2F_4 , NEt_3 , CO and C_2H_4 .
- (a) $\text{CO} < \text{C}_2\text{F}_4 < \text{C}_2\text{H}_4 < \text{NEt}_3$ (b) $\text{C}_2\text{F}_4 < \text{C}_2\text{H}_4 < \text{NEt}_3 < \text{CO}$
 (c) $\text{C}_2\text{H}_4 < \text{NEt}_3 < \text{CO} < \text{C}_2\text{F}_4$ (d) $\text{NEt}_3 < \text{C}_2\text{H}_4 < \text{C}_2\text{F}_4 < \text{CO}$
43. The correct spinel structure of Co_3O_4 is:
- (a) $(\text{Co}^{2+})_t (\text{2Co}^{3+})_o \text{O}_4$ (b) $(\text{Co}^{2+})_t (\text{2Co}^{3+}\text{Co}^{3+})_o \text{O}_4$
 (c) $(\text{Co}^{2+}\text{Co}^{3+})_t (\text{Co}^{3+})_o \text{O}_4$ (d) $(\text{2Co}^{3+})_t (\text{Co}^{2+})_o \text{O}_4$

ANSWERS

- | | | | | | | |
|---------|---------|---------|---------|---------|---------|---------|
| 1. (b) | 2. (d) | 3. (a) | 4. (c) | 5. (d) | 6. (a) | 7. (b) |
| 8. (b) | 9. (a) | 10. (a) | 11. (d) | 12. (a) | 13. (b) | 14. (c) |
| 15. (a) | 16. (a) | 17. (b) | 18. (d) | 19. (b) | 20. (c) | 21. (c) |
| 22. (b) | 23. (b) | 24. (a) | 25. (b) | 26. (b) | 27. (d) | 28. (d) |
| 29. (d) | 30. (b) | 31. (d) | 32. (c) | 33. (a) | 34. (a) | 35. (c) |
| 36. (d) | 37. (c) | 38. (b) | 39. (a) | 40. (b) | 41. (a) | 42. (d) |
| 43. (a) | | | | | | |

Subjective Questions

- Pt^{4+} ion forms octahedral whereas Pt^{2+} forms square planar complexes. Explain.
- Pt(II) makes square planar complexes almost exclusively. Explain with the help of crystal field theory.
- What is the effect of π -donor and π -acceptor ligands on Δ_o ? Explain on the basis of ligand field theory.

- Crystal field splitting energy Δ_o for $[\text{Cr}(\text{NH}_3)_6]^{2+}$ is $10,200 \text{ cm}^{-1}$ while for $[\text{Cr}(\text{NH}_3)_4]^{2+}$ is $5,900 \text{ cm}^{-1}$. Explain.
- Draw the crystal field splitting diagram for $[\text{CoCl}_4]^{2-}$ and calculate CFSE.
- Determine the CFSE of a d^6 -complex having $10 \text{ Dq} = 25,000 \text{ cm}^{-1}$ and $P = 15,000 \text{ cm}^{-1}$ (mean pairing energy).
- Which complex in each of the following pairs will have greater crystal field splitting and why?
 - $[\text{Co}(\text{en})_3]^{3+}$ or $[\text{Rh}(\text{en})_3]^{3+}$
 - $[\text{Cr}(\text{CN})_6]^{3-}$ or $[\text{Cr}(\text{NH}_3)_6]^{3+}$
 - $[\text{Fe}(\text{CN})_6]^{3-}$ or $[\text{Ru}(\text{CN})_6]^{3-}$
 - $[\text{Fe}(\text{H}_2\text{O})_6]^{3+}$ or $[\text{Fe}(\text{CN})_6]^{3-}$
 - $[\text{Co}(\text{NO}_2)_6]^{3-}$ or $[\text{Co}(\text{ONO})_6]^{3-}$
- Tetrahedral complexes are high spin. Explain.
- Explain the variation of lattice energies of the divalent 3d-series transition metal halides.
- $\text{K}_2[\text{NiF}_6]$ is diamagnetic while $\text{K}_3[\text{CoF}_6]$ is paramagnetic. Both have same d-configuration. Explain on the basis of CFT.
- For a complex ion $[\text{MnL}_6]^{2+}$, where L is a neutral mono-dentate ligand, the mean pairing energy (P) is found to be $28,000 \text{ cm}^{-1}$. If the magnitude of Δ_o is $21,000 \text{ cm}^{-1}$, calculate CFSE.
- $\text{K}_4[\text{Cr}(\text{NCS})_6]$ has a magnetic moment of 5.0 B.M. while $\text{K}_4[\text{Cr}(\text{CN})_6]$ has a value of only 3.2 B.M. Give the geometry of each complex on the basis of VBT.
- Define Jahn-Teller theorem. Giving reason, explain in which case this effect would be observed?

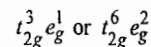

- On the basis of VBT, account for the magnetic properties of:
 - $[\text{Ni}(\text{NH}_3)_6]^{2+}$
 - $[\text{Co}(\text{NH}_3)_6]^{2+}$
 - $[\text{Fe}(\text{CN})_6]^{4-}$
 - $[\text{Cr}(\text{CN})_6]^{4-}$
 - $[\text{Co}(\text{NH}_3)_6]^{3+}$
- In the crystal of CuF_2 , Cu^{2+} ion is surrounded by six F^- with four F^- at a distance of 193 pm while two F^- at 227 pm. Explain.
- For tetrahedral complexes, $\Delta_t = \frac{4}{9} \Delta_o$. Explain.
- The magnetic moment of $[\text{MnBr}_4]^{2-}$ and $[\text{Mn}(\text{CN})_6]^{3-}$ are 5.9 and 2.9 B.M. respectively. Using VBT, assign the geometries of these complexes.
- Cobalt(II) is easily oxidized to cobalt(III) in the presence of strong field ligands but the isoelectronic nickel(III) complexes are oxidizing agent. Explain on the basis of CFT.

19. Solid CrF_3 contains a Cr(III) ion surrounded by six F^- ions in an octahedral geometry, all the Cr—F distances are 190 pm. However, MnF_3 is in a tetragonal distorted geometry with Mn—F distances of 179, 191 and 209 pm (two of each). Explain.
20. F^- is a weak ligand whereas CN^- is a strong. Explain on the basis of LFT.
21. $4d$ and $5d$ -series transition elements form low spin complexes. Explain.
22. The enthalpy of hydration of Cr^{2+} is $-460 \text{ kcal mol}^{-1}$. In the presence of CFSE, the value of ΔH would be $-435 \text{ kcal mol}^{-1}$. Estimate the value of Δ_o for $[\text{Cr}(\text{H}_2\text{O})_6]^{2+}$.
23. The magnetic moment of $[\text{Fe}(\text{H}_2\text{O})_6]^{3+}$ was found to be 5.9 B.M. and of $[\text{Fe}(\text{CN})_6]^{3-}$ is 1.9 B.M. Account for the above observation on the basis of VBT.
24. The $[\text{Ni}(\text{CN})_4]^{2-}$ ion is square planar and diamagnetic whereas $[\text{NiCl}_4]^{2-}$ is tetrahedral and paramagnetic. Explain.
25. Which is more stable and which one is more labile in aqueous solution, Cr^{3+} or Mn^{3+} ? Explain.
26. Weak ligands form high spin complexes whereas strong ligands form low spin complexes with $3d$ -transition metal ions. Explain.
27. Square planar geometry is especially common for d^8 -configuration. Explain.

□□□

 d^3 d^5 

5

Colour and Electronic Spectra

Electromagnetic radiations of white light (such as sun light) consist of a continuous spectrum of wavelengths or wave numbers corresponding to different colours. If a compound absorbs light (photon) of one colour, (say orange), then it reflects (or transmits) light of blue colour. The transmitted (or reflected) light of blue colour attacks on the retina of our eyes and the compound is seen to be blue coloured. The colour of transmitted light is called complementary colour of absorbed light. A compound appears blue if it absorbs radiations of all colours but reflects blue colour *i.e.*, it absorbs radiations of white light minus blue colour. A compound also looks blue if it reflects all colours except orange, the complementary colour of blue. A compound appears black if it absorbs all the radiations of white light in visible region. If a compound absorbs no visible light, it appears white or colourless. Most of the transition metal complexes show variety of colours that depend on the nature of metal and the ligands. For example, $[\text{Ti}(\text{H}_2\text{O})_6]^{3+}$ is purple, $[\text{Co}(\text{H}_2\text{O})_6]^{2+}$ is pink, $[\text{Cu}(\text{H}_2\text{O})_6]^{2+}$ is blue, $[\text{Cr}(\text{H}_2\text{O})_6]^{3+}$ is violet, $[\text{Cr}(\text{H}_2\text{O})_6]^{2+}$ is blue, $[\text{CoCl}_4]^{2-}$ is blue, $[\text{Ni}(\text{H}_2\text{O})_6]^{2+}$ is green, $[\text{Ni}(\text{NH}_3)_6]^{2+}$ is blue, $[\text{Ni}(\text{en})_3]^{2+}$ is violet. When ammonia is added to $[\text{Ni}(\text{H}_2\text{O})_6]^{2+}$, the green colour is changed to blue due to the formation of $[\text{Ni}(\text{NH}_3)_6]^{2+}$. When ethylenediamine is added to $[\text{Ni}(\text{H}_2\text{O})_6]^{2+}$ or $[\text{Ni}(\text{NH}_3)_6]^{2+}$ green and blue colours change to violet due to the formation of $[\text{Ni}(\text{en})_3]^{2+}$.

Using an artist's colour wheel Figure 5.1, it can be determined the observed colour of a compound from the colour of absorbed light. Complementary colours are shown on opposite sides of the colour wheel. The colours of absorbed and reflected light are complimentary to each other.

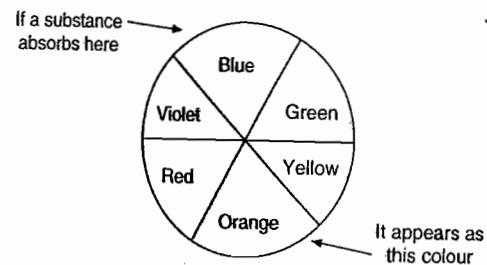

Figure 5.1 Artist's colour wheel.

The colour of a compound arises due to the electronic transition from ground state (lowest energy state) to the excited state (higher energy state) as shown in Figure 5.2. When a photon having energy equal to the difference between the ground state and the excited state strikes the compound (or ion), the electron present in ground state gets promoted to the excited state. The promotion (or excitation) of an electron from ground state to the excited state is called electronic transition. In complexes the electronic transitions take place from t_{2g} to e_g or e to t_2 orbitals in octahedral or tetrahedral complexes and such type of transitions are called $d-d$ transitions.

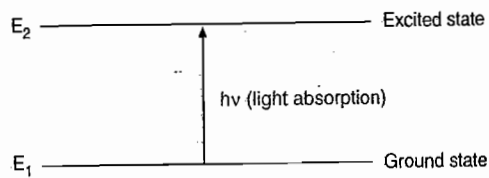

Figure 5.2

If the electromagnetic radiations absorbed by a compound lie in UV or IR region, then the transmitted (or reflected) light will lie in UV or IR region and the compound appears colourless.

The energy of absorbed light depends on the spacing between ground and excited states. The energy of separation between two states is given by :

$$\Delta E = E_2 - E_1 = hv = \frac{hc}{\lambda} = hc\bar{\nu} \quad (\because \bar{\nu} = \frac{1}{\lambda})$$

where,

ΔE = energy

h = Planck constant = 6.63×10^{-34} J.s

c = velocity of light = 10^{10} cm s⁻¹

λ = wavelength of light absorbed (cm)

ν = frequency of light absorbed (s⁻¹)

$\bar{\nu}$ = wave number (cm⁻¹) = $\frac{1}{\lambda}$

In some complexes the Δ value is very small and these absorb light radiations in infrared region and thus appear colourless because infrared radiations are colourless.

In the same way, some complexes have large Δ value (large energy difference between ground state and excited state) and absorb light radiations in UV region and thus appears colourless.

The magnitude of crystal field splitting (Δ) can be measured with the help of wavelength of light absorbed. The measure of the amount of light absorbed by a compound is called the absorbance (log ϵ) and a plot of absorbance versus wavelength or wave number, $\bar{\nu}$ is called an absorption spectrum. The best example for the measurement of magnitude of Δ is $[\text{Ti}(\text{H}_2\text{O})_6]^{3+}$ because Ti^{3+} ion has only one electron in $3d$ -orbital and it gives only one peak in its electronic spectrum. The colour of $[\text{Ti}(\text{H}_2\text{O})_6]^{3+}$ ion is purple. In this complex ion, the electron occupies the orbital of the lowest energy i.e., any one of the degenerate t_{2g} orbitals. The purple colour of $[\text{Ti}(\text{H}_2\text{O})_6]^{3+}$ ion is due to absorption of blue-green light and transition of electron of the t_{2g} orbitals to one of the degenerate e_g orbitals. The absorption

spectrum of $[\text{Ti}(\text{H}_2\text{O})_6]^{3+}$ reveals that the $d-d$ transition occurs with a single broad peak with a maximum absorption at 20300 cm^{-1} (wavelength of 498 nm) which corresponds to 243 kJ mol^{-1} energy (Figure 5.3).

Since $1 \text{ kJ mol}^{-1} = 83.7 \text{ cm}^{-1}$

$$\text{Thus, } \Delta_o \text{ for } [\text{Ti}(\text{H}_2\text{O})_6]^{3+} = \frac{20300}{83.7} \approx 242.53 \text{ kJ mol}^{-1}.$$

The d^1 case is one of the simplest case because energy of absorbed light is equal to the magnitude of Δ_o , for other d^n electronic configuration, the electron-electron interactions must be taken into account and more calculations are involved for determination of Δ_o value.

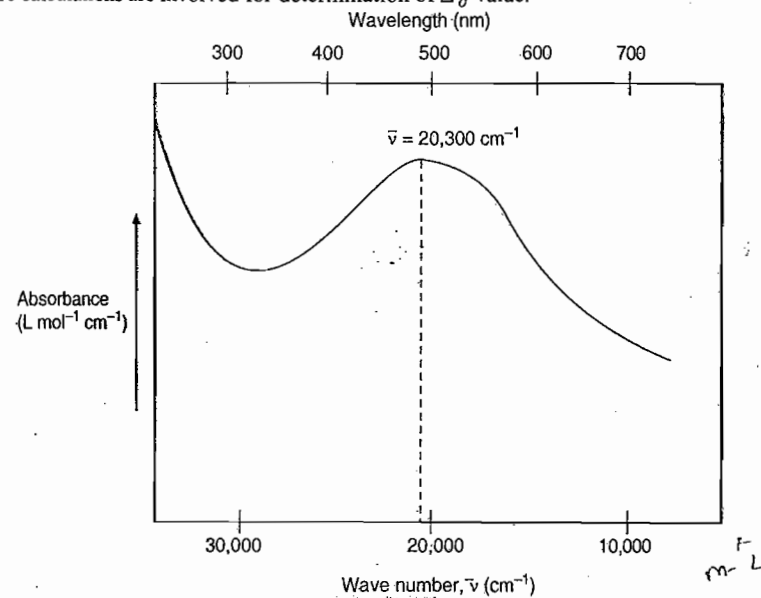

Figure 5.3

Most of the complexes of transition elements give broad absorption bands extending over several thousand wave numbers. In transition metal complexes the M-L bonds are not rigid. When light is absorbed by a transition metal complex electronic transitions and vibrations occur simultaneously which are called vibronic transitions. Due to vibrations of ligands energy of d -electrons changes. When a ligand moves towards the transition metal the value of Δ_o increases and when a ligand moves away from the transition metal energy of d -electrons increases. According to Frank Condon principle*, during one vibration, a large numbers of electronic transitions over several thousand wave numbers occur. The two additional factors which are responsible for broad bands are spin-orbit coupling and Jahn-Teller distortion.

Sharp peaks are observed in complexes where Δ_o does not change or energy of ground state and excited state changes equally. Sharp peaks are observed for high spin Mn^{2+} complexes.

* Frank Condon principle states that electronic transitions are much faster than atomic vibrations.

In most of the lanthanoid complexes sharp bands are observed in absorption spectra. The f -orbitals are buried deep and there is no interaction of ligands with f -orbitals. Any vibration of ligands or change in nature of ligands does not change the energy of f -electrons and magnitude of Δ will remain unaffected.

Table 5.1 Colours of Absorbed Light and Complementary Colours

Wavelength Range (in Å)	Range of Wave Numbers (in cm^{-1})	Colour of Absorbed Light	Complementary Colour i.e. Colour of Transmitted Light
< 4000	> 25000	Colourless (UV)	Colourless
4000-4500	22000-25000	Violet	Yellow
4500-4900	20000-22000	Blue	Orange
4900-5500	18000-20000	Green	Red
5500-5800	17000-18000	Yellow	Violet
5800-6500	15000-17000	Orange	Blue
6500-7500	14000-15000	Red	Green
> 7500	< 14000	Colourless (Infrared)	Colourless

1 nm = 10 Å

Beer-Lambert Law

When a light of intensity I_0 of a given wave number ($\bar{\nu}$) or wavelength passes through a solution, the light transmits with intensity I which is lower than the intensity of the incident light (I_0). According to Beer-Lambert law, absorbance of the solution is given by:

$$A = \log \frac{I_0}{I} = \epsilon l c$$

where, A = absorbance

ϵ = molar absorptivity or molar absorption coefficient ($\text{L mol}^{-1} \text{cm}^{-1}$)

l = path length (cm)

c = concentration of solution (mol L^{-1})

Absorbance is a dimensionless quantity.

A plot of absorbance versus wavelength or wave number is called absorption spectrum.

THE ANGULAR MOMENTUM OF AN ELECTRON

Orbital Angular Momentum

An electron moving in its orbital round the nucleus possesses an angular momentum which is called orbital angular momentum. A measure of orbital angular momentum (l) is given by l values corresponding to the orbital.

$$\text{Orbital angular momentum } (l) = \sqrt{l(l+1)} \cdot \frac{h}{2\pi}$$

where l = orbital angular momentum quantum number.

h = Planck constant = 6.63×10^{-34} J.s

Angular momentum is a vector quantity.

Angular momentum is a vector quantity.

l is always zero or positive value and hence so l .

The angular momentum vector (l) provides $(2l+1)$ orientations in space about any given reference direction (generally vertical z-axis) in such a manner that its components along the reference direction are integral multiples of $h/2\pi$ as shown in Figure 5.4 for $l=2$. The component of l in reference direction is represented as l_z . Since l_z are integral multiples of $\frac{h}{2\pi}$, the components can be represented in terms of an integral number l_z . l_z is the magnetic quantum number, m_l .

$$l_z = l_z \cdot \frac{h}{2\pi}$$

For $l=1$, $m_l = +1, 0, -1$

For $l=2$, $m_l = +2, +1, 0, -1, -2$

In general, $m_l = l, l-1, \dots, 0, \dots, -(l-1), -l$

The orbitals corresponding to $2l+1$ values are degenerate because energy of an electron depends only on the magnitude but not on the direction of angular momentum.

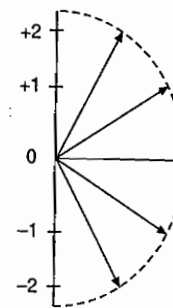

Figure 5.4

2. Electron Spin Angular Momentum

An electron in atom is not only moving about the nucleus but also is spinning about its own axis. The spinning motion of an electron generates an angular momentum, called as spin angular momentum (s) which is also a vector quantity.

$$\text{Spin angular momentum } (s) = \sqrt{s(s+1)} \cdot \frac{h}{2\pi}$$

where

s = spin quantum number.

The spin angular momentum (s) provides $(2s+1)$ i.e. two orientations about the reference direction (i.e. z-axis) in such a manner that its components along the reference direction are half integral multiples of $h/2\pi$ (Figure 5.5). The component of s along the reference direction can be represented in terms of s_z or m_s . The values of s_z

are $+\frac{1}{2}$ or $-\frac{1}{2}$ only.

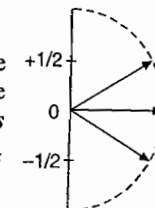

Figure 5.5

3. Spin-Orbit Coupling

The interaction of orbital angular momentum with spin angular momentum is called **spin-orbit coupling**. The strength of coupling and its effect on energy levels of the atom depend on the orientations of orbital and spin angular momenta.

4. Total Angular Momentum

It is the vector sum of orbital angular momentum and spin angular momentum. When the orbital angular momentum and spin angular momentum are parallel, the total angular momentum is high and when the two angular momenta are opposite to one another, the total angular momentum is low.

∴ Total angular momentum (j) = $l + s$

$$j = l + \frac{1}{2} \text{ (when two angular momenta are parallel)}$$

$$j = l - \frac{1}{2} \text{ (when two angular momenta are in opposite directions)}$$

In other words, we can say that j is half integral, since s is half integral for one electron atom.

j can also be expressed in terms of total angular momentum quantum number (j).

$$j = \sqrt{j(j+1)} \cdot \frac{h}{2\pi}$$

THE TOTAL ANGULAR MOMENTUM OF MANY ELECTRONS ATOMS

1. The Total Orbital Angular Momentum

When two or more electrons are present in a subshell of an atom, their individual orbital angular momenta may add together or oppose each other. The total orbital angular momentum (L) is given by:

$$L = \sqrt{L(L+1)} \cdot \frac{h}{2\pi}$$

where

L = total orbital angular momentum quantum number (a non-negative integer)

If there are two electrons in a subshell with orbital angular momentum quantum numbers l_1 and l_2 respectively. The value of L is obtained by coupling the individual orbital angular momentum quantum numbers by using the Clebsch-Gordan series.

$$L = l_1 + l_2, l_1 + l_2 - 1, \dots, |l_1 - l_2|$$

Since L is non-negative, so modulus sign is used. If two orbital angular momenta are parallel, then $L (= l_1 + l_2)$ is maximum. If two orbital angular momenta are opposed, then $L (= |l_1 - l_2|)$ is minimum. The intermediate values represent possible intermediate relative orientations of the two momenta. For d^2 electrons $l_1 = l_2 = 2$

$$L = 2 + 2, 2 + 2 - 1, \dots, |2 - 2| \\ = 4, 3, 2, 1, 0$$

For the quantum numbers $L=0, 1, 2, 3, \dots$ the terms S, P, D, F, \dots are used which are parallel to the l values for s, p, d, f, \dots orbitals.

For $L =$	0	1	2	3	4	5	6	7
Terms	S	P	D	F	G	H	I	K

Orbitals angular momentum has $2L + 1$ orientations distinguished by the quantum number M_L .

$$M_L = L, L-1, L-2, \dots, 0, \dots, -L$$

A closed shell has zero orbital angular momentum because the sum of individual orbital angular momenta is zero.

2. The Total Spin Angular Momentum

When two or more electrons are present in a subshell of an atom. The total spin angular momentum (S) is given by :

$$S = \sqrt{S(S+1)} \cdot \frac{h}{2\pi}$$

where

S = total spin angular momentum quantum number.

S is either non-negative integer or zero only if number of electrons is even or half integer if number of electrons is odd.

The values of S can be obtained by using the Clebsch-Gordan series. If there are two electrons with spin quantum numbers s_1 and s_2 then

$$S = s_1 + s_2, s_1 + s_2 - 1, \dots, |s_1 - s_2|$$

Modulus sign is used because S is a non-negative integer or half integer.

For each electron $s = \frac{1}{2}$

∴ $S = 1, 0$ (For two electrons)

$$S = \frac{N}{2}, \frac{N}{2} - 1, \dots, \frac{1}{2} \text{ [If no. of electrons (N) is odd]}$$

$$S = \frac{N}{2}, \frac{N}{2} - 1, \dots, 0 \text{ [If no. of electrons (N) is even]}$$

The spin multiplicity of term is $2S + 1$.

3. Spin-Orbit Coupling

If there are two or more electrons in a subshell, there is coupling of all the spins and all the orbital angular momenta. There are two different ways in which the coupling of spin and orbital angular momenta take place.

(i) L-S Coupling or Russel-Saunders Coupling

L - S coupling occurs in atoms of low atomic numbers because in these atoms spin-orbit coupling is weak. First sum the orbital angular momentum to give a total L and then spin angular momenta to give a total S separately and finally add these two momenta to give the total angular momentum (J).

$$L = \sum l_i, \quad S = \sum s_i \\ J = L + S$$

$$\text{and } J = \sqrt{J(J+1)} \cdot \frac{h}{2\pi}$$

where

J = total angular momentum quantum number (Non-negative integer or half integer)

The permitted values of J can be obtained by using Clebsch - Gordan series.

$$J = L + S, L + S - 1, \dots, |L - S|$$

If there is a single electron outside a closed shell then $J = j$ and j is either $l + \frac{1}{2}$ or $l - \frac{1}{2}$.

(ii) j - j Coupling

j - j coupling occurs in heavy atoms where spin-orbit coupling is large. If the spin and orbital angular momenta of each electron are coupled together strongly, then it may be considered that each electron behaves as a particle.

First sum the orbital and spin momenta of each electron separately and then sum the individual moments to given grand total.

$$j_i = l_i + s_i$$

and

$$J = \sum j_i$$

The Russel-Saunders coupling is more important for transition metals than j - j coupling.

Microstates

The electronic configuration of an atom, ion or molecule is not a complete description of arrangement of electrons in a subshell of an atom. For a given electronic configuration, there are several ways of arrangement of electrons in a subshell. For example, for p^2 -electronic configuration, there are 15 ways in which electrons can be arranged. Similarly for d^2 -configuration, there are 45 ways of arrangement of electrons. The different ways in which the electrons can be arranged in the orbitals of a subshell are called microstates of the configuration. Microstates are also called as atomic states.

$$\text{Number of microstates} = \frac{N!}{x!(N-x)!}$$

where

$N = 2(2l+1)$ = twice the number of orbitals.

x = number of electrons.

$$\begin{aligned} \text{For example microstates for } p^2\text{-configuration} &= \frac{6!}{2!(6-2)!} \\ &= \frac{6 \times 5 \times 4 \times 3 \times 2 \times 1}{2 \times 1 \times 4 \times 3 \times 2 \times 1} \\ &= 15 \end{aligned}$$

The fifteen microstates for p^2 -configuration are shown in the following table :

m_l	+1	0	-1	M_S	M_L
1	↑↓			0	+2
2		↑↓		0	0
3			↑↓	0	-2
4	↑	↓		0	+1
5	↓	↑		0	+1
6	↑		↓	0	0
7	↓		↑	0	0
8		↑	↓	0	-1
9		↓	↑	0	-1
10	↑	↑		+1	+1
11	↑		↑	+1	0
12		↑	↑	+1	-1
13	↓	↓		-1	+1
14	↓		↓	-1	0
15		↓	↓	-1	-1

Spectroscopic Terms : If the inter electronic repulsions are very small *i.e.* negligible, then the microstates of a given electronic configuration have the same energy. But atoms and molecules are compact, therefore, the inter-electronic repulsions are really strong and can not be ignored. As a result, microstates which correspond to different relative spatial arrangement of electrons have different energies. If the microstates that have the same energy are grouped together when inter-electronic repulsions are taken into account, the spectroscopically different energy levels are obtained and these energy levels are called **terms** or **atomic states**. These terms are characterized by symbols S and L . Thus,

$$\text{Atomic state} = {}^{2S+1}L$$

The values of L correspond to atomic states described as S, P, D, F, \dots which are parallel to the values of l for s, p, d, f, \dots orbitals.

The atomic states or terms are very important in the interpretation of spectra of coordination compounds.

Term Symbols : The term symbol for a particular atomic state or term is written as :

$${}^{2S+1}L_J$$

Ground State Term : Hund's Rule

The terms derived for an electronic configuration have different energies. For example, the p^2 -electronic configuration gives rise to three terms that are $3P, 1D$ and $1S$. These three terms have different

energies. These terms represent three states with different amount of inter-electronic repulsions. The ground state term (lowest energy) can be determined by using the Hund's rules.

1. For a given configuration, the ground state term (term of lowest energy) is that which has highest spin multiplicity. The ground state, therefore, have the highest number of unpaired electrons and this gives rise to minimum repulsion and high exchange energy. For example, the ground state term for p^2 -configuration is $3P$.
2. If the two states have the same spin multiplicity, the state with highest value of L will be the ground state. For example, for d^2 -configuration, the terms are $3F$, $3P$, $1S$, $1D$ and $1G$. $3F$ and $3P$ both have same spin multiplicity but $3F$ has higher value of L . Thus, $3F$ has lower energy than $3P$. Hence $3F$ is the ground state.
3. For a given electronic configuration, if spin multiplicities are same and the values of L are also same for two atomic states, then the state having lowest J value will be of lowest energy if the subshell is less than half filled, and the state having highest value of J will be of lowest energy if the subshell is more than half filled.

If the subshell is exactly half filled, it has only one value of J . This law is applicable when spin-orbit coupling is taken into account.

To Identify the Ground State Term and Ground State Term Symbol for Atoms

Following steps are used to identify the ground state:

- (1) Identify the microstate that has the highest value of S .
- (2) Find out the spin multiplicity ($2S + 1$).
- (3) Determine the maximum possible value of M_L ($= \sum m_l$) or L .
- (4) Select maximum value of J for more than half filled subshell and minimum value of J for less than half filled subshell.

Examples :

(i) p^2 -Configuration :

$$m_l \quad +1 \quad 0 \quad -1$$

1	1	
---	---	--

$$S = \frac{1}{2} + \frac{1}{2} = 1$$

Spin multiplicity $= 2S + 1 = 2 \times 1 + 1 = 3$

\therefore Ground state term $= 3P$

$$J = L + S, \dots, |L - S|$$

$$= 1 + 1, \dots, 1 - 1$$

$$= 2, 1, 0$$

Since p -subshell is less than half filled.

\therefore Ground state term symbol $= {}^3P_0$

$$L = M_L = +1 + 0 = +1, P \text{ state}$$

(ii) p^3 -Configuration :

$$m_l \quad +1 \quad 0 \quad -1$$

1	1	1
---	---	---

$$S = \frac{1}{2} + \frac{1}{2} + \frac{1}{2} = \frac{3}{2}$$

$$2S + 1 = 2 \times \frac{3}{2} + 1 = 4$$

\therefore Ground state term $= {}^4S$

For $L = 0$, and $S = \frac{3}{2}$

$$J = \left| 0 + \frac{3}{2} \right|, \dots, \left| 0 - \frac{3}{2} \right|$$

$$= 3/2$$

\therefore Ground state term symbol $= {}^4S_{3/2}$

(iii) For d^2 -Configuration (Ti^{2+} or V^{3+} ion) :

$$m_l \quad +2 \quad +1 \quad 0 \quad -1 \quad -2$$

$$M_L = 2 + 1 = 3, F \text{ state}$$

1	1			
---	---	--	--	--

$$S = \frac{1}{2} + \frac{1}{2} = 1$$

$$2S + 1 = 2 \times 1 + 1 = 3$$

Ground state term $= 3F$

$$J = |L + S|, \dots, |L - S|$$

$$= 3 + 1, \dots, |3 - 1|$$

$$= 4, 3, 2$$

Since d -orbital is less than half filled, lowest value of J will give the ground state term. Therefore, ground state term symbol $= {}^3F_2$. The d^n and d^{10-n} configurations give identical terms (Table 5.2).

Table 5.2 : Terms for d^n Configurations

Electronic Configuration	Ground State Term	Other Terms with Same Spin Multiplicity as that of Ground State
d^1, d^9	$2D$	—
d^2, d^8	$3F$	$3P, 1G, 1D, 1S$
d^3, d^7	$4F$	$4P, 2P, 2D, 2F, 2G, 2H$
d^4, d^6	$5D$	$3P, 3D, 3F, 3G, 3H,$ $1S, 1D, 1F, 1G, 1I$
d^5	$6S$	$4P, 4D, 4F, 4G, 2S, 2P,$ $2D, 2F, 2G, 2H, 2I$
d^{10}	$1S$	—

Terms in ground state and excited state with same multiplicity are important for discussion of electronic spectra.

To Identify the Ground State Term in Octahedral Complexes

- (1) Sketch the energy levels (t_{2g} and e_g) showing the d -electrons with maximum value of M_S .
- (2) Identify spin multiplicity.
- (3) Determine the maximum possible value of M_L or L .

Examples :

(i) High spin d^5 :

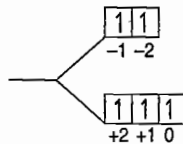

$$S = \frac{1}{2} + \frac{1}{2} + \frac{1}{2} + \frac{1}{2} + \frac{1}{2} = \frac{5}{2}$$

$$2S + 1 = 2 \times \frac{5}{2} + 1 = 6$$

$$M_L = 2 + 1 + 0 - 1 - 2 = 0, \quad \therefore S \text{ state}$$

\therefore Ground state term = 6S

(ii) Low spin d^5 :

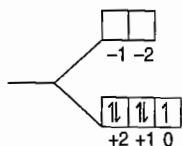

$$M_L = 2 + 2 + 1 + 1 + 0 = 6, \quad \therefore I \text{ state}$$

$$S = \frac{1}{2} - \frac{1}{2} + \frac{1}{2} - \frac{1}{2} + \frac{1}{2} = \frac{1}{2}$$

$$2S + 1 = 2 \times \frac{1}{2} + 1 = 2$$

\therefore Ground state term = 2I

(iii) High spin $d^5 S^1$:

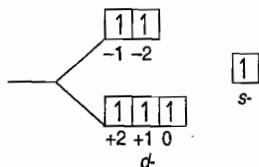

$$M_L = 2 + 1 + 0 - 1 - 2 + 0 = 0, \quad \therefore S \text{ state}$$

$$S = \frac{6}{2} = 3$$

$$2S + 1 = 2 \times 3 + 1 = 7$$

Ground state term = 7S

(iv) d^3 -Octahedral Symmetry :

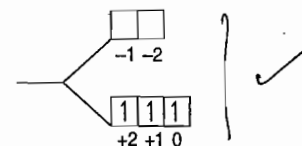

$$M_L = 2 + 1 + 0 = 3, \quad \therefore F \text{ state}$$

$$S = \frac{3}{2}$$

$$2S + 1 = 2 \times \frac{3}{2} + 1 = 4$$

\therefore Ground state term = 4F

SELECTION RULES

Intensities of Absorption Bands of Complexes : The electronic transitions between d -orbitals *i.e.* t_{2g} to e_g in octahedral complexes or e to t_2 in tetrahedral complexes are called $d-d$ transitions. When $d-d$ transitions occur in complexes with centres of symmetry such as regular octahedral complexes, the intensities of absorption bands are low. But when $d-d$ transitions occur in complexes which lack centres of symmetry such as tetrahedral complexes and octahedral *cis*-complexes of the type $MA_4 B_2$, relatively strong absorption bands are observed. For example, when conc. HCl is added to an aqueous solution of Co (II), the colour changes from pink of $[Co(H_2O)_6]^{2+}$ to intense blue colour of $[CoCl_4]^{2-}$.

The variation in the relative intensities of absorption bands can be explained by a series of selection rules.

(1) Laporte's Selection Rule

$$\Delta l = \pm 1$$

The transitions that occur between states of opposite parity *i.e.*, $g \leftrightarrow u$ are allowed. It means that $s \leftrightarrow p$, $p \leftrightarrow d$ and $d \leftrightarrow f$ transitions are allowed.

The transitions that occur between states of same parity *i.e.*, $g \leftrightarrow g$ or $u \leftrightarrow u$ are forbidden.

For example, $d-d$ transitions are forbidden because d -orbitals are gerade, *i.e.* these have centre of symmetry with respect to wave function.

Laporte's selection rule may also be given as follows. The transitions in which change in azimuthal quantum numbers is ± 1 *i.e.*, $\Delta L = \pm 1$, are Laporte allowed and absorbance may be high. If $\Delta L = 0$, the transitions are Laporte forbidden and, therefore, absorbance is low.

Relaxation in Laporte's Selection Rule

The $d-d$ transitions are Laporte forbidden and however, have much lower absorbance in the range of $10-50 \text{ L mol}^{-1} \text{ cm}^{-1}$ because there is slight relaxation in the Laporte's selection rule. The metal-ligands bonds in transition metal complexes are not rigid. When UV-visible light is incident on a complex, electronic transitions as well as vibrations occur simultaneously. In octahedral complexes the ligand vibrate in such a way that centre of symmetry is temporarily destroyed and there is a very small mixing of $p-d$ orbitals and thus $d-d$ transitions are not purely Laporte forbidden but there is slight relaxation in Laporte's rule. Therefore, the octahedral complexes show colour of low intensity.

In tetrahedral complexes there is no centre of symmetry and p - d mixing is more pronounced in tetrahedral complexes because t_2 molecular orbitals are formed from atomic d (gerade) and p (ungerade) orbitals. Tetrahedral complexes, therefore, absorb more strongly than octahedral complexes. Therefore, the tetrahedral complexes give more intense colour than octahedral complexes.

(2) Spin Selection Rule

Transitions between states of same multiplicity are allowed.

i.e. $\Delta S = 0$, spin allowed.

In other words, during electronic transition if spin of the electron is not changed, then the transition is spin allowed.

Transitions between states of different multiplicities are spin forbidden.

i.e. $\Delta S \neq 0$, spin forbidden.

For example : For d^2 -configuration in an octahedral field, there are four states with same spin multiplicity of 3 ($S = 1$) one of which is a ground state $3T_{1g}$ and the other three are excited states. [$3T_{2g}$, $3A_{2g}$ and $3T_{1g}(P)$]. Thus there are three transitions which are spin allowed. These are:

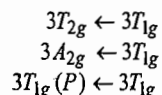

The transitions from $3T_{1g}$ to any other excited states are spin forbidden.

Relaxation in Spin Selection Rule

Spin-orbit coupling can relax the spin selection rule with the result that transitions may be observed from ground state of one spin multiplicity to excited state of different spin multiplicity. These spin-forbidden transitions are generally much weaker than spin allowed transitions. The strength of spin-orbit coupling in lighter atom is lower than for heavier atoms. The intensity of such bands increases with increase in atomic number. In first series transition metal complexes, spin-orbit coupling is weak and, therefore, the absorption bands are weak with a molar absorptivity about $1 \text{ L mol}^{-1} \text{ cm}^{-1}$. Spin-orbit coupling in $4d$ and $5d$ -transition metal complexes is strong, absorption bands, therefore, are stronger *i.e.*, intensities of these complexes are greater than for $3d$ -metal complexes.

A Laporte forbidden d - d transition is more intense than a spin forbidden transition.

Table 5.3 : Molar Absorbance for Various Electronic Transitions

Laporte's Selection Rule	Spin Selection Rule	Type of Spectra	Molar Absorbance $\epsilon (\text{L mol}^{-1} \text{ cm}^{-1})$	Examples
Allowed	Allowed	Charge transfer	10^3 - 10^4	MnO_4^- , CrO_3 $\text{Cr}_2\text{O}_7^{2-}$, $[\text{TiCl}_6]^{2-}$
Partly allowed (some p - d mixing)	Allowed	d - d	10^2 - 10^3	$[\text{CoCl}_4]^{2-}$, $[\text{CoBr}_4]^{2-}$
Forbidden	Allowed	d - d	8-10	$[\text{Ti}(\text{H}_2\text{O})_6]^{3+}$, $[\text{Ti}(\text{NH}_3)_6]^{3+}$ $[\text{Ni}(\text{NH}_3)_6]^{2+}$

Partly allowed some p - d mixing	Forbidden	d - d	2-3	$[\text{MnCl}_4]^{2-}$, $[\text{MnBr}_4]^{2-}$
Forbidden	Forbidden	d - d	0.1-0.2	$[\text{Mn}(\text{H}_2\text{O})_6]^{2+}$

Splitting of Terms in Octahedral and Tetrahedral Complexes

The wave function for S, P, D, F states have same symmetry as the wave functions for the corresponding sets of s, p, d, f orbitals.

An s -orbital is spherically symmetrical and p -orbitals lie on axes. There is no effect of octahedral or tetrahedral field on s -orbitals *i.e.*, neither energy of s -orbital is increased nor splitting of an s -orbital occurs. Since S state has same symmetry as that of s -orbital, so there is also no effect of octahedral and tetrahedral fields on S state.

Since all the p -orbitals lie on axes, so there is no splitting of p -orbitals in octahedral and tetrahedral fields but energy of p -orbital is raised equally. P state has same symmetry as that of p -orbitals. There is no splitting of P state but its energy is raised as that of p -orbitals.

A set of d -orbitals is split into t_{2g} and e_g (in octahedral field) or e and t_2 (in tetrahedral field). Therefore, a D term is split into T_{2g} and E_g (in octahedral field) or E and T_2 (in tetrahedral field).

Similarly, F term is split into three terms T_{1g} , T_{2g} and A_{2g} (in octahedral field) or T_1 , T_2 and A_2 (in tetrahedral field).

In an octahedral field, splitting of D and F states are shown in Figure 5.6 and 5.7.

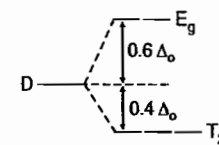

Figure 5.6 Splitting of D state in octahedral field. triply degenerate T_{2g} level is $0.4 \Delta_o$ below the barycentre and doubly degenerate E_g orbital is $0.6 \Delta_o$ above the barycentre.

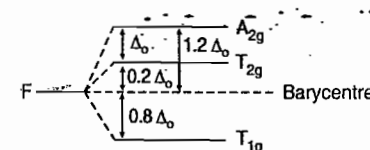

Figure 5.7 Splitting of F state in octahedral field. singly degenerate A_{2g} state is $1.2 \Delta_o$ above the barycentre, triply degenerate T_{2g} state is $0.2 \Delta_o$ above the barycentre and triply degenerate T_{1g} state is $0.8 \Delta_o$ below the barycentre.

Table 5.4 Splitting of Atomic States in Octahedral and Tetrahedral Complexes

Term	Terms in Octahedral Field	Terms in Tetrahedral Field
S	A_{1g}	A_1
P	T_{1g}	T_1
D	$T_{2g} + E_g$	$T_2 + E$
F	$T_{1g} + T_{2g} + A_{2g}$	$T_1 + T_2 + A_2$
G	$A_{1g} + E_g + T_{1g} + T_{2g}$	$A_1 + E + T_1 + T_2$
H	$E_g + 2T_{1g} + T_{2g}$	$E + 2T_1 + T_2$

INTERPRETATION OF ELECTRONIC SPECTRA OF HIGH SPIN OCTAHEDRAL AND TETRAHEDRAL COMPLEXES (ORGEL DIAGRAMS)

Orgel diagrams are particularly useful in the interpretation of spin allowed electronic transitions of tetrahedral and high spin octahedral complexes but not for low spin octahedral complexes. The spin allowed electronic transitions occur between the two energy states (i.e., terms) that have same spin multiplicity. The energy difference between ground state and any of the excited state is greater than kT (k = Boltzmann constant and T = absolute temperature), almost all the molecules of a complex compound are present in their ground states. Therefore, the electronic transitions occur from ground state to excited states. In some complexes (like high spin Mn^{2+} octahedral complexes) spin forbidden transitions also occur but the intensity of bands is weaker (relaxation in spin selection rule due to spin-orbit coupling) than the spin allowed transitions. An Orgel diagram for a given metal ion shows the change in energy of individual terms with change in ligand field strength. As the magnitude of ligand field strength increases the excited states with different symmetry and same spin multiplicity may cross one another.

Orgel diagrams can also be used for all octahedral complexes of d^1, d^2, d^3, d^8 and d^9 metal ions irrespective of strength of ligands (i.e., either the ligand is weak or strong) because weak or strong ligand field for these metal ions gives rise to identical energy states.

Spectra of d^1 Metal Ions in Octahedral Field

In a free metal ion of d^1 -configuration, there is no inter-electronic interaction and all the five d -orbitals are degenerate and, therefore, it has only one term i.e., 2D . Under the influence of an octahedral field, either the ligand is weak or strong the d -orbitals are split into t_{2g} and e_g sets of orbitals. The magnitude of splitting, Δ_o depends upon the nature of ligands. Since wave function of 2D term is similar to that of d -orbital, therefore, 2D term is split into ${}^2T_{2g}$ and 2E_g terms in octahedral complex. The ground state term is ${}^2T_{2g}$ which is similar to t_{2g} orbitals having one electron and 2E_g term is similar to e_g orbitals having no electron which is the excited state. The energy gap between ${}^2T_{2g}$ and 2E_g states varies with the nature of ligands. Weaker the ligand lower will be the energy gap between ${}^2T_{2g}$ and 2E_g states and stronger the ligand, higher will be energy gap between ${}^2T_{2g}$ and 2E_g states. The electron always occupies the ground state term. When light is incident on the octahedral complex of

d^1 -configuration, the electron gets excited from ${}^2T_{2g}$ to 2E_g state as shown in Figure 5.8. There is only one electronic transition represented as ${}^2E_g \leftarrow {}^2T_{2g}$. As the strength of ligand increases, energy of transition increases. For example, transitions occur at 13000 cm^{-1} , 18900 cm^{-1} , 20300 cm^{-1} and 22300 cm^{-1} in $[\text{TiCl}_6]^{3-}$, $[\text{TiF}_6]^{3-}$, $[\text{Ti}(\text{H}_2\text{O})_6]^{3+}$ and $[\text{Ti}(\text{CN})_6]^{3-}$ respectively because strength of ligands increases according to spectro chemical series as $\text{Cl}^- < \text{F}^- < \text{H}_2\text{O} < \text{CN}^-$.

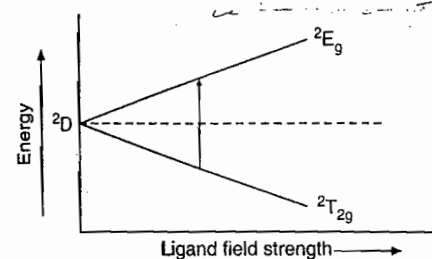
Figure 5.8: Orgel diagram for d^1 octahedral complex

The absorption band in the spectra of $[\text{Ti}(\text{H}_2\text{O})_6]^{3+}$ is broad because of Jahn-Teller distortion. This Jahn-Teller distortion splits the 2E_g state into ${}^2A_{1g}$ and ${}^2B_{1g}$. This distortion also causes small splitting of ground state (${}^2T_{2g}$) into 2E_g and ${}^2B_{2g}$ [Figure 5.9(a)].

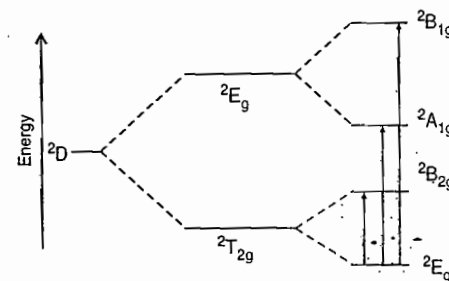

Figure 5.9(a)

In complex ion $[\text{Ti}(\text{H}_2\text{O})_6]^{3+}$ absorption maximum observed at 20300 cm^{-1} and also the absorption maximum has a shoulder at 17400 cm^{-1} because of Jahn-Teller distortion. This shoulder is responsible for broad band in the spectrum as shown in Figure 5.3.

It has also been suggested that the electronic excited state of $[\text{Ti}(\text{H}_2\text{O})_6]^{3+}$ has the configuration $t_{2g}^0 e_g^1$ and so in the excited state of the complex e_g orbitals are electronically degenerate. Therefore, the single electronic transition is really the superposition of two transitions, one from an octahedral (Oh) ground state ion to an octahedral excited state ion and a lower energy transition from an octahedral ground state ion to a lower energy tetragonally distorted excited state ion (D_{4h}). Since these two

transitions have slightly different energies, therefore, the bands overlap one another and can not be resolved.

Thus, the unresolved superimposed band results in an asymmetric and broad band. The splitting of e_g state is shown in Figure 5.9(b):

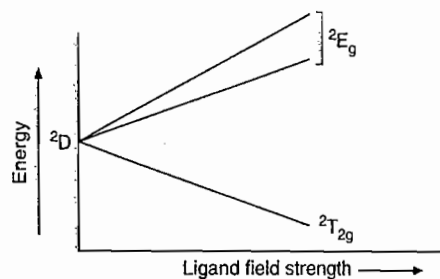
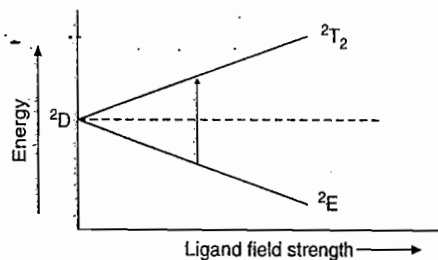

Figure 5.9(b)

Spectra of d^1 Metal ion in Tetrahedral Complexes

The tetrahedral complexes are always high spin complexes. The Orgel diagram, therefore, can be used to interpret their spectra. The tetrahedral complexes show more intense absorbance than those of octahedral complexes because of some $p-d$ mixing. Due to some $p-d$ mixing the degenerate d -orbitals split into e and t_2 sets of orbitals. The e orbitals are of lower in energy and t_2 orbitals are of higher in energy. The single electron will occupy the any of the two e orbitals. On absorption of light electron gets excited from e orbital to one of the t_2 orbitals. Transition of electron is spin allowed. The term for metal ion of d^1 configuration is 2D and it splits into 2E and 2T_2 states. 2E is of lower energy and 2T_2 is of higher energy. Therefore, electron transition occurs from 2E to 2T_2 as shown in Figure 5.10. The energy level diagram for d^1 tetrahedral complex is the inverse of d^1 octahedral complex.

Figure 5.10 Orgel diagram for d^1 tetrahedral complex

There is only one electronic transition from 2E to 2T_2 represented as ${}^2T_2 \leftarrow {}^2E$.

Since there is only one transition, therefore, only one absorption band is observed in electronic spectra.

Spectra of d^9 -Octahedral Complexes

In octahedral complexes of d^9 -metal ions, d -orbitals split into t_{2g} and e_g orbitals. On absorption of light an electron gets excited from a t_{2g} to a e_g orbital. The ground state term of free d^9 metal ion is 2D which splits into ${}^2T_{2g}$ and 2E_g states in octahedral complex. In an octahedral complex the electronic configuration is $t_{2g}^6 e_g^3$. The e_g orbitals are doubly degenerate corresponding to electronic arrangements, $t_{2g}^6 d_{x^2-y^2}^2 d_{z^2}^1$ or $t_{2g}^6 d_{x^2-y^2}^1 d_{z^2}^2$ and has the designation 2E_g .

In a d^9 octahedral complex a hole may be considered in e_g orbitals. When transition occurs, the electronic configuration becomes $t_{2g}^5 e_g^4$ and now there will be a hole in a t_{2g} orbital. This hole in the t_{2g} orbitals may be placed in any of the three ways $d_{xy}^2, d_{yz}^2, d_{zx}^2$ or $d_{xy}^1, d_{yz}^1, d_{zx}^1$ or $d_{xy}^2, d_{yz}^1, d_{zx}^1$ or $d_{xy}^1, d_{yz}^2, d_{zx}^2$, therefore, the configuration is triply degenerate and the term corresponding to this configuration is ${}^2T_{2g}$. Thus, the energy of 2E_g is lower and that of ${}^2T_{2g}$ is higher. In other words, 2E_g state is ground state and ${}^2T_{2g}$ is excited state. Since there is a hole in 2E_g state, therefore, there is a hole transition from 2E_g to ${}^2T_{2g}$ which is similar to electron transition and can be represented as ${}^2T_{2g} \leftarrow {}^2E_g$. This is opposite of the order of energies of the orbitals (t_{2g} lower than e_g) as shown Figure 5.11.

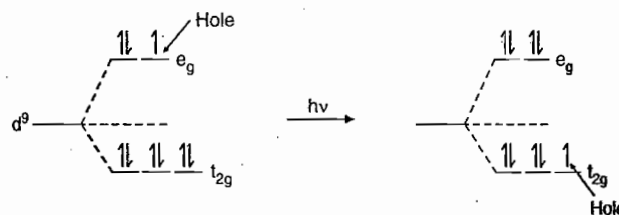
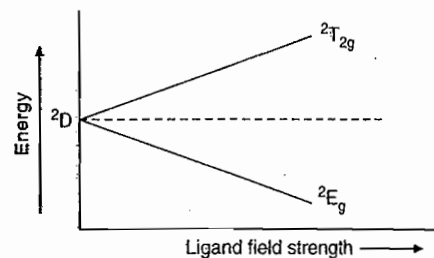
Figure 5.11 Splitting of d -orbitals in d^9 octahedral complexesFigure 5.12 Orgel diagram for d^9 octahedral complexes

The single electronic transition in d^1 octahedral complex is ${}^2E_g \leftarrow {}^2T_{2g}$ and that for the d^9 octahedral complex is ${}^2T_{2g} \leftarrow {}^2E_g$. These two cases of d^1 and $d^{10-1} = d^9$ are inversely related. In general, for high spin of d^n and d^{10-n} high complexes are inversely related.

The Orgel diagram for a d^9 octahedral complex is analogous to the d^1 tetrahedral complex. In general, the Orgel diagram for a d^n high spin octahedral complexes is analogous to d^{10-n} tetrahedral complex and *vice-versa*.

The absorption band of $[\text{Cu}(\text{H}_2\text{O})_6]^{2+}$ complex in electronic spectra is observed as broad band because of the Jahn-Teller distortion.

Explanation of Broad Band in Electronic Spectra of d^9 -Octahedral Complexes

The $[\text{Cu}(\text{H}_2\text{O})_6]^{2+}$ complex absorbs in the visible region at 12000 cm^{-1} and this complex is blue coloured.

For a d^9 -octahedral complex, the ground state is 2E_g and the excited state is ${}^2T_{2g}$. We expect that excitation of a hole occurs from 2E_g to ${}^2T_{2g}$ and a single absorption band is observed. But due to Jahn-Teller distortion, 2E_g state splits into B_{1g} (lower energy) and A_{1g} (higher energy) and ${}^2T_{2g}$ state splits into B_{2g} (lower energy) and E_g (higher energy) of as shown in Figure 5.13. Now electron transition may occur from B_{1g} (now ground state) to the A_{1g} , the B_{2g} or the E_g states. Thus, three band may be observed. But since due to Jahn-Teller distortion splitting of 2E_g and ${}^2T_{2g}$ states is poor, so the three absorption bands overlap together showing a broad band as shown in the Figure 5.14.

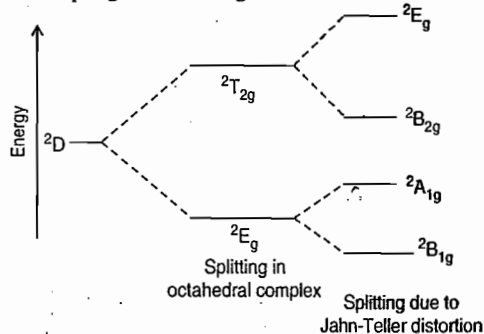

Figure 5.13 Splitting of 2D state in d^9 octahedral complexes and in due to Jahn-Teller distortion.

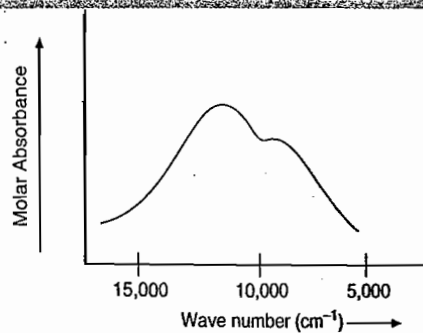

Figure 5.14 Spectrum for $[\text{Cu}(\text{H}_2\text{O})_6]^{2+}$ complex ion.

Electronic spectra of $\text{CuSO}_4 \cdot 5\text{H}_2\text{O}$

$\text{CuSO}_4 \cdot 5\text{H}_2\text{O}$ is blue coloured compound and shows an absorption band at $\sim 12000 \text{ cm}^{-1}$.

The structure of $\text{CuSO}_4 \cdot 5\text{H}_2\text{O}$ is shown in the Figure 5.15.

The crystal structure of $\text{CuSO}_4 \cdot 5\text{H}_2\text{O}$ shows that each Cu atom is coordinated to four H_2O and two SO_4 groups in *trans* positions and the fifth H_2O molecule is not bound to Cu directly but it forms hydrogen bonds with two SO_4 groups on neighbouring Cu atoms and two hydrogen bonds with *cis*- H_2O molecules bound to one of the Cu atoms. Therefore, in $\text{CuSO}_4 \cdot 5\text{H}_2\text{O}$ there is octahedral environment round the Cu^{2+} ion. The absorption band in electronic spectrum is assigned to ${}^2T_{2g} \leftarrow {}^2E_g$ and it is similar to $[\text{Cu}(\text{H}_2\text{O})_6]^{2+}$ complex ion.

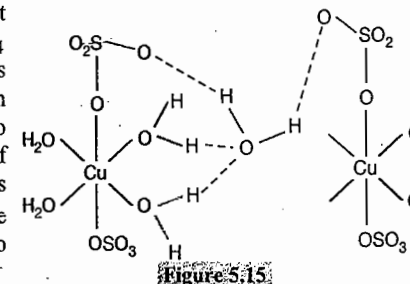
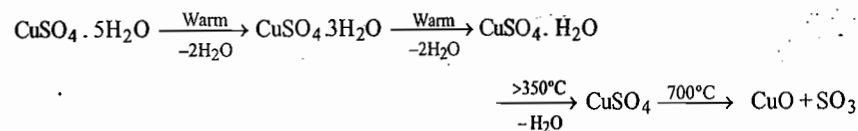

Figure 5.15

Now it is observed that one of the H_2O molecules is bound more strongly than the other four. These four water molecules can be removed by warming or over P_4O_{10} . The fifth H_2O molecule can be removed by heating the compound above 350°C .



Electronic Spectra of d^9 Tetrahedral Complexes

In tetrahedral complexes of d^9 metal ions, d -orbitals split into t_2 of higher and e of lower energy orbitals (Figure 5.16). But the splitting is reverse of d^9 -octahedral complexes. The ground state term of free metal cation is 2D . In tetrahedral complexes 2D state splits into 2T and 2E states as shown in Figure 5.17. But energy of these states is also reverse of the d^9 -octahedral complexes. Thus, in a tetrahedral complex energy of 2T_2 is lower and that of 2E is higher. Hole transition occurs from 2T_2 to 2E state resulting in one absorption band.

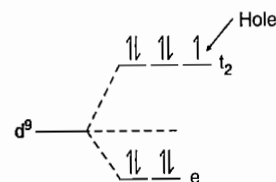

Figure 5.16 Crystal field splitting in d^9 tetrahedral complex.

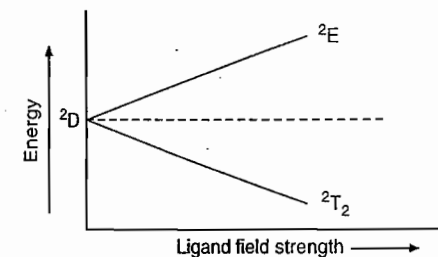

Figure 5.17 Orgel diagram for d^9 tetrahedral complex.

It is to be noted that if there is one or more holes in a d^n -octahedral complex, then there will also be same number of holes in a tetrahedral complex. The number of holes in any state of a complex will never be more than the number of electrons to be excited.

Electronic Spectra of High Spin d^6 -Octahedral Complexes

In a high spin octahedral complex of d^6 metal ion, the d -orbitals split into t_{2g} (lower energy) and e_g orbitals (higher energy) as shown in the Figure 5.18.

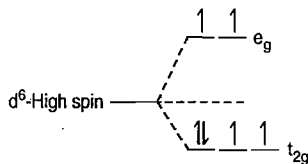

Figure 5.18: Splitting of d -orbitals in octahedral field

Transitions of unpaired electron from t_{2g} orbitals to e_g orbitals are restricted because there will be change in spin multiplicity *i.e.*, these transitions are spin forbidden. Transition of that electron in t_{2g} orbital which is paired and has the opposite spin to all the other electrons can occur because this transition is spin allowed. Since there is transition of only one electron, therefore, this transition is similar to transition in d^1 -octahedral complexes.

The ground state term of free d^6 -metal ion is 5D . In high spin octahedral complexes 5D term splits into $^5T_{2g}$ (ground state) and 5E_g (excited state) as shown in the Figure 5.19. There is only one electronic transition from $^5T_{2g}$ to 5E_g represented as $^5E_g \leftarrow ^5T_{2g}$. Only single absorption band is observed corresponding to $^5E_g \leftarrow ^5T_{2g}$ transition. The absorption band broadened or split because of spin-orbit coupling and Jahn-Teller distortion in excited state configuration as shown in Figure 5.20.

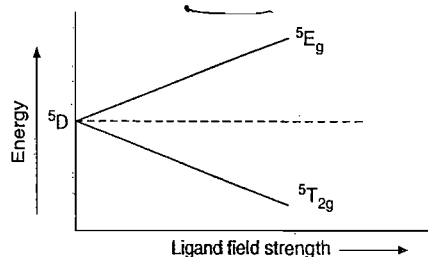

Figure 5.19: Orgel diagram for d^6 high spin octahedral complex

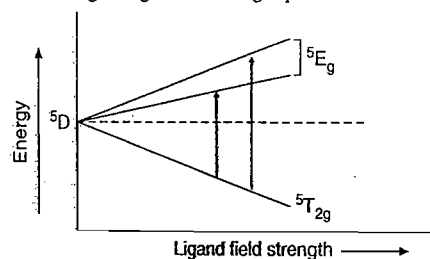

Figure 5.20: Splitting of 5E_g term due to Jahn-Teller distortion in excited state

The absorption band in the electronic spectra of d^6 -high spin complexes is usually found between 10000 and 11000 cm^{-1} as shown in Figure 5.21. $[\text{Fe}(\text{H}_2\text{O})_6]^{2+}$ complex ion is pale green and it shows absorption band at 11000 cm^{-1} .

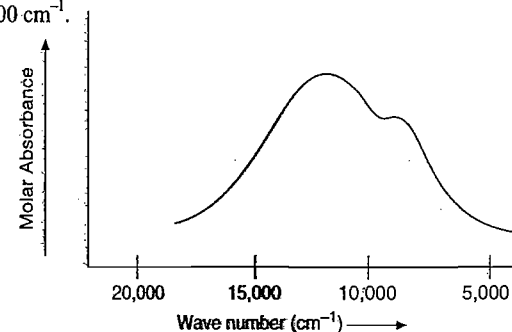

Figure 5.21: Electronic spectrum of $[\text{Fe}(\text{H}_2\text{O})_6]^{2+}$ complex ion

Electronic Spectra of d^6 -tetrahedral complex

Most Fe (II) complexes are octahedral but halides ($X = \text{Cl}^-$, Br^- , I^-) and NCS^- form tetrahedral complexes with Fe (II). In a tetrahedral complexes of Fe^{2+} ion, the d -orbitals split into e (lower energy) and t_2 (higher energy) orbitals as shown in the Figure 5.22.

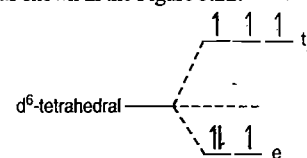

Figure 5.22: Splitting of d -orbitals in d^6 -tetrahedral complex

Transition of paired electron having spin opposite to all other electrons in e orbitals can occur because this transition is spin allowed. The ground state term for free Fe^{2+} ion (d^6) is 5D . In tetrahedral complexes of Fe^{2+} ion 5D term splits into 5E (ground state) and 5T_2 (excited state) as shown in Figure 5.23. In $[\text{FeCl}_4]^{2-}$ only single absorption band appears at 4000 cm^{-1} (near infra red region) because of $^5T_2 \leftarrow ^5E$ transition. For $[\text{FeCl}_4]^{2-}$ Δ_o is 4000 cm^{-1} . $[\text{FeCl}_4]^{2-}$ is colourless because it absorbs in IR region.

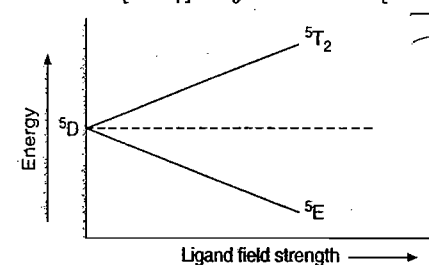

Figure 5.23: Orgel diagram for $[\text{FeCl}_4]^{2-}$ complex ion

Electronic Spectra of d^4 -High Spin Octahedral Complexes

In a high spin octahedral complexes of Cr^{2+} (d^4) ion split the d -orbitals into t_{2g} (lower energy) and e_g (higher energy) orbitals as shown in Figure 5.24.

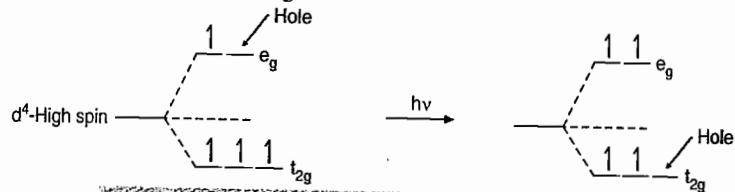

Figure 5.24 Splitting of d -orbitals in d^4 -high spin complex

On absorption of light, an electron from a t_{2g} orbital gets excited to a e_g orbital. The ground state term for free d^4 metal ion is 5D which splits into 5E_g (ground state) and $^5T_{2g}$ (excited state) in a high spin complex. In a high spin octahedral complex, the electronic configuration is $t_{2g}^3 e_g^1$. The e_g orbitals are electronically degenerate, corresponding to electronic arrangements $t_{2g}^3 d_{x^2-y^2}^1 d_{z^2}^0$ or $t_{2g}^3 d_{x^2-y^2}^0 d_{z^2}^1$ and is represented as 5E_g . In a d^4 -high spin octahedral complex a hole may be considered in e_g orbitals. When transition occurs, the electronic configuration becomes $t_{2g}^2 e_g^2$ and now there will be a hole in t_{2g} orbitals as shown in Figure 5.24. This hole in the t_{2g} orbitals may be placed in either of the three ways, $d_{xy}^1 d_{yz}^1 d_{zx}^0 e_g^2$ or $d_{xy}^1 d_{yz}^0 d_{zx}^1 e_g^2$ or $d_{xy}^0 d_{yz}^1 d_{zx}^1 e_g^2$, therefore, the configuration ($t_{2g}^2 e_g^2$) in excited state is triply degenerate and the term corresponding to this configuration in excited state is $^5T_{2g}$. Therefore, the energy of 5E_g is lower (ground state) and that of $^5T_{2g}$ is higher (excited state) as shown in Figure 5.25. Since there is a hole in 5E_g state, so there is a hole transition from 5E_g to $^5T_{2g}$ which is represented as $^5T_{2g} \leftarrow ^5E_g$. This is opposite of the order of energies of orbitals (t_{2g} lower than e_g) as shown in Figure 5.25.

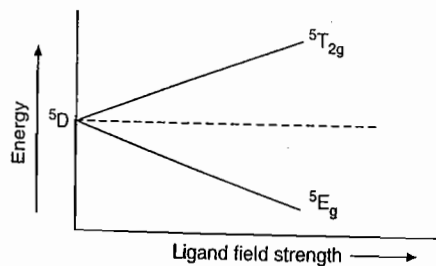

Figure 5.25 Orgel diagram for d^4 -high spin octahedral complexes

The absorption band for Cr^{2+} high spin complexes is typically a broad band in the region of 16000 cm^{-1} with another band at around $10,000 \text{ cm}^{-1}$ because of Jahn-Teller distortion. Due to Jahn-Teller distortion splitting of free ion 5D term occurs as shown in Figure 5.26.

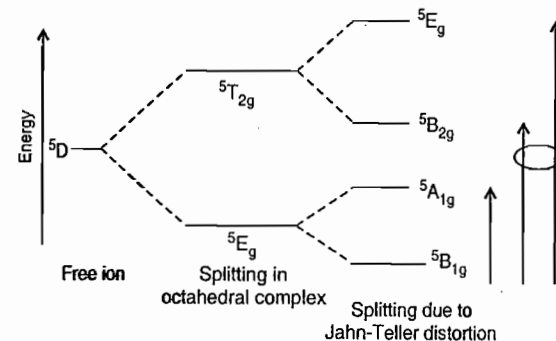

Figure 5.26 Crystal field splitting of 5D term of Cr^{2+} ion in d^4 -high spin octahedral complex

Due to Jahn-Teller distortion following three transitions are possible :

- (i) $^5A_{1g} \leftarrow ^5B_{1g}$ (ii) $^5B_{2g} \leftarrow ^5B_{1g}$
- (iii) $^5E_g \leftarrow ^5B_{1g}$

The two bands due to $^5B_{2g} \leftarrow ^5B_{1g}$ and $^5E_g \leftarrow ^5B_{1g}$ are assigned to superimposed. Thus, the two bands appear which are very closer and as a result a broad band appears as shown in Figure 5.27.

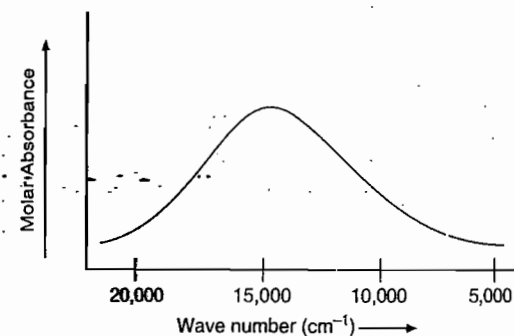

Figure 5.27 Electronic spectrum of a d^4 -high spin complex

Electronic Spectra of d^4 -Tetrahedral Complexes

In tetrahedral complexes of d^4 -metal ion, d -orbitals split into e (lower energy) and t_2 (higher energy) orbitals as shown in Figure 5.28, but the splitting is reverse of the d^4 -high spin octahedral complexes.

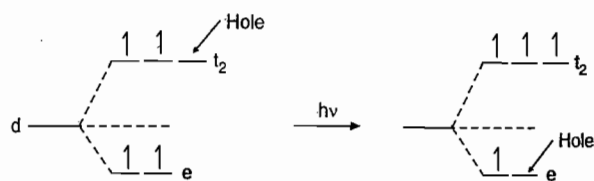

Figure 5.28

In a tetrahedral complex of d^4 -metal ion the electronic configuration is $e^2 t_2^2$. The t_2 orbitals are triply degenerate corresponding to electronic arrangement $e^2 d_{xy}^1 d_{yz}^1 d_{zx}^0$, $e^2 d_{xy}^1 d_{yz}^0 d_{zx}^1$ and $e^2 d_{xy}^0 d_{yz}^1 d_{zx}^1$ and the term corresponding to this configuration (ground state) is 5T_2 . In a d^4 -tetrahedral complex a hole may be considered in t_2 orbitals. When transition occurs, the electronic configuration becomes $e^1 t_2^3$ and now there will be a hole in e -orbitals. This hole in e -orbitals can be placed in any of the two ways $d_{x^2-y^2}^1 d_{z^2}^0 t_2^3$ or $d_{x^2-y^2}^0 d_{z^2}^1 t_2^3$. Therefore, the configuration in excited state is doubly degenerate and the term corresponding to this state is 5E .

Thus, the energy of 5T_2 is lower and that of 5E is higher as shown in Figure 5.29. This is opposite of the order of energy of orbitals (e lower than t_2) of d^4 -high spin octahedral complex.

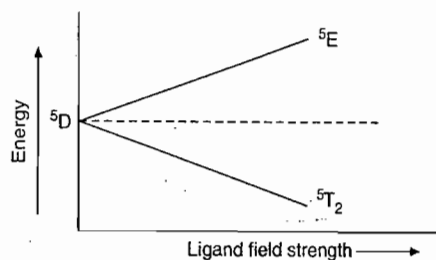
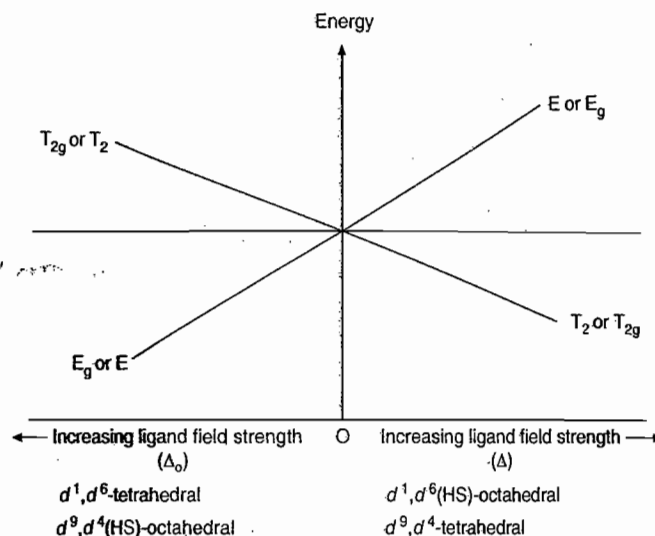

Figure 5.29

There is one absorption band in electronic spectra due to the $^5E \leftarrow ^5T_2$ transition.

Figure 5.30 Combined Orgel diagram for d^1, d^6, d^9 and d^4 metal complexes

Electronic Spectra of d^2 -Octahedral Complexes

In octahedral complexes (whether the ligand is weak or strong) of d^2 -metal ion like $[V(H_2O)_6]^{3+}$, the d -orbitals split into t_{2g} (lower energy) and e_g (higher energy) orbitals. The ground state of d^2 -metal ion in octahedral complex have two electrons with parallel spin in any two of the three lower energy orbitals: d_{xy}, d_{yz} and d_{zx} . The ground state, based on the t_{2g}^2 configuration is triply degenerate ($^3T_{1g}$ state) because there are three ways of arrangement of the electrons with parallel spins in t_{2g} orbitals: $d_{xy}^1 d_{yz}^1$ or $d_{yz}^1 d_{zx}^1$ or $d_{xy}^1 d_{zx}^1$. If one electron is excited to a e_g orbital, the electronic configuration becomes $t_{2g}^1 e_g^1$. Then the most stable (lowest energy) arrangement of electrons for this configuration will be when the two electron are present in orbitals as far apart as possible *i.e.*, at right angle to each other. For example, if one electron is present in d_{xy} orbital, the other electron will be in the d_{z^2} orbital rather than in the $d_{x^2-y^2}$ orbital. There are three ways of arranging these two electrons in orbitals perpendicular to each other: $d_{xy}^1 d_{z^2}^1, d_{yz}^1 d_{z^2}^1, d_{zx}^1 d_{z^2}^1$.

Thus, this state is triply degenerate and is represented as $^3T_{2g}$. This state have lowest energy because two electrons occupy more space in all the three directions and causes less electron-electron repulsion.

There is an another triply degenerate arrangements of the two electrons in which two electrons occupy the orbitals which are relatively closer together *i.e.*, the orbitals are at 45° to each other $d_{xy}^1 d_{x^2-y^2}^1, d_{zx}^1 d_{z^2}^1, d_{yz}^1 d_{z^2}^1$. This arrangement is represented by $^3T_{1g}$ state. This state will be higher in energy because both electrons occupy space only in one plane.

If both the electrons are excited to e_g orbitals, there is only one arrangement of two electrons with parallel spins.

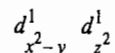

This state is electronically non-degenerate and can be represented as ${}^3A_{2g}$.

Thus, there are three transitions from ground state to excited states of the same multiplicity. The three electronic transitions for d^2 -octahedral complex are shown in Figure 5.31.

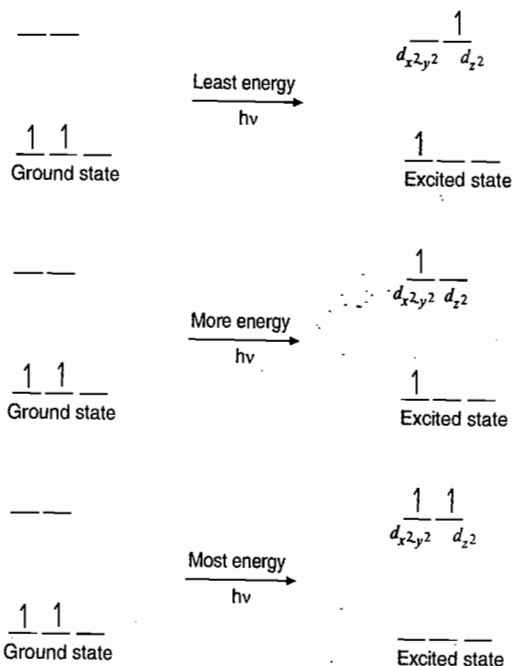
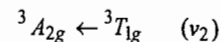
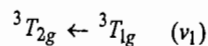
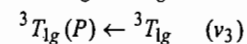

Figure 5.31

The terms arising for d^2 -configuration are 3F , 3P , 1S , 1D and 1G out of which 3F is the ground state term. The excited state of maximum multiplicity ($=3$) is only 3P . In octahedral complexes 3F term splits into ${}^3T_{1g}(F)$, ${}^3T_{2g}(F)$ and ${}^3A_{2g}(F)$. The term 3P does not split in octahedral complexes but it transforms into ${}^3T_{1g}(P)$ term and energy of the terms varies as the ligand field strength is changed as shown in Figure 5.32. The two ${}^3T_{1g}$ states are distinguished by adding the symbol (F) or (P) after ${}^3T_{1g}$ term as ${}^3T_{1g}(F)$ and ${}^3T_{1g}(P)$. The ground state term of d^2 -in octahedral complex is ${}^3T_{1g}(F)$ and excited states are ${}^3T_{2g}$, ${}^3A_{2g}$ and ${}^3T_{1g}(P)$. Three spin allowed transitions are possible as shown below:



and



Transitions from ${}^3T_{1g}$ ground state to any of the singlet states are spin forbidden. Therefore, only three absorption bands may appear in the spectrum of $[\text{V}(\text{H}_2\text{O})_6]^{3+}$.

The separation between the ground state ${}^3T_{1g}(F)$ and the excited states ${}^3T_{2g}$, ${}^3A_{2g}$ and ${}^3T_{1g}(P)$ increases with increase in ligand field strength. Thus, as the ligand field strength increases, the transitions require higher energies and the absorption bands shift towards the UV-region.

For $[\text{V}(\text{H}_2\text{O})_6]^{3+}$ which shows blue colour, two absorption bands corresponding to ${}^3T_{2g} \leftarrow {}^3T_{1g}$ and ${}^3T_{1g}(P) \leftarrow {}^3T_{1g}$ are observed in visible region at 17200 cm^{-1} and 25700 cm^{-1} respectively.

The absorptions are weak in intensities and have molar absorbance ($\text{L mol}^{-1} \text{ cm}^{-1}$) 3.5 and 6.6 respectively.

The third transition ${}^3A_{2g} \leftarrow {}^3T_{1g}$ corresponds to excitation of both electrons and requires high energy. Thus, the band corresponding to this transition is of low intensity and does not experimentally observed. Also, this band is hidden by a high intensity charge transfer band in the UV-region. All the three bands are observed when V^{3+} is incorporated into $\alpha\text{-Al}_2\text{O}_3$ corundum lattice in which a small portion of Al^{3+} have been replaced by V^{3+} ions.

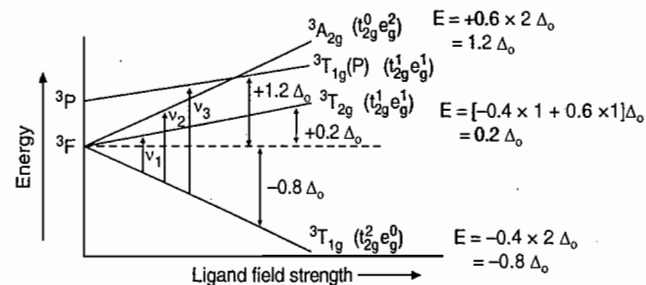

Figure 5.32 Orgel diagram for d^2 -octahedral complexes.

It can be seen from the Figure 5.32 that the lowest energy transition ${}^3T_{2g} \leftarrow {}^3T_{1g}$ gives the value of Δ_o , i.e., difference between the energy of ${}^3T_{1g}$ and ${}^3T_{2g}$ is $[0.2 - (-0.8)] \Delta_o = \Delta_o$.

However, the ${}^3T_{1g}(F)$ state can mix with ${}^3T_{1g}(P)$ state causing a slight curvature. Therefore, the energy of ${}^3T_{2g} \leftarrow {}^3T_{1g}$ will not give the exact value of Δ_o .

Alternatively, the difference between the energy of first transition (${}^3T_{2g} \leftarrow {}^3T_{1g}$) and that of second transition (${}^3A_{2g} \leftarrow {}^3T_{1g}$) gives the value of Δ_o . Usually the separation between first and third bands gives the value of Δ_o .

Energy of ${}^3A_{2g} \leftarrow {}^3T_{1g}$ transition - Energy of ${}^3T_{1g} \leftarrow {}^3T_{1g}$ transition = $2\Delta_o - \Delta_o = \Delta_o$.

Unfortunately, the third band can not always be observed, in such case a more complicated analysis is required which will be discussed in Tanabe - Sugano diagram on page 5.48.

As the ligand field strength increases the ${}^3A_{2g}$ and ${}^3T_{1g}(P)$ states cross each other and energy of ${}^3A_{2g}$ becomes higher than that of ${}^3T_{1g}(P)$. For stronger ligand the energy of ${}^3A_{2g} \leftarrow {}^3T_{1g}(F)$ becomes higher than that of ${}^3T_{1g}(P) \leftarrow {}^3T_{1g}(F)$.

At or near the cross over point two bands viz. ${}^3A_{2g} \leftarrow {}^3T_{1g}$ and ${}^3T_{1g}(P) \leftarrow {}^3T_{1g}(F)$ can overlap each other and thus only two bands are observed (Figure 5.33).

For an extremely weak ligand octahedral complex, three absorption bands corresponding to three transitions as discussed earlier are obtained and the separation between first and third bands gives the value of Δ_o .

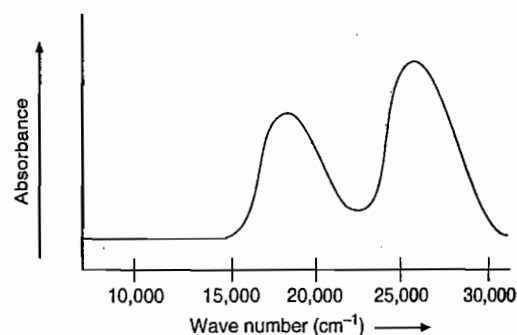

Figure 5.33 Absorption spectra for $[\text{Ni}(\text{H}_2\text{O})_6]^{2+}$.

Electronic Spectra of d^2 -Tetrahedral Complexes

In tetrahedral complexes of d^2 -metals ions like $[\text{VCl}_4]^-$ and $[\text{VBr}_4]^-$ the d -orbitals split into e (lower energy) and t_2 (higher energy) orbitals giving rise to electronic configuration $e^2 t_2^0$. In ground state there is only one arrangement of two electrons with parallel spins $d_{x^2-y^2}^1 d_{z^2}^1$. Thus, this state is electronically non-degenerate and is represented as 3A_2 . If one of the two electrons is excited to a t_2 orbital, the electronic configuration becomes $e^1 t_2^1$. Corresponding to this electronic configuration, the lower energy state will be that when the two electrons are present in orbitals as far apart as possible. The two electrons can be arranged in either of the three ways: $d_{x^2-y^2}^1 d_{xy}^1$, $d_{x^2-y^2}^1 d_{zx}^1$ and $d_{x^2-y^2}^1 d_{yz}^1$. Therefore, this state is triply degenerate and is represented as 3T_2 . There is another triplet state corresponding to $e^1 t_2^1$ configuration in which the two electrons occupy the orbitals which are relatively closer together: $d_{x^2-y^2}^1 d_{xy}^1$, $d_{z^2}^1 d_{zx}^1$ and $d_{z^2}^1 d_{yz}^1$. This state is of higher energy and is represented as 3T_1 . If both the electrons are excited to t_2 orbitals, the electronic configuration becomes $e^0 t_2^2$. Corresponding to this electronic configuration, there are three ways of arrangement of two electrons in any of the three orbitals of t_2 orbitals: $d_{xy}^1 d_{yz}^1$ or $d_{yz}^1 d_{zx}^1$ or $d_{xy}^1 d_{zx}^1$. Therefore, this state is once again is triply degenerate and is represented as ${}^3T_1(P)$. This state is of highest energy.

It has been seen that the order of energies of these states 3A_2 , 3T_2 , 3T_1 is reverse of the energies of ${}^3A_{2g}$, ${}^3T_{2g}$ and ${}^3T_{1g}$ for d^2 -octahedral complexes.

The terms having same spin multiplicity arising for d^2 -configuration are 3F and 3P . 3F is the ground state term. The P state does not split in a complex but 3F state splits into 3A_2 , 3T_2 and 3T_1 states in tetrahedral complex as shown in Figure 5.34.

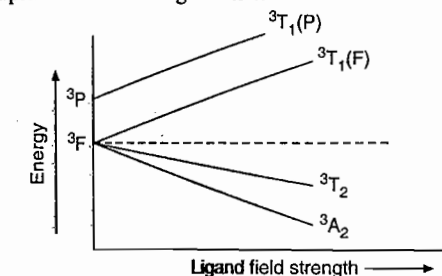
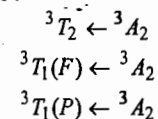

Figure 5.34 Energy diagram for d^2 -tetrahedral complex.

Three possible transitions are:



Electronic Spectra of d^8 -Octahedral Complexes

In d^8 -octahedral complexes, the d -orbitals split into t_{2g} (lower energy) and e_g (higher energy) orbitals. Thus, in ground state the electronic configuration is $t_{2g}^6 e_g^2$. There is only one electronic arrangement for this electronic configuration i.e., $t_{2g}^6 d_{x^2-y^2}^1 d_{z^2}^1$, and the ground state term corresponding to this configuration is represented as ${}^3A_{2g}$.

In a d^8 -octahedral complex two holes may be considered in e_g orbitals as shown in Figure 5.35.

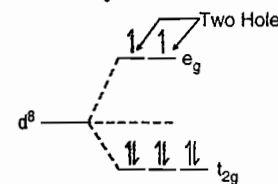

Figure 5.35

When an electron from any of the t_{2g} orbitals is excited to any one of the e_g orbitals, the electronic configuration becomes $t_{2g}^5 e_g^3$. Now there will be two holes one in t_{2g} and one in e_g orbitals. Corresponding to this electronic configuration, there are two triply degenerate states. The lower energy

state will arise when two holes occupy the orbitals as far apart as possible. This state is represented as ${}^3T_{2g}$. The holes may be present either in d_{xy} or d_{yz} $d_{x^2-y^2}$ or d_{zx} $d_{x^2-y^2}$ orbitals giving rise to lesser repulsions between two holes because two holes occupy more space in x , y and z -directions. Holes are effected in the opposite way as compared to electrons. There is another triply degenerate arrangement of two holes in which the two holes occupy the orbitals which are closer together. The holes may be present in either d_{xy} $d_{x^2-y^2}$ or d_{yz} d_{z^2} or d_{zx} d_{z^2} orbitals. This is of higher energy and is represented as ${}^3T_{1g}$.

When both the electrons are excited, the electronic configuration becomes $t_{2g}^4 e_g^4$. Now two holes are present in any of the two t_{2g} orbitals either in d_{xy} d_{yz} or d_{yz} d_{zx} or d_{xy} d_{zx} orbitals. Therefore, this state is triply degenerate and is represented as ${}^3T_{1g}(P)$. Since double excitation requires higher energy, therefore, ${}^3T_{1g}$ state is of highest energy state. There are four energy states including ground state. Thus, there are three transitions. The transitions of holes is similar to electronic transitions.

The terms having same multiplicity arising for d^8 -configuration are 3F , 3P . The 3F state is the ground state. In octahedral complex 3F term splits into ${}^3A_{2g}$, ${}^3T_{2g}$ and ${}^3T_{1g}$ as shown in Figure 5.36. The term 3P does not split but it transforms into ${}^3T_{1g}(P)$ state.

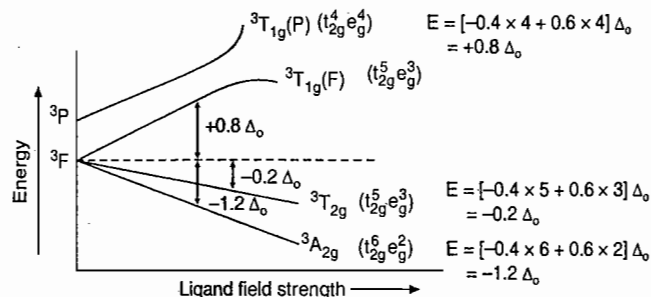
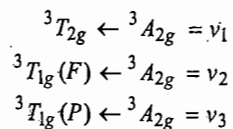

Figure 5.36 Orgel diagram for d^8 octahedral complex.

When ligand field strength increases, there will be bending of ${}^3T_{1g}(F)$ and ${}^3T_{1g}(P)$ lines because these states are of same symmetry and there is inter-electronic repulsion (or mixing of two T_{1g} states). This electronic repulsion lowers the energy of lower state and increases energy of the higher state. Thus, due to inter-electronic repulsion the two T_{1g} states do not cross. This is called non-crossing rule.

Electronic spectra of octahedral Ni(II), d^8 complexes usually consist of three bands according to the following transitions:



The lowest energy transition i.e., ${}^3T_{2g} \leftarrow {}^3A_{2g}$ gives the value of Δ_o .

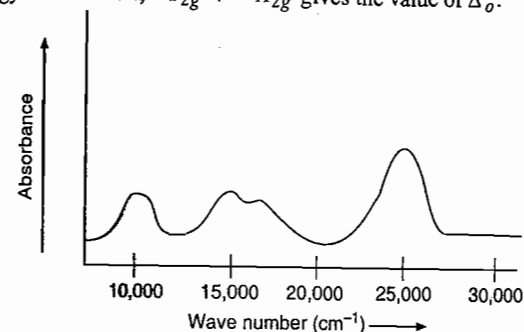

Figure 5.37 Absorption spectrum of $[\text{Ni}(\text{H}_2\text{O})_6]^{2+}$ ion.

For $[\text{Ni}(\text{H}_2\text{O})_6]^{2+}$ complex three absorption bands are observed at 8700 cm^{-1} , 14500 cm^{-1} and 25300 cm^{-1} . Lowest transition i.e., ${}^3T_{2g} \leftarrow {}^3A_{2g}$ gives the value of Δ_o because ${}^3T_{2g} \leftarrow {}^3A_{2g}$ transition $= -0.2 \Delta_o - (-1.2 \Delta_o) = \Delta_o$.

Therefore, Δ_o for $[\text{Ni}(\text{H}_2\text{O})_6]^{2+}$ is 8700 cm^{-1} .

Because of Jahn-Teller distortion in excited state the middle peak is broad (overlapping of two splitting peak).

Electronic Spectra for d^8 -Tetrahedral Complexes

For d^8 -metal ion in tetrahedral fields, the splitting of the free ion ground state term is the inverse of its splitting in octahedral fields as shown in the Figure 5.38.

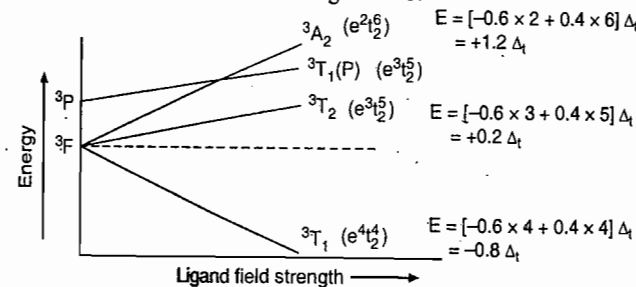
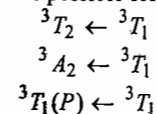

Figure 5.38 Orgel diagram for d^8 tetrahedral complex.

The following three transition are possible for d^8 -tetrahedral complexes:



Corresponding to these transitions, three relatively intense bands are expected. For $[\text{NiCl}_4]^{2-}$ two bands are observed at 7549 cm^{-1} , $14250\text{-}15240 \text{ cm}^{-1}$ as shown in Figure 5.39.

$$\text{Since } 2.0 \Delta_o = 7549 \text{ cm}^{-1} \quad ({}^3A_2 \leftarrow {}^3T_1)$$

$$\therefore \Delta_o = \frac{7549}{2.0} = 3774 \text{ cm}^{-1}$$

The band appears at $14250\text{--}15240 \text{ cm}^{-1}$ is due to Jahn-Teller distortion.

The ${}^3T_2 \leftarrow {}^3T_1$ transition shows an absorption band at 3400 cm^{-1} but it is not observed in visible region because it lies in infra red region.

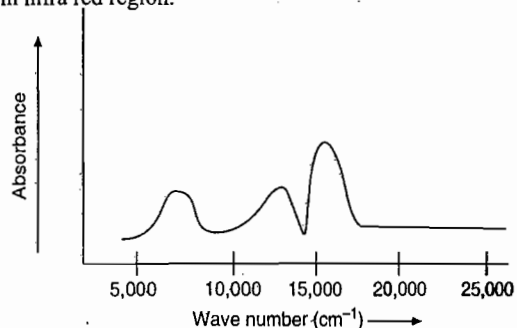

Figure 5.39 Spectrum of NiCl_2 complex ion

Electronic Spectra of d^7 -High Spin Octahedral Complexes

The free ion ground state term for $\text{Co}^{2+} (d^7)$ is 4F and its other term with same spin multiplicity of higher energy is 4P . In high spin octahedral complexes the splitting of 4F state is same as for d^2 -octahedral complexes. The 4F term splits into ${}^4T_{1g}$, ${}^4T_{2g}$ and ${}^4A_{2g}$ states as shown in the Figure 5.40.

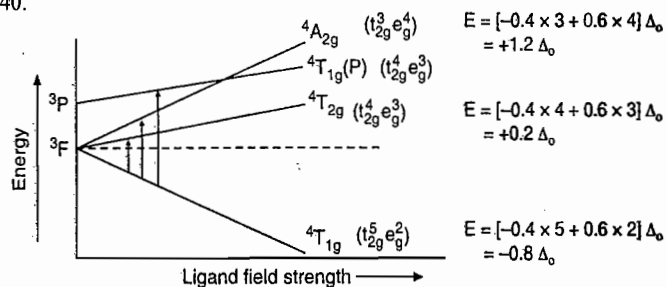

Figure 5.40 Crystal field diagram for d^7 -high spin complex

For crystal of KCoF_3 in which Co^{2+} ion is surrounded octahedrally by six F^- ligands.

There are three absorption bands at 7150 cm^{-1} , 15200 cm^{-1} and 19200 cm^{-1} corresponding to three transitions.

$${}^4T_{2g} \leftarrow {}^4T_{1g}, \quad \nu_1 = 7150 \text{ cm}^{-1}$$

$${}^4A_{2g} \leftarrow {}^4T_{1g}, \quad \nu_2 = 15200 \text{ cm}^{-1}$$

$${}^4T_{1g}(P) \leftarrow {}^4T_{1g}, \quad \nu_3 = 19200 \text{ cm}^{-1}$$

Lower transition (${}^4T_{2g} \leftarrow {}^4T_{1g}$) may give the value of Δ_o because ${}^3T_{2g} \leftarrow {}^3T_{1g}$ transition (ν_1) is $= 0.2 \Delta_o - (-0.8 \Delta_o) = \Delta_o$.

But this does not allow for the configuration interaction (binding of lines) between ${}^4T_{1g}(F)$ and ${}^4T_{1g}(P)$ states. In this case separation between first (ν_1) and the second band (ν_2) gives the value of Δ_o because this is not effected by configuration interaction.

$$\nu_2 - \nu_1 = \Delta_o$$

Therefore,

$$\begin{aligned} \Delta_o &= 15200 - 7200 \\ &= 8000 \text{ cm}^{-1} \end{aligned}$$

Absorption spectra of K_3CoF_3 is shown in Figure 5.41.

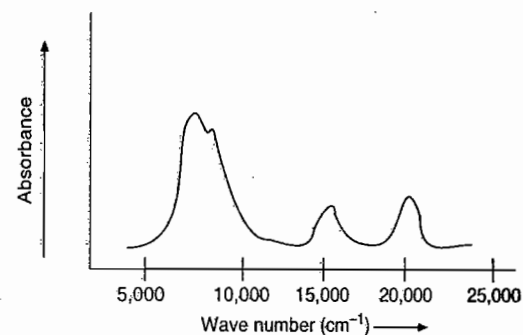

Figure 5.41 Absorption spectrum of K_3CoF_3

Absorption Spectrum of $[\text{Co}(\text{H}_2\text{O})_6]^{2+}$ Complex Ion

In $[\text{Co}(\text{H}_2\text{O})_6]^{2+}$ complex ion, the spectrum usually consists of a weak band in near infrared region at 8000 cm^{-1} . This band is assigned as $\nu_1 = {}^4T_{2g}(F) \leftarrow {}^4T_{1g}(F)$. An another band appears at approximately 20000 cm^{-1} . This band is considered to be comprising three overlapping peaks. This band has three peaks at 16000 cm^{-1} , 19400 cm^{-1} and 21600 cm^{-1} . Two peaks observed at 16000 cm^{-1} and 19400 cm^{-1} correspond to ${}^4A_{2g} \leftarrow {}^4T_{1g}$ and ${}^4T_{1g}(P) \leftarrow {}^4T_{1g}$ transitions. Since these two transitions are near the cross over point of ${}^4A_{2g}$ and ${}^4T_{1g}(P)$ states, therefore, two peaks overlap one another forming a shoulder in the spectrum.

The extra band which appears at 21600 cm^{-1} is due to spin orbit coupling or transition to another state of lower spin multiplicity.

In some cases ν_2 is not observed but the fine peaks arise from splitting of term due to spin orbit coupling or Jahn-Teller distortion in excited state.

The spectrum of $[\text{Co}(\text{H}_2\text{O})_6]^{2+}$ is shown in Figure 5.42.

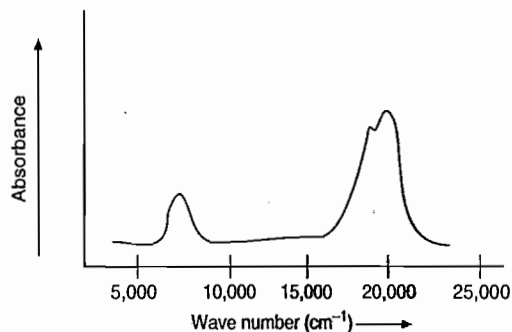

Figure 5.42. Electronic spectrum of $[\text{Co}(\text{H}_2\text{O})_6]^{2+}$ complex ion.

Electronic Spectra of d^7 -tetrahedral Complexes

In a tetrahedral complex ion, say $[\text{CoCl}_4]^{2-}$ the splitting of free ion ground term is the reverse of that in octahedral complexes so that for d^7 -ion in tetrahedral complex 4A_2 is of lowest energy. There are three possible transitions:

$${}^4T_2 \leftarrow {}^4A_2, \quad \nu_1 = 3300\text{ cm}^{-1} \quad (\text{IR region})$$

$${}^4T_1(F) \leftarrow {}^4A_2, \quad \nu_2 = 5500\text{ cm}^{-1} \quad (\text{IR region})$$

$$\text{and} \quad {}^4T_1(P) \leftarrow {}^4A_2, \quad \nu_3 = 14700\text{ cm}^{-1} \quad (\text{Visible region})$$

Only one band corresponding to ${}^4T_1(P) \leftarrow {}^4A_2$ appears in visible region at 14700 cm^{-1} (ν_3).

Two bands corresponding to ${}^4T_2 \leftarrow {}^4A_2$ and ${}^4T_1(F) \leftarrow {}^4A_2$ appear at 3300 cm^{-1} (ν_1) and 5500 cm^{-1} (ν_2) respectively. These two bands are in infrared region. The electronic transition are shown in Figure 5.43.

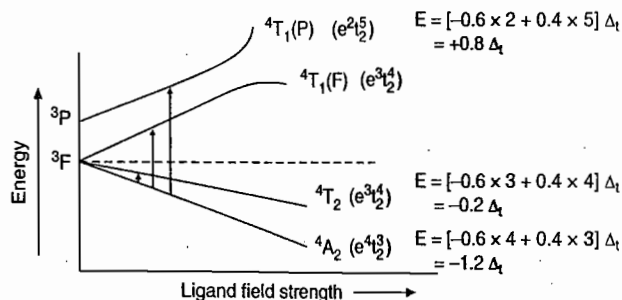

Figure 5.43. Orgel diagram for d^7 tetrahedral complex.

Absorption spectrum of $[\text{CoCl}_4]^{2-}$ complex ion is shown in Figure 5.44.

For $[\text{CoCl}_4]^{2-}$ ion, Δ_t is the energy difference between 4A_2 and 4T_2 states.

$$\Delta_t = [-0.2 - (-1.2)]\Delta_t = 3300\text{ cm}^{-1}.$$

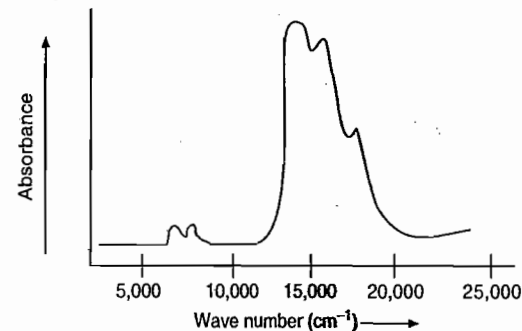

Figure 5.44. Spectrum of $[\text{CoCl}_4]^{2-}$ ion.

Tetrahedral complex $[\text{CoCl}_4]^{2-}$ is more intensely blue in colour whereas the high spin complexes of Co^{2+} ion are of faint colour.

The intense colour of $[\text{CoCl}_4]^{2-}$ tetrahedral complex ion is due to:

- $d-d$ transition is Laporte partly allowed *i.e.*, there is some $p-d$ mixing.
- $d-d$ transitions are spin allowed.

The faint colour of high spin complexes of Co^{2+} ion is due to:

- $d-d$ transition is Laporte forbidden
- $d-d$ transitions are spin allowed.

Electronic Spectra of d^3 -Octahedral Complexes

In d^3 -octahedral complexes the d -orbitals split into t_{2g} (lower energy) and e_g (higher energy) orbital. Therefore, in ground state the electronic configuration is $t_{2g}^3 e_g^0$ and there are two holes in e_g orbitals (Figure 5.45).

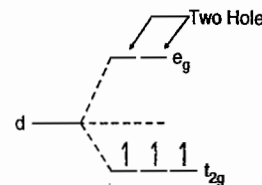

Figure 5.45.

There is only one electronic arrangement corresponding to this electronic configuration *i.e.*, $t_{2g}^3 e_g^0$ ($d_{xy}^1 d_{yz}^1 d_{zx}^1 e_g^0$). Therefore, this arrangement is electronically non-degenerate and can be represented as ${}^3A_{2g}$.

This case is similar to d^8 -octahedral complex. When an electron is excited to any one of the e_g orbitals, the electronic configuration becomes $t_{2g}^2 e_g^1$. Now there are two holes, one in t_{2g} and one in e_g orbitals. There are two triply degenerate arrangements of holes corresponding to this electronic configuration. The lower energy state will arise when two holes occupy the orbitals as far apart as possible. Therefore, the two holes may be present either in $d_{xy} d_{z^2}$ or $d_{yz} d_{x^2-y^2}$ or $d_{zx} d_{x^2y^2}$. Thus, this state is triply degenerate and is represented as $^3T_{2g}$.

There is another triply degenerate arrangement of two holes in which two holes occupy the orbitals which are closer together. The holes may be present either in $d_{xy} d_{x^2-y^2}$ or $d_{yz} d_{z^2}$ or $d_{zx} d_{z^2}$ orbitals. This state is of higher energy and is represented as $^3T_{1g}$.

When two electrons are excited to e_g orbitals the electronic configuration becomes $t_{2g}^1 e_g^2$. Now two holes are present in two t_{2g} orbitals either in $d_{xy} d_{yz}$ or $d_{yz} d_{zx}$ or $d_{xy} d_{zx}$ orbitals. Thus, this state is triply degenerate and have highest energy. This state is represented as $^3T_{1g}(P)$.

Therefore, there are three transitions of holes from ground states to three other excited states. Transition of holes is similar to electronic transition.

The terms for d^3 -metal cation having same spin multiplicity ($= 4$) are 4F and 4P . For d^3 -configuration 4F term is the ground state and 4P term is of higher energy. In octahedral complex 4F term splits into $^4T_{1g}$, $^4T_{2g}$ and $^4A_{2g}$ states as show in Figure 5.46. The 4P term does not split but transforms into $^4T_{1g}(P)$ state.

When ligand field strength increases, there will be bending of $^4T_{1g}(F)$ and $^4T_{1g}(P)$ lines because these have same symmetry and there is electron-electron repulsion (mixing of two $^4T_{1g}$ states). This mixing lower the energy of lower state, $^4T_{1g}(F)$ and increase the energy of higher state, $^4T_{1g}(P)$ in equal amount. Therefore, due to mixing the two T_{1g} states do not cross each other.

There are three possible spin allowed $d-d$ transitions.

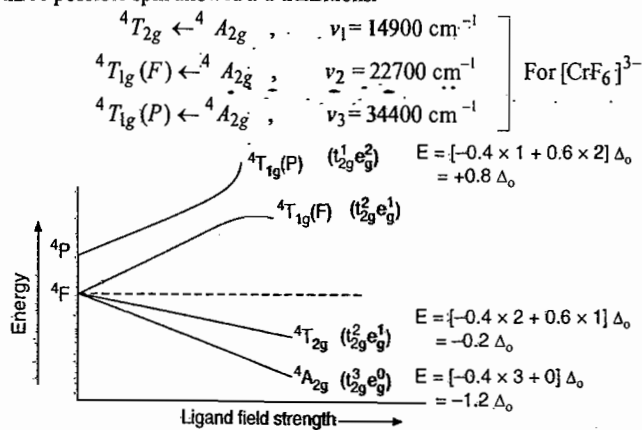

Figure 5.46. Energy level diagram for d^3 -octahedral complex.

These transitions are responsible for three absorbance bands in electronic spectrum of d^3 -octahedral complexes. For $[\text{CrF}_6]^{3-}$ three absorption bands occur at 14900 cm^{-1} , 22700 cm^{-1} and 34400 cm^{-1} .

One $d-d$ transition with lowest energy ($^4T_{2g} \leftarrow ^4A_{2g}$) is a direct measure of the crystal field splitting Δ_o or $10 Dq$.

$$\Delta_o = -0.2\Delta_o - (-1.2\Delta_o) = 14900 \text{ cm}^{-1}. (\nu_1)$$

Two bands are observed in visible region but third band corresponding to ν_3 is weak and is observed in UV-region. Electronic spectrum for $[\text{CrF}_6]^{3-}$ is shown in Figure 5.47.

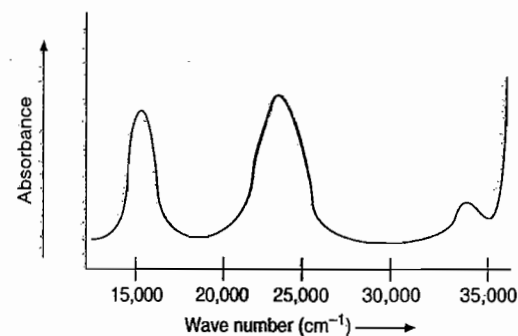

Figure 5.47. Absorbance spectrum for $[\text{CrF}_6]^{3-}$ complex.

The splitting of 4F and 4P terms including mixing of two states [$^4T_{1g}(F)$ and $^4T_{1g}(P)$] is shown in Figure 5.48.

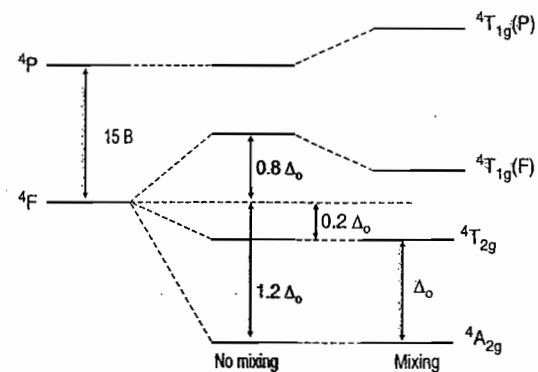

Figure 5.48. Splitting of 4F and 4P terms.

In $[\text{Cr}(\text{H}_2\text{O})_6]^{3+}$ complex ion three bands appear at 17400 cm^{-1} , 24700 cm^{-1} and 37800 cm^{-1} . The high energy band 37800 cm^{-1} is weak and is assigned due to promotion of two holes and is hidden by charge transfer band.

Cr^{3+} ion does not form tetrahedral complexes, therefore, spectra of Cr^{3+} ion in tetrahedral complex can not be interpreted here.

Combined Orgel diagram for d^2, d^3, d^7 and d^8 -octahedral and tetrahedral complex is shown in Figure 5.49.

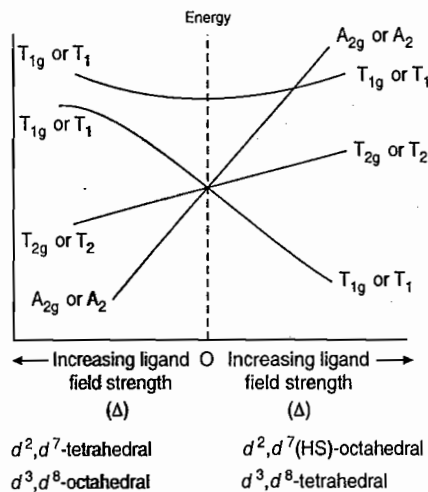

Figure 5.49 Combined Orgel diagram for d^2, d^3, d^7 and d^8 -octahedral and tetrahedral complexes

Electronic Spectra of d^5 -High Spin Octahedral Complexes

In high spin octahedral complexes of d^5 -metal ions-like, $[\text{Mn}(\text{H}_2\text{O})_6]^{2+}$, $[\text{FeF}_6]^{3-}$ d -orbitals split into t_{2g} (lower energy) and e_g (higher energy) orbitals and the electronic configuration becomes $t_{2g}^3 e_g^2$.

In these complexes there are five unpaired electrons with parallel spins. Any $d-d$ transition involves reversal of spins. Thus, $d-d$ transitions are spin forbidden. Also $d-d$ transitions are Laporte forbidden because of presence of centre of symmetry. Therefore, these complexes are very faint coloured or colourless. $[\text{Mn}(\text{H}_2\text{O})_6]^{2+}$ is pale pink and $[\text{FeF}_6]^{3-}$ is pale violet coloured. The ground state term for d^5 -free metal ion is 6S which does not split in octahedral field but transforms into $^6A_{1g}$. There are no excited states of the same spin multiplicity ($=6$) and, therefore, there will be no spin allowed transitions.

There are 11 excited states for d^5 -free metal ion but none of them have spin multiplicity equal to six. Among these 11 excited states four states have spin multiplicity of 4 and these states are 4P , 4D , 4F and 4G . In high spin octahedral field these states split to give total number of 10 excited states which are $^4T_{1g}(P)$, $^4T_{2g}(D)$, $^4E_g(D)$, $^4T_{1g}(F)$, $^4T_{2g}(F)$, $^4A_{1g}(G)$, $^4E_g(G)$, $^4T_{1g}(G)$ and

$^4T_{2g}(G)$. The $d-d$ transition to these states involve the reversal of only one spin. The other states are doublets and $d-d$ transition to these states is doubly spin forbidden and are not observed. There may be ten $d-d$ transitions to the ten quartets but these are very weak. The absorption spectrum for $[\text{Mn}(\text{H}_2\text{O})_6]^{2+}$ is shown in Figure 5.50. The $^4A_{1g}$ and 4E_g peaks are unresolved in the spectrum. The molar absorbance is $0.02 - 0.03\text{ L mol}^{-1}\text{ cm}^{-1}$.

In Orgel diagram of $[\text{Mn}(\text{H}_2\text{O})_6]^{2+}$, the $^6A_{1g}$ line is horizontal. Also the $^4E_g(G)$, $^4E_g(D)$, $^4A_{2g}(F)$ and $^4A_{1g}(G)$ lines are also parallel to $^6A_{1g}$ lines i.e., there is no change in energy due to change in ligands and vibrations. Thus, transitions to these states give rise to sharp peaks but peaks are extremely weak. The $^4T_{1g}(G)$ and $^4T_{2g}(G)$ lines are not parallel to $^6A_{1g}$ line because their energy is changed with change in ligands and thus transitions to these states provide broad peaks.

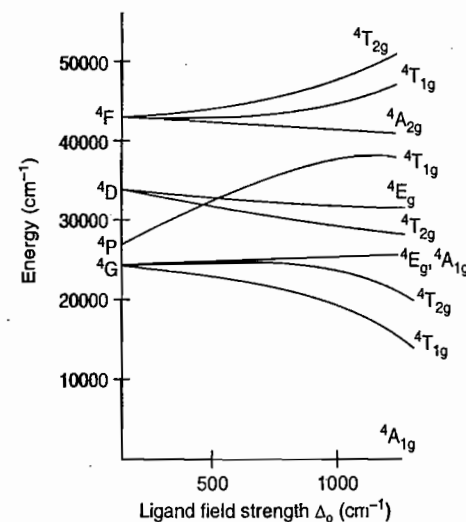

Figure 5.50 Orgel diagram for d^5 -high spin complex

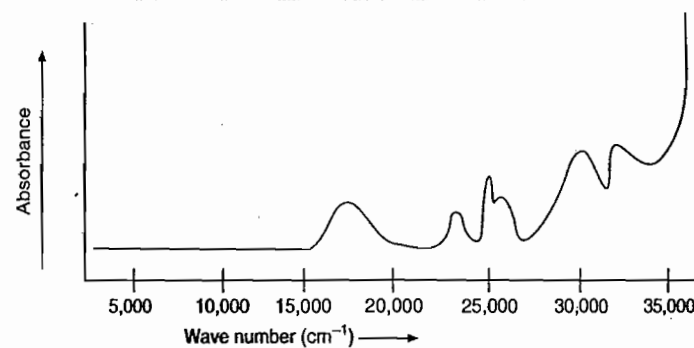

Figure 5.51 Spectrum of $[\text{Mn}(\text{H}_2\text{O})_6]^{2+}$

Electronic Spectra of d^5 -Tetrahedral Complexes

In tetrahedral complexes of Mn^{2+} ions, for examples, $[MnCl_4]^{2-}$, $[MnBr_4]^{2-}$ the d -orbitals split into e (lower energy) and t_2 (higher energy) orbitals giving rise to $e^2 t_2^3$ -configuration. Since tetrahedral complexes lack centre of symmetry, therefore, $d-d$ transitions are Laporte partly allowed but these transitions are spin forbidden. Therefore, these transitions in tetrahedral complexes are weaker. However $d-d$ transitions in tetrahedral complexes are still stronger than in high spin octahedral complexes because (i) $d-d$ transitions are spin forbidden in both tetrahedral and high spin octahedral complex (ii) $d-d$ transitions are Laporte partly allowed in tetrahedral complexes but Laporte forbidden in high spin octahedral complexes.

Racah Parameters and Nephelauxetic Series

Different terms of a configuration have different energies due to inter-electronic repulsion. The inter-electronic repulsion (or mixing) which causes the bending of the lines is expressed in terms of the Racah parameters B and C which can be calculated from linear combinations of coulomb and exchange integrals. These parameters are empirical quantities and are obtained from the spectra of free ions in gas phase. For the terms of same spin multiplicity, the difference in energy is only the function of B . For example, the difference in energy between free ion ground state term F and an excited state term P of same multiplicity for d^2, d^3, d^7 and d^8 -metal ions is $15B$. However, both parameters B and C are necessary for terms with different multiplicities, for example, in the $Cr^{3+}(d^3)$ ion the difference between energy between 4F and 2G is $4B + 3C$. For most transition metal ions value of B lie in the range of $700 - 1100 \text{ cm}^{-1}$. C is equal to $\sim 4B$.

The value of B , labeled as B' for a complex is always less than that of the free ion because of delocalization of metal electrons in molecular orbitals that encompass both the metal and ligands. Due to delocalization of electrons inter-electronic repulsion is decreased. The delocalization increases the average separation of d -electrons and hence reduces their mutual repulsion. The reduction of B from its free ion value is called nephelauxetic effect or cloud expanding effect. The nephelauxetic effect is represented in terms of nephelauxetic parameter (β) which is given by:

$$\beta = \frac{B_{\text{Complex}}}{B_{\text{Free ion}}} = \frac{B'}{B}$$

The value of β is always less than 1 and it decreases with increasing delocalization. In general $B' = \sim 0.8B$.

For a given metal ion, value of β decreases as follows:

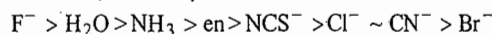

This series is called nephelauxetic series.

Lower the value of β , more will be the delocalization of d -electrons and there will be a significant covalent character in the complex.

If all the three transitions are observed then the value of B' can be calculated from the following equation:

$$15B' = \nu_3 + \nu_2 - 3\nu_1$$

Where wave number (in cm^{-1}) increases in the order $\nu_1 < \nu_2 < \nu_3$.

CHARGE TRANSFER SPECTRA

Charge transfer transition is the transfer of an electron between orbitals that are centred on different atoms. Unlike $d-d$ transitions, charge transfer transitions are Laporte and spin allowed *i.e.*,

$$\Delta l = \pm 1 \quad \text{and} \quad \Delta S = 0$$

Thus, charge transfer transitions give rise to more intense (strong) absorptions. When these transitions occur in visible region, the compound show intense colour. A charge transfer transition may be regarded as an internal redox process. Charge transfer transitions may be classified in four ways:

- (1) Ligand to Metal Charge Transfer (LMCT)
- (2) Metal to Ligand Charge Transfer (MLCT)
- (3) Inter Valence Charge Transfer
- (4) Intra Ligand Charge Transfer

(1) Ligand to Metal Charge Transfer (LMCT)

If the transfer of an electron takes place from the ligand to metal, then charge transfer is called ligand to metal charge transfer.

Conditions for LMCT:

- (i) Metal should be in high oxidation state so that it has high ionization energy, smaller size and vacant orbitals at low energies.
- (ii) Ligands should have lone pair of electrons of relatively high energy and low electron affinity.

For example, In $KMnO_4$, Mn is in +7 oxidation state and have all the $3d$ -orbitals vacant. Mn^{7+} ion is surrounded tetrahedrally by four oxide ions. All oxide ions have filled $2p$ -orbitals. There is transfer of an electron from filled $2p$ -orbitals of oxide ion to vacant d -orbitals of Mn^{7+} ion. Since p -orbitals are ungerade and d -orbitals are gerade, therefore, electron transition from p -orbitals of O^{2-} to d -orbitals of Mn^{7+} ion is Laporte allowed *i.e.*, $\Delta L = \pm 1$ and also there is no change in spin multiplicity during electronic transition. Therefore, transfer of an electron is Laporte and spin allowed. Therefore, $KMnO_4$ is intensely purple.

Colour and orbitals involved in ligand to metal charge transfer of some compound are given in Table 5.5.

Energy required to transferred an electron from ligand to metal depends upon the lowest unoccupied molecular orbital (LUMO) of the metal cation and the highest occupied molecular orbital (HOMO) of the ligand.

Table 5.5 Colour and Orbitals Involved in LMCT of Compounds

Compound	Colour	Orbitals Involved
CdS	Yellow	$Cd^{2+}(4s) \leftarrow S^{2-}(\pi p)$
HgS	Red	$Hg^{2+}(6s) \leftarrow S^{2-}(\pi p)$
MnO_4^{2-}	Green	$Mn^{6+}(3d) \leftarrow O^{2-}(\pi p)$
CrO_4^{2-}	Yellow	$Cr^{6+}(3d) \leftarrow O^{2-}(\pi p)$
HgI ₂	Red	$Hg^{2+}(6s) \leftarrow I^-(\pi p)$
V_2O_5	Red	$V^{5+}(3d) \leftarrow O^{2-}(\pi p)$

$\text{Cr}_2\text{O}_7^{2-}$	Orange	$\text{Cr}^{6+}(3d) \leftarrow \text{O}^{2-}(\pi p)$
SnI_4	Orange	$\text{Sn}^{4+}(6s) \leftarrow \text{I}^-(\pi p)$
CrO_3	Bright Orange	$\text{Cr}^{6+}(3d) \leftarrow \text{O}^{2-}(\pi p)$
PbCrO_4	Yellow	$\text{Cr}^{6+}(3d) \leftarrow \text{O}^{2-}(\pi p)$
PbO	—	$\text{Pb}^{2+}(5s) \leftarrow \text{O}^{2-}(\pi p)$
FeBr_3	Red Brown	—
Cu_2O	Red	—
CuI	Brown	—
Ochres (Oxides of iron)	Red and Yellow	$\text{Fe}(3d) \leftarrow \text{O}^{2-}(\pi p)$
$\text{Fe}(\text{SCN})_3$	Red	$\text{Fe}^{3+}(3d) \leftarrow \text{SCN}^-(\pi p)$

For examples, (i) energy required for electron transfer from πp -orbital of oxide ion to metal ion in soelectronic species like VO_4^{3-} , CrO_4^{2-} and MnO_4^- decreases in the order :

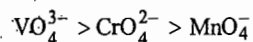

On moving from VO_4^{3-} to CrO_4^{2-} to MnO_4^- size of metal cation decreases in the order $^{5+} > \text{Cr}^{6+} > \text{Mn}^{7+}$ because in this direction effective nuclear charge increases and energy of acceptor orbitals (d -orbitals) decreases. Therefore, energy of charge transfer decreases. Hence energy of charge transfer decreases in the following order :

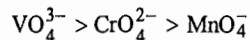

Therefore, VO_4^{3-} is colourless, CrO_4^{2-} is yellow and MnO_4^- is purple.

Another consequence of the energy difference between LUMO centred on metal ion and HOMO centred on ligand is that the metal oxygen bond distance decreases in the order :

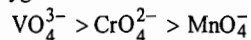

On moving from $3d$ to $4d$ to $5d$ -series of transition metals in a group, for a given oxidation state, size of metal cation increases and energy of LUMO (*i.e.*, vacant d -orbitals) centred on metal cation increases and, therefore, energy required to transfer of an electron from HOMO of oxide ion to LUMO of metal cation in tetra oxo-anions increases on moving down the group.

+5	+6	+7	Increase order of energy of LMCT
VO_4^{3-}	CrO_4^{2-}	MnO_4^-	
+5	+6	+7	
NbO_4^{3-}	MoO_4^{2-}	TcO_4^-	Decreasing order of energy of LMCT
+5	+6	+7	
TaO_4^{3-}	WO_4^{2-}	ReO_4^-	

Decreasing order of energy of LMCT

Tetra oxo-anions of $4d$ and $5d$ -series transition metals are colourless because energy difference between $2p$ - of oxide ion and $4d$ - and $5d$ -orbitals of transition metals is very large and electron transfer from πp -orbitals of oxide to d -orbitals of metal requires a high energy which lies in UV-region.

In $[\text{Cr}(\text{NH}_3)_6]^{3+}$ complex ion two $d-d$ bands of lower energy and one band due to charge transfer appears as a shoulder on the high energy side of one of the $d-d$ bands in UV-region, when one NH_3 ligand is replaced by X^- ($X = \text{Cl}, \text{Br}, \text{I}$), the energy of two $d-d$ bands and one charge transfer band decreases because symmetry is reduced from Oh to C_{4v} . These bands appear at progressively lower energy (wave number) on going from Cl to Br to I . Similar spectra can be obtained for $[\text{Co}(\text{NH}_3)_5 X]^{2+}$.

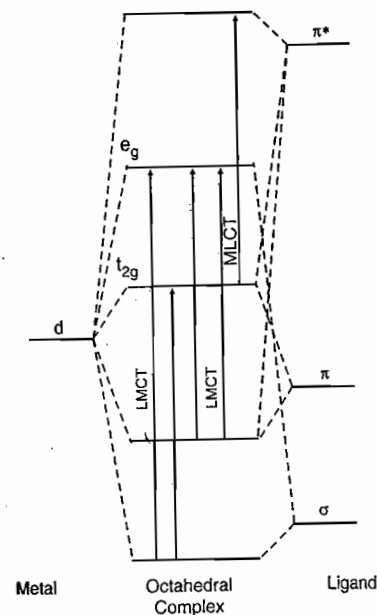

Figure 5.52

(2) Metal to Ligand Charge Transfer (MLCT)

In MLCT, an electron migrates from metal to ligand. MLCT are favoured in complexes in which :

- (i) Metal have low oxidation state.
- (ii) Metal d -orbitals are filled.
- (iii) Metal d -orbitals are of relatively high in energy.
- (iv) Ligand have empty π -antibonding orbitals.

MLCT mainly occurs with the ligands having π^* orbitals such as CO , CN^- , SCN^- , pyridine, bipyridine, *o*-phenanthroline, pyrazine, dithioline, NO etc.

In an octahedral complex when t_{2g} and e_g^* orbitals (both belong to metal) are occupied, two MLCT bands $\pi^* \leftarrow t_{2g}$ and $\pi^* \leftarrow e_g^*$ are observed. (π^* is the vacant orbital of the ligand). If either t_{2g} or e_g^* orbitals are occupied, then only one charge transfer bond $t \pi^* \leftarrow t_{2g}$ or $\pi^* \leftarrow e_g^*$ is observed.

The spectra of Fe (II) with ligands containing the α -diimine unit have intense charge transfer bands caused by the transfer of electron from metal t_{2g} orbitals to π^* -orbitals of the α -diimine group.

Fe(II) complexes (C.N = 6) containing tetramine macrocyclic ligand (TIM) have intense colours due to MLCT.

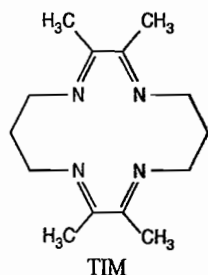

The compounds and their colours arising from MLCT are shown in Table 5.6.

Table 5.6

Compound	Colour
$K_4[Fe(CN)_6]$	Yellow
$K_3[Fe(CN)_6]$	Red
$[Fe(Phen)_3]^{3+}$	Blue
$[Fe(acac)_3]$	Red

(3) Intervalence Transitions (or Metal to Metal Charge Transfer Transitions)

In these transitions an electron gets excited from the valence shell of one atom to valence shell of the other atom. Electron transfer takes place from an atom of lower oxidation state to an another atom of higher oxidation state.

For example :

- (i) Prussian blue $KFe[Fe(CN)_6]$ shows intense blue colour because of transfer of an electron from Fe^{2+} to Fe^{3+} . In Prussian blue, Fe^{2+} ion is octahedrally coordinated with C atom of the CN^- ligands and Fe^{3+} is octahedrally coordinated with N atom of CN^- ligands. Thus, an electron transfer takes place through bridging cyanide ligands.

- (ii) Another example of intervalence charge transfer is Creutz-Taube ion,

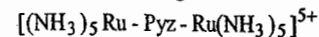

where pyz is bridging pyrazine ligand.

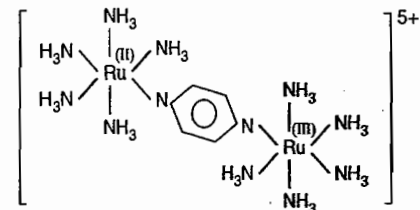

Figure 5.53

In this compound electron transfer occurs from Ru(II) to Ru(III) through pyrazine bridging ligand and give intense colour.

- (iii) Red lead (Pb_3O_4) contains Pb(II) and Pb(IV). Due to electron transfer from Pb(II) to Pb(IV), it gives intense red colour.

(4) Intra Ligand Charge Transfer

Some ligands (organic ligands) behave as chromophore and the chromophore nature is responsible for colour. There are four electronic transitions $\sigma \rightarrow \sigma^*$, $\pi \rightarrow \pi^*$, $n \rightarrow \pi^*$ or $n \rightarrow \sigma^*$ within a chromophore. When such a ligand is coordinated with metal ion/atom, energy of absorption changes.

Spectra of Compounds with Metal-Metal Bonds

The compounds which contains metal-metal bonds give intense colour. The colour is due to $\sigma \rightarrow \sigma^*$, $\pi \rightarrow \pi^*$ and $\delta \rightarrow \delta^*$ transitions. For example, $Re_2Cl_8^{2-}$ is royal blue, $Mo_2Cl_8^{4-}$ is red. Colour of compounds having quadruple bonds (like $Re_2Cl_8^{2-}$, $Mo_2Cl_8^{4-}$) is due to $\delta \rightarrow \delta^*$ transition. The metal carbonyls containing single $M-M$ bonds are often intensely coloured due to metal $\sigma \rightarrow \sigma^*$ transitions. For example, $Mn_2(CO)_{10}$ is bright yellow, $Fe_2(CO)_9$ is gold and $Co_2(CO)_8$ is purple black.

TANABE-SUGANO DIAGRAMS

Orgel diagrams are useful in the interpretation of spectra of spin allowed transitions of high spin octahedral and tetrahedral complexes. But on the other hand Tanabe-Sugano diagram are useful in the interpretation of spectra of both high spin and low spin complexes of $d^2 - d^8$ metal ions. In Orgel diagrams the ground and excited have same and maximum multiplicity but in Tanabe-Sugano diagrams the states of spin multiplicity lower than the ground state are also included. In Tanabe-Sugano diagrams, the energies of excited states (expressed as E/B) are plotted against ligand field strength (expressed as Δ_0/B), where B is Racah parameter, a measure of the repulsion between the terms of same spin multiplicity. For example, for d^2 , the energy difference between 3F and 3P is $15B$. Because $C \sim 4B$, terms with energies that depend on both B and C can be plotted on the same diagram. The ground state (lowest energy state) is always plotted along the horizontal axis (abscissa) and the energies of excited states are plotted relative to the ground state.

For different iso-electronic ions (same electronic configuration) like Ti^{2+} and V^{3+} with d^2 configuration, the values of B are different. Also the value of B' depends upon ligand field strength (Δ_o), therefore, by plotting E/B against Δ_o/B . One Tanabe-Sugano diagram may be used for different iso-electronic metal ions. When the ligand field strength increases, the lines of same symmetry never cross each other but bent far apart from each other due to mixing (repulsion) of terms. This is called non-crossing rule.

Calculation of Δ_o and B using Tanabe-Sugano diagrams

- (i) A T-S diagram for d^2 -octahedral complexes is shown in Figure 5.54. Note that there is no fundamental difference between weak and strong field. The T-S diagrams of d^2 , d^3 and d^8 are simplified by showing only the energy levels of the states of maximum spin multiplicity because these are involved in observable spectral bands.

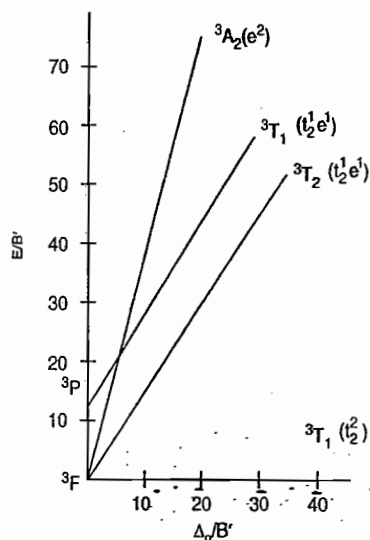
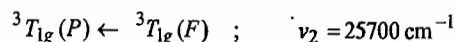
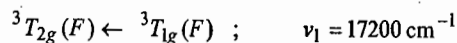

Figure 5.54. T-S diagram for d^2 octahedral complex.

Electronic spectra of $[V(H_2O)_6]^{3+}$ ion show two bands corresponding to the transitions.



The third band is of high energy and weak intensity because of two electrons transition.

The ratio of these energies is given by:

$$\frac{E_2}{E_1} = \frac{E_2/B'}{E_1/B'} = \frac{25700}{17200} = 1.5$$

By sliding a ruler along the abscissa in Figure 5.54.

The ratio of energy gaps i.e., $\frac{E_2/B'}{E_1/B'}$ is obtained at $\Delta_o/B' = 28$. At this point, the values of E_1/B' and E_2/B' are 26 and 39 respectively. Thus,

$$\frac{E_1}{B'} = \frac{17200}{B'} = 26$$

$$\text{Therefore, } B' = \frac{17200}{26} = 661 \text{ cm}^{-1}$$

Value of B' can also be calculated from

$$\frac{E_2}{B'} = \frac{25700}{B'} = 39$$

$$\text{Therefore } B' = \frac{25700}{39} \approx 659 \text{ cm}^{-1}$$

For calculation of third transition to ${}^3A_{2g}$, the value of E_3/B' corresponding to $\frac{\Delta_o}{B} = 28$ is obtained equal to 55.

$$\text{Therefore, } \frac{E_3}{B'} = 55$$

$$\begin{aligned} \text{Therefore, } E_3 &= 55 \times B' = 55 \times 659 \\ &= 36245 \text{ cm}^{-1} \end{aligned}$$

$$\text{The value of } \Delta_o = 28 \times 659 = 18452 \text{ cm}^{-1}$$

(ii) T-S diagrams for d^3 and d^8 octahedral complexes:

The T-S diagrams for d^3 and d^8 -octahedral complexes are same but these differ in the spin multiplicity of the term symbol used, for example, $[Cr(H_2O)_6]^{3+}$ and $[Ni(H_2O)_6]^{2+}$. In these cases Δ_o can also be obtained by measuring lowest energy transition, ν_1 .

The T-S diagram for d^3 and d^8 -octahedral complexes are shown in Figure 5.55(a) and 5.55(b).

The electronic spectrum of $[Cr(H_2O)_6]^{3+}$ shows three transitions:

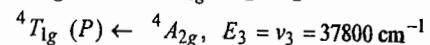
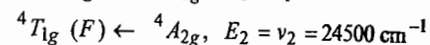
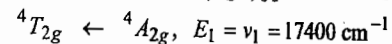

The third band arise as a shoulder due to presence of charge transfer transition. The ratio of ν_2 and ν_1 is given by:

$$\frac{\nu_2}{\nu_1} = \frac{E_2}{E_1} = \frac{E_2/B'}{E_1/B'} = \frac{24500}{17400} = 1.41$$

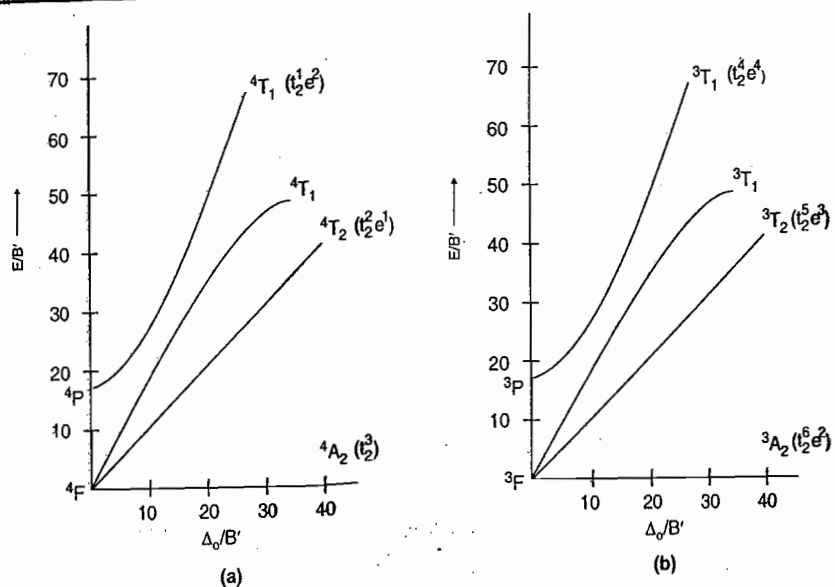

Figure 5.55 T-S diagram for (a) d^3 , (b) d^6 octahedral complexes.

Now from Figure 5.55(a), by sliding a ruler along the abscissa the ratio of energy gaps $\frac{E_2/B'}{E_1/B'}$ is

obtained at $\frac{\Delta_o}{B'} = 25$. At this point $\frac{\Delta_o}{B'} = 25$, $\frac{E_1}{B'} = 24$

Therefore, $B' = \frac{17400}{25} = 700 \text{ cm}^{-1}$

Since $\frac{\Delta_o}{B'} = 25$
 $\Delta_o = 25 \times 700$
 $= 17500 \text{ cm}^{-1}$

For calculation of third transition to ${}^4T_{1g}(P)$, the value of E_3/B' corresponding to $\frac{\Delta_o}{B'} = 25$ is obtained equal to 54.

Thus, $\frac{E_3}{B'} = 54$
 $E_3 = 54 \times B' = 54 \times 700$
 $= 37800 \text{ cm}^{-1}$

If all the three transitions are possible then value of B' can also be calculated by:

$$15B' = \nu_3 + \nu_2 - 3\nu_1 = 37800 + 24500 - 3 \times 17400$$

$$B' = 675 \text{ cm}^{-1}$$

The electronic spectrum of $[\text{Ni}(\text{H}_2\text{O})_6]^{2+}$ complex ion shows three electronic transitions:

$${}^3T_{2g} \leftarrow {}^3A_{2g}; E_1 = \nu_1 = 8500 \text{ cm}^{-1}$$

$${}^3T_{1g}(F) \leftarrow {}^3A_{2g}; E_2 = \nu_2 = 14500 \text{ cm}^{-1}$$

$${}^3T_{1g}(P) \leftarrow {}^3A_{2g}; E_3 = \nu_3 = 25300 \text{ cm}^{-1}$$

The ratio of ν_3 and ν_2 is given by

$$\frac{\nu_3}{\nu_2} = \frac{E_3}{E_2} = \frac{E_3/B'}{E_2/B'} = \frac{25300}{14500} = 1.74$$

By sliding a ruler along the abscissa in Figure 5.55 (b).

The ratio $\frac{E_3/B'}{E_2/B'}$ is obtained at $\frac{\Delta_o}{B'} = 10$

At this point $E_3/B' = 28$

$$\text{or } B' = \frac{E_3}{28} = \frac{25300}{28} = 904 \text{ cm}^{-1}$$

Since $\frac{\Delta_o}{B'} = 10$

Therefore, $\Delta_o = 10 \times 904 = 9040 \text{ cm}^{-1}$

Tanabe-Sugano Diagram for d^6 -Octahedral Complexes

The T-S diagram of d^6 -octahedral complexes (high spin and low spin) is shown in Figure 5.56.

The free ion ground state for $\text{Co}^{3+} (d^6)$ is 5D and there are various high energy states out of which 1I is important. In octahedral field 5D splits into ${}^5T_{2g}$ (ground state) and 5E_g (excited state) and 1I splits into five different states out of which the ${}^1A_{1g}$ is important. It is to be noted that ground state of high spin ($t_{2g}^4 e_g^2$) is electronically triply degenerate with spin multiplicity of 5 i.e., ${}^5T_{2g}$ and the ground state for low spin ($t_{2g}^6 e_g^0$) is singly degenerate with spin multiplicity of i.e., ${}^1A_{1g}$.

As the ligand field strength (Δ_o) increases ${}^1A_{1g}$ excited state of high spin complex falls rapidly and a position is reached at which ${}^1A_{1g}$ becomes ground state. At this position the pairing of electrons takes place i.e., at this position the HS complex just starts to change in LS complex resulting in a discontinuity in the T-S diagram. Therefore, this point is called high spin- low spin cross over point. This cross over point is observed at $\frac{\Delta_o}{B'} = 20$ and is represented by a vertical line. To the left of this line we have high spin complex and to the right we have low spin complex.

For low spin complexes, the ground state $^1A_{1g}$ is taken as the abscissa, therefore, the right hand part of the T-S diagram is redrawn.

The electronic spectrum of high spin d^6 -octahedral complex shows only one electronic transition $E_g \leftarrow ^5T_{2g}$ and it gives the direct measure of Δ_o . For example, $[\text{CoF}_6]^{3-}$ complex ion is blue coloured and only one electronic transition $^5E_g \leftarrow ^5T_{2g}$ occurs at 13100 cm^{-1} . Therefore, Δ_o for the complex ion is 13100 cm^{-1} .

The electronic spectra of low spin Co^{3+} complexes show two spin allowed transitions $^1T_{1g} \leftarrow ^1A_{1g}$ and $^1T_{2g} \leftarrow ^1A_{1g}$ (shown on right of T-S diagram). There are some other spin allowed transitions but these are of higher energies. These are masked by charge transfer transitions and, therefore, are not observed.

For example, an electronic spectrum of low spin complex, $[\text{Co}(\text{en})_3]^{3+}$ shows two bands at 21500 cm^{-1} and 29500 cm^{-1} corresponding to the transitions:

$$^1T_{1g} \leftarrow ^1A_{1g}; E_1 = \nu_1 = 21500 \text{ cm}^{-1}$$

$$^1T_{2g} \leftarrow ^1A_{1g}; E_2 = \nu_2 = 29500 \text{ cm}^{-1}$$

Now

$$\frac{E_2}{E_1} = \frac{E_2/B'}{E_1/B'} = \frac{29500}{21500} = 1.37$$

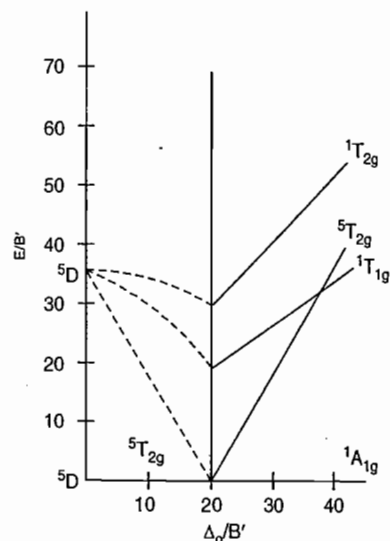

Figure 5.56 Simplified T-S diagram for Co^{3+} complex.

Now from Figure 5.56, by sliding a ruler along horizontal axis, this ratio is obtained at $\frac{\Delta_o}{B'} = 40$. If a

vertical line is drawn at this point, then $\frac{E_1}{B'} = \frac{21500}{B'} = 38$.

$$\text{Thus, } B' = \frac{21500}{38} = 565 \text{ cm}^{-1}$$

$$\text{Also, since } \frac{\Delta_o}{B'} = 40$$

$$\text{Thus, } \Delta_o = 40 \times 565 = 22600 \text{ cm}^{-1}$$

Tanabe-Sugano Diagram for d^4 -octahedral Complexes

T-S diagram for d^4 -octahedral complexes is shown in Figure 5.57.

The free ion ground state term for d^4 -configuration is 5D and there are various excited states out of which 3H is important. In octahedral complexes 5D term splits into 5E_g (lower energy) and $^5T_{2g}$ (higher energy) and 3H state splits into two $^3T_{1g}$, 3E_g and $^3T_{2g}$ states out of which $^3T_{1g}$ state of lower energy is important. It is once again to be noted that ground state of high spin complex ($t_{2g}^3 e_g^1$) is doubly degenerate with spin multiplicity of 5 i.e., 5E_g and the ground state for low spin complex ($t_{2g}^4 e_g^0$) is triply degenerate with spin multiplicity of 3, i.e., $^3T_{1g}$.

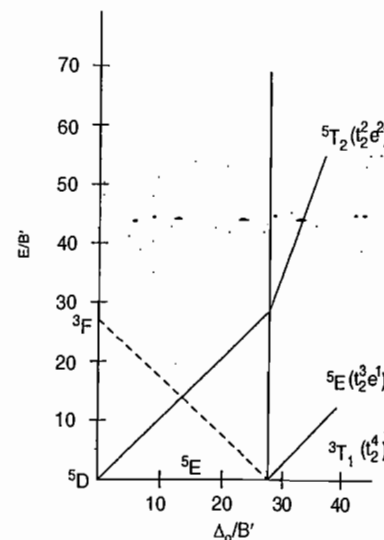

Figure 5.57 T-S diagram for d^4 complexes.

As the ligand field strength increases, the ${}^3T_{1g}$ (derived from 3H state) excited state of high spin complex falls rapidly and a position is obtained where pairing of electrons takes place and now the ground state becomes ${}^3T_{1g}$. This point observed at $\frac{\Delta_o}{B'} = 27$ is indicated by a vertical line. To the left of this point we have high spin complex and to the right we have low spin complex. The singlet states and higher triplet states are omitted from the simplified diagram. They have no relevance to the observed spectra of complexes. In low spin complexes ${}^3T_{2g} \leftarrow {}^3T_{1g}$ and ${}^3T_{2g} \leftarrow {}^3T_{1g}$ transitions are observed.

T-S Diagram for d^7 -Octahedral Complexes

T-S diagram for d^7 -octahedral complexes is shown in Figure 5.58.

The free ion ground state for d^7 -configuration is 4F and one excited state of same multiplicity is and one of the other excited states is 2G which is important. In octahedral field 4F term splits into ${}^4T_{1g}$, ${}^4T_{2g}$ and ${}^4A_{2g}$ terms. 4P term does not split but transforms into ${}^4T_{1g}(P)$ term. ${}^4T_{1g}$ is the ground state. 2G term splits into four different states out of which 2E_g is important. For high spin complexes the ground state term is ${}^4T_{1g}(t_{2g}^5 e_g^2)$ and for low spin complex the ground state term is ${}^2E_g(t_{2g}^6 e_g^1)$.

In the d^7 -T-S diagram the 2E_g state derived from 2G decreases in energy rapidly as ligand field strength increases and a position is reached where pairing of electrons occurs. This position is obtained at $\Delta_o / B' = 22$. At this point HS and LS complexes remain in equilibrium.

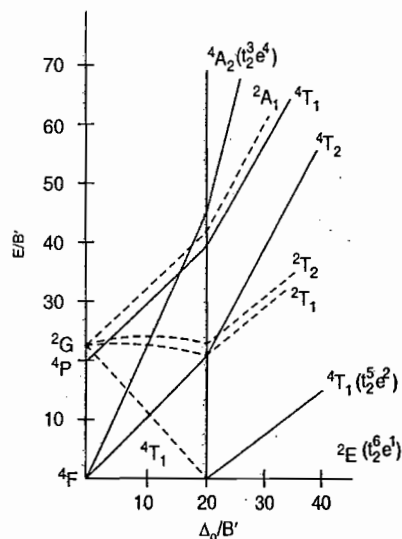

Figure 5.58. T-S diagram for d^7 -octahedral complexes.

To the right side of the vertical line of the Figure 5.58 the complex becomes a low spin and the ground state becomes 2E_g . Now the 2E_g state is taken on horizontal line. After spin cross over point, with increase in ligand field strength, the energy of ${}^4T_{1g}$ increases as an excited state.

The spin allowed transitions for d^7 -low spin complexes are :

$$\left. \begin{array}{l} {}^2T_{1g} \leftarrow {}^2E_g \\ {}^2T_{2g} \leftarrow {}^2E_g \end{array} \right\} \text{nearly the same energy}$$

and ${}^2A_{1g} \leftarrow {}^2E_g$ (at much higher energy to be observed)

The electronic spectrum of $[\text{CoF}_6]^{4-}$ shows three electronic transitions.

$${}^4T_{2g} \leftarrow {}^4T_{1g} \quad ; \quad E_1 = \nu_1 = 7150 \text{ cm}^{-1}$$

$${}^4T_{2g} \leftarrow {}^4T_{1g} \quad ; \quad E_2 = \nu_2 = 15200 \text{ cm}^{-1}$$

$${}^4T_{1g}(P) \leftarrow {}^4T_{1g}(F) \quad ; \quad E_3 = \nu_3 = 19200 \text{ cm}^{-1}$$

The ratio
$$\frac{E_2}{E_1} = \frac{E_2/B'}{E_1/B'} = \frac{15200}{7150} = 2.12$$

This ratio is obtained at $\frac{\Delta_o}{B'} = 9.4$

If we draw a vertical line at $\frac{\Delta_o}{B'} = 9.4$, then $\frac{E_1}{B'} = 9$

Therefore,
$$B' = \frac{7150}{9} = 795 \text{ cm}^{-1}$$

$$\begin{aligned} \frac{\Delta_o}{B'} &= 9.4 \\ \therefore \Delta_o &= B' \times 9.4 \\ &= 795 \times 9.4 \\ &= 7475 \text{ cm}^{-1} \end{aligned}$$

For low spin complexes of Co^{3+} ion like $[\text{Co}(\text{NH}_3)_6]^{3+}$, $[\text{Co}(\text{en})_3]^{3+}$, $[\text{Co}(\text{ox})_3]^{3-}$ the ground state corresponding to the $t_{2g}^6 e_g^1$ configuration is represented as :

$$d_{xy}^2 d_{yz}^2 d_{zx}^2$$

when one of the electrons from t_{2g}^6 is excited to e_g orbital the electronic configuration becomes $t_{2g}^5 e_g^1$. There are two singlet states ${}^1T_{1g}$ and ${}^1T_{2g}$ corresponding to $t_{2g}^5 e_g^1$ configuration.

${}^1T_{1g}$ state can be represented by any of the three ways :

$$d_{xy}^1 d_{yz}^2 d_{zx}^2 d_{x^2-y^2}^1$$

$$d_{xy}^2 d_{yz}^1 d_{zx}^2 d_{z^2}^1$$

$$d_{xy}^2 d_{yz}^2 d_{zx}^1 d_{z^2}^1$$

$^1T_{2g}$ state can be represented by any of the three ways :

$$d_{xy}^1 d_{yz}^2 d_{zx}^2 d_z^1$$

$$d_{xy}^2 d_{yz}^1 d_{zx}^2 d_x^1$$

$$d_{xy}^2 d_{yz}^2 d_{zx}^1 d_x^1$$

The energy of $^1T_{1g}$ state is lower because in this state the t_{2g} hole is as close as possible to e_g electron. In general, the following spin allowed transitions are possible :

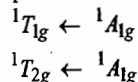

Transitions to higher singlet states 1E_g and $^1A_{2g}$ corresponding to $t_{2g}^4 e_g^2$ and $t_{2g}^3 e_g^3$ configurations are of extremely high energy and are usually not observed.

The colours of *cis* and *trans*-isomers of complexes $[\text{CoL}_4\text{X}_2]$ or $[\text{Co}(\text{L}-\text{L})_2\text{X}_2]$ frequently differ. Because (like a tetrahedral complex) a *cis* isomer lacks a centre of symmetry, its bands in spectrum are more intense than those of centrosymmetric *trans*-isomer. For example, the *cis*-isomer of $[\text{Co}(\text{en})_2\text{Cl}_2]^+$ is violet whereas the *trans*-isomer is bright green.

In $[\text{CoL}_4\text{X}_2]^+$ or $[\text{Co}(\text{L}-\text{L})_2\text{X}_2]^+$ complex the symmetry is lowered and the $^1T_{1g}$ and $^1T_{2g}$ states are split. The *trans* isomer will split the excited states more than the *cis*-isomer. Splitting of lowest excited state ($^1T_{1g}$) is more appreciable than the other excited states. If the two different ligands (e.g., $\text{L}-\text{L} = \text{en}$ and $\text{X} = \text{F}$) differ appreciably in field strength, the ν_1 bands split completely giving rise to three separate bands for the *trans*-isomer whereas the *cis*-isomer commonly show no distinct splitting and show slight asymmetry in the lower energy band.

When the two weak ligands are *trans* to one another on z -axis, they interact with only d_{z^2} -orbital and the effective field strength along z -axis is the average of the field strengths of the two ligands. In the *cis*-isomer the weak ligands are *cis* to one another in xy -plane and two of the four strong ligands are *trans* to one another along the z -axis. The splitting of $^1T_{1g}$ state depends on the differences between the strength of ligands on z -axis and in xy -plane and thus the splitting of *trans* complex is twice of the *cis* complex.

T-S Diagram for d^5 -octahedral Complexes

T-S diagram for d^5 -octahedral complexes is shown in Figure 5.59.

The free ion ground state term for d^5 -configuration is 6S and there are various excited states of different spin multiplicities out of which only 2I is important. In octahedral field 6S term does not split but transforms into $^6A_{1g}$ but 2I term splits into five excited states out of which only $^2T_{2g}$ is important.

Ground state term for high spin complex is $^6A_{1g} (t_{2g}^3 e_g^2)$ and ground state term of low spin complex is $^2T_{2g} (t_{2g}^5 e_g^0)$.

As the ligand field strength increases, the energy of $^2T_{2g}$ (derived from 2I) falls rapidly and a position is reached where $^2T_{2g}$ state becomes ground state. At this point $\Delta_o / B' = 28$ and pairing of electrons occurs and to right side of the diagram complex becomes low spin.

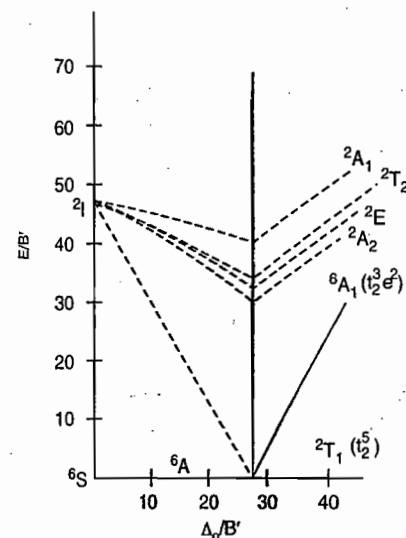

Figure 5.59. T-S diagram for d^5 octahedral complexes.

After spin cross over point with increase in ligand field strength the energy of $^6A_{1g}$ increases as an excited state.

Calculation of Δ from Spectra

- For d^1 , d^4 , d^6 and d^9 octahedral and tetrahedral complexes, there is only one electronic transition and it has energy equal to Δ_o or Δ_T .
- For d^2 , d^3 , d^7 and d^8 high spin octahedral and tetrahedral complexes three transitions are possible. The magnitude of Δ is equal to the energy of the lowest transition of the three which are observable for d^2 and d^7 configuration. Δ for d^2 and d^7 configuration is the difference in energy between the first and third transitions. In other words, Δ is the energy difference between adjacent A_{2g} and T_{2g} terms.

Fill in the Blanks

- A compound absorbs the radiation of red colour. The colour of the compound is
- The broad and unsymmetrical band in the absorption spectrum of $[\text{Ti}(\text{H}_2\text{O})_6]^{3+}$ is mainly due to
- The intensity of colour of $[\text{CoCl}_4]^{2-}$ is than that of $[\text{Co}(\text{H}_2\text{O})_6]^{2+}$.
- The intense red colour of deoxyhemoglobin is due to $M \rightarrow L \text{ CT}$
- The electron transfer in LMCT is Laporte and spin
- $\text{Cu}(\text{II})$ forms a faint pink coloured complex with *o*-phenanthroline. When this complex is reduced, the colour of this compound disappears. The colour of this compound is due to
- The complex $[\text{Co}(\text{H}_2\text{O})_6]^{2+}$ is and and
- Number of microstates for V^{3+} (d^2 -configuration) is
- Lowest energy state for $[\text{V}(\text{NH}_3)_6]^{3+}$ is
- Lowest energy state for $[\text{Cr}(\text{CN})_6]^{3-}$ is
- The blue colour of $[\text{CoCl}_4]^{2-}$ is due to and transitions.
- The complex $[\text{TiCl}_6]^{3-}$ absorbs at 13000 cm^{-1} . The value of Δ_o is
- The intense colour of $\text{KFe}[\text{Cr}(\text{CN})_6]$ is due to
- The complimentary colour of orange is
- Ground state for $[\text{Cr}(\text{CN})_6]^{3-}$ is electronically
- The lowest energy electronic transition for $[\text{Ni}(\text{NH}_3)_6]^{2+}$ is
- The intense blue colour of $[\text{Re}_2\text{Cl}_8]^{2-}$ is due to
- Ground state term for Ni^{2+} ion is
- The complex $[\text{FeCl}_4]^{2-}$ is colourless because it
- The complex $[\text{Co}(\text{NH}_3)_6]^{3+}$ has λ_{max} value than $[\text{Co}(\text{CN})_6]^{3-}$.

- [Ans. 1. green 2. Jahn-Teller distortion
3. greater 4. MLCT
5. allowed, allowed 6. $d-d$ transition
7. high spin, paramagnetic, coloured 8. 45
9. $^3T_{1g}$ 10. $^4A_{2g}$
11. some $p-d$ mixing, spin allowed
12. 13000 cm^{-1}
13. inter valence charge transfer, i.e., Fe^{2+} to Cr^{3+}
14. blue 15. non-degenerate

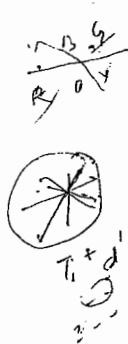

- $^3A_{2g} \rightarrow ^3T_{2g}$
- 3F
- higher]
- $\delta \rightarrow \delta^*$ transition
- absorbs in IR region

Objective Questions

- For which one of the following ions, the colour is NOT due to a $d-d$ transition ?
(a) CrO_4^{2-} ✓ (b) $\text{Cu}(\text{NH}_3)_4^{2+}$
(c) $[\text{Ti}(\text{H}_2\text{O})_6]^{3+}$ (d) CoF_6^{3-}
- Which one of the following complex ions shows the minimum intensity of absorption in the UV-visible region?
(a) $[\text{Cr}(\text{H}_2\text{O})_6]^{2+}$ (b) $[\text{V}(\text{H}_2\text{O})_6]^{2+}$
(c) $[\text{Mn}(\text{H}_2\text{O})_6]^{2+}$ ✓ (d) $[\text{Co}(\text{H}_2\text{O})_6]^{2+}$
- The ground state of V^{3+} ion is:
(a) 3F_2 ✓ (b) 5D_0
(c) 3F_4 (d) $^2D_{5/2}$
- The complex which exhibits lowest energy electronic absorption band is :
(a) $[\text{NiCl}_4]^{2-}$ ✓ (b) $[\text{Ni}(\text{H}_2\text{O})_6]^{2+}$
(c) $[\text{Ni}(\text{CN})_4]^{2-}$ (d) $\text{Ni}(\text{CO})_4$
- The orange colour of $\text{Cr}_2\text{O}_7^{2-}$ is due to :
(a) metal to ligand charge transfer transition
(b) ligand to metal charge transfer transition
(c) crystal-field transition
(d) charge-transfer complex formation
- The dark purple colour of KMnO_4 is due to :
(a) $d-d$ transition (b) ligand field transition
(c) charge transfer transition ✓ (d) $\sigma - \pi^*$ transition
- The absorption of $[\text{Co}(\text{NH}_3)_6]^{2+}$ is :
(a) stronger than that of $[\text{Co}(\text{NH}_3)_5\text{Cl}]^{2+}$
(b) stronger than that of $[\text{MnCl}_4]^{2-}$ ✓
(c) weaker than that of $[\text{MnCl}_4]^{2-}$ but stronger than that of $[\text{Co}(\text{NH}_3)_5\text{Cl}]^{2+}$
(d) weaker than those of both $[\text{MnCl}_4]^{2-}$ and $[\text{Co}(\text{NH}_3)_5\text{Cl}]^{2+}$

To see

8. The ground state term symbols for high spin $d^5 S^1$ and d^5 -configuration, respectively, are :
 (a) $^3 S$ and $^6 S$ (b) $^6 P$ and $^3 S$
 (c) $^7 S$ and $^6 S$ (d) $^7 P$ and $^6 S$
9. The number of absorption bands observed for $[\text{FeF}_6]^{3-}$ and $[\text{CoF}_6]^{3-}$, respectively, are :
 (a) 1 and 3 (b) 0 and 1
 (c) 0 and 3 (d) 3 and 1
10. The number of possible $d-d$ transitions in $[\text{Cu}(\text{NH}_3)_6]^{2+}$ will be :
 (a) one (b) two
 (c) three (d) four
11. The compound which shows $L \leftarrow M$ charge transfer is :
 (a) $\text{Ni}(\text{CO})_4$ (b) $\text{K}_2\text{Cr}_2\text{O}_7$
 (c) HgO (d) $[\text{Ni}(\text{H}_2\text{O})_6]^{2+}$
12. The spectroscopic ground state symbol and the total number of electronic transitions of $[\text{Ti}(\text{H}_2\text{O})_6]^{2+}$ are :
 (a) $^3 T_{1g}$ and 2 (b) $^3 A_{2g}$ and 3
 (c) $^3 T_{1g}$ and 3 (d) $^3 A_{2g}$ and 2
13. Which of the following octahedral complexes shows $^3 T_{2g} \leftarrow ^3 A_{2g}$ transition as the lowest energy visible band in its electronic spectrum ?
 (a) $[\text{Cr}(\text{NH}_3)_6]^{3+}$ (b) $[\text{FeF}_6]^{3-}$
 (c) $[\text{Co}(\text{NH}_3)_6]^{3+}$ (d) $[\text{Ni}(\text{H}_2\text{O})_6]^{2+}$
14. Ruby has a low concentration of a trivalent $3d$ -metal ion substituted for Al^{3+} in alumina giving initial excitations of the spin-allowed processes $^4 T_{2g} \leftarrow ^4 A_{2g}$ and $^4 T_{1g} \leftarrow ^4 A_{2g}$. The $3d$ -metal ion is :
 (a) $\text{Cr}(\text{III})$ (b) $\text{Fe}(\text{III})$
 (c) $\text{Co}(\text{III})$ (d) $\text{Ni}(\text{III})$
15. The compound that absorbs light of longest wavelength is :
 (a) $[\text{Cr}(\text{NO}_2)_6]^{3-}$ (b) $[\text{Cr}(\text{NH}_3)_6]^{3+}$
 (c) $[\text{Cr}(\text{H}_2\text{O})_6]^{3+}$ (d) $[\text{CrF}_6]^{3-}$
16. Which of the following compound, shows inter valence charge transfer transition ?
 (a) Pb_3O_4 (b) $\text{K}_2\text{Cr}_2\text{O}_7$
 (c) $\text{KFe}[\text{Fe}(\text{CN})_6]$ (d) $\text{Mn}_2(\text{CO})_{10}$
17. The ground state term symbol of Ni^{2+} ion is:
 (a) $^3 F$ (b) $^3 A$
 (c) $^3 P$ (d) $^3 E$

18. The bright yellow colour of $[\text{Cu}(\text{phen})_2]^+$ (phen = 1,10-phenanthroline) is due to :
 (a) $d-d$ transitions
 (b) metal to ligand charge transfer
 (c) ligand to metal charge transfer
 (d) π to π^* transition in the phenanthroline ligand
19. The pale colour of $\text{Mn}(\text{H}_2\text{O})_6^{2+}$ is due to :
 (a) spin forbidden $d-d$ transition (b) metal to ligand charge transfer
 (c) ligand to metal charge transfer (d) intra ligand excitation
20. The number of $d-d$ electronic bands in spectra for the high-spin $\text{Fe}(\text{III})$ octahedral system is:
 (a) zero (b) two
 (c) three (d) one
21. The ground state term for $t_{2g}^6 e_g^2$ in octahedral field is :
 (a) $^3 A_{2g}$ (b) $^3 E_g$
 (c) $^4 T_{1g}$ (d) $^2 A_{1g}$
22. Which one of the following electronic configuration of an octahedral metal complex will show three spin allowed electronic transitions?
 (a) $t_{2g}^1 e_g^1$ (b) t_{2g}^3
 (c) $t_{2g}^3 e_g^2$ (d) $t_{2g}^6 e_g^3$
23. The origin of the yellow colour of an aqueous solution of K_2CrO_4 is due to :
 (a) $d-d$ transition (b) H_2O to Cr^{6+} charge transfer
 (c) O^{2-} to K^+ charge transfer (d) O^{2-} to Cr^{+6} charge transfer
24. The molar absorptivity at λ_{max} is minimum for :
 (a) $[\text{Mn}(\text{H}_2\text{O})_6]^{2+}$ (b) $[\text{Cr}(\text{H}_2\text{O})_6]^{2+}$
 (c) $[\text{Co}(\text{H}_2\text{O})_6]^{2+}$ (d) $[\text{Fe}(\text{H}_2\text{O})_6]^{2+}$
25. Only one absorption band is observed in visible region of spectrum of :
 (a) $[\text{Ni}(\text{H}_2\text{O})_6]^{2+}$ (b) $[\text{Ti}(\text{H}_2\text{O})_6]^{3+}$
 (c) $[\text{Fe}(\text{CN})_6]^{4-}$ (d) VO_4^{3-}
26. The lowest energy $d-d$ transition in the $\text{Cr}(\text{III})$ complexes varies in the order :
 (a) $\text{CrCl}_6^{3-} < \text{Cr}(\text{H}_2\text{O})_6^{3+} < \text{Cr}(\text{en})_3^{3+} < \text{Cr}(\text{CN})_6^{3-}$
 (b) $\text{CrCl}_6^{3-} < \text{Cr}(\text{en})_3^{3+} < \text{Cr}(\text{H}_2\text{O})_6^{3+} < \text{Cr}(\text{CN})_6^{3-}$
 (c) $\text{Cr}(\text{CN})_6^{3-} < \text{CrCl}_6^{3-} < \text{Cr}(\text{H}_2\text{O})_6^{3+} < \text{Cr}(\text{en})_3^{3+}$
 (d) $\text{Cr}(\text{H}_2\text{O})_6^{3+} < \text{Cr}(\text{en})_3^{3+} < \text{CrCl}_6^{3-} < \text{Cr}(\text{CN})_6^{3-}$

27. The term symbol for the ground state of rhodium (Rh, atomic number 45) is 4F . The electronic configuration for this term symbol is :
 (a) $[Kr] 4d^7 5s^2$ (b) $[Kr] 4d^8 5s^1$
 (c) $[Kr] 4d^9 5s^0$ (d) $[Kr] 4d^7 5s^1 5p^1$
28. The red colour of oxyhemoglobin is mainly due to the :
 (a) $d-d$ transition
 (b) metal to ligand charge transfer transition
 (c) ligand to metal charge transfer transition
 (d) intra ligand $\pi-\pi^*$ transition
29. The crystal field stabilization energy (CFSE) value for $[Ti(H_2O)_6]^{3+}$ that has an absorption maximum at 492 nm is :
 (a) $20,325 \text{ cm}^{-1}$ (b) $12,195 \text{ cm}^{-1}$
 (c) $10,162 \text{ cm}^{-1}$ (d) $8,130 \text{ cm}^{-1}$
30. In the iso-electronic series VO_4^{3-} , CrO_4^{2-} and MnO_4^- , all members have intense charge transfer (CT) transitions. The incorrect statement is :
 (a) CT transitions are attributed to excitations of electrons from ligand (σ) to metal (e)
 (b) MnO_4^- exhibits charge transfer at shortest wavelength among the three
 (c) The wavelengths of transitions increase in the order $VO_4^{3-} < CrO_4^{2-} < MnO_4^-$
 (d) The charge on metal nucleus increases in the order $VO_4^{3-} < CrO_4^{2-} < MnO_4^-$
31. The increasing order of wavelength of absorption for the complex ions :
 (i) $[Cr(NH_3)_6]^{3+}$ (ii) $[CrCl_6]^{3-}$ (iii) $[Cr(OH_2)_6]^{3+}$ (iv) $[Cr(CN)_6]^{3-}$, is :
 (a) $iv < ii < i < iii$ (b) $iv < iii < ii < i$
 (c) $iv < i < iii < ii$ (d) $ii < iii < i < iv$
32. The correct order of LMCT energies is :
 (a) $MnO_4^- < CrO_4^{2-} < VO_4^{3-}$ (b) $MnO_4^- > CrO_4^{2-} > VO_4^{3-}$
 (c) $MnO_4^- > CrO_4^{2-} < VO_4^{3-}$ (d) $MnO_4^- < CrO_4^{2-} > VO_4^{3-}$
33. The ground states of high-spin octahedral and tetrahedral $Co(II)$ complexes are respectively :
 (a) $^4T_{2g}$ and 4A_2 (b) $^4T_{1g}$ and 4A_2
 (c) $^3T_{1g}$ and 4A_2 (d) $^4T_{1g}$ and 3A_g
34. The complex that absorbs light of shortest wavelength is :
 (a) $[CoF_6]^{3-}$
 (b) $[Co(H_2O)_6]^{3+}$
 (c) $[Co(NH_3)_6]^{3+}$
 (d) $[Co(OX)_3]^{3-}$ (OX = $C_2O_4^{2-}$)

35. The electronic spectrum of $[CrF_6]^{3-}$ shows three bands at $14,900 \text{ cm}^{-1}$, $22,400 \text{ cm}^{-1}$ and $34,800 \text{ cm}^{-1}$. The value of Δ_o in this case is :
 (a) $5,500 \text{ cm}^{-1}$ (b) $14,900 \text{ cm}^{-1}$
 (c) $22,400 \text{ cm}^{-1}$ (d) $34,800 \text{ cm}^{-1}$
36. The number of spin allowed ligand field transitions for octahedral $Ni(II)$ complexes with $^3A_{2g}$ ground state is :
 (a) two (b) three
 (c) one (d) four
37. The number of microstates for d^5 -electron configuration is :
 (a) 21×6^3 (b) 14×6^3
 (c) 7×6^2 (d) 28×6^3
38. The first excited state configuration for low spin octahedral d^4 system is :
 (a) 2E (b) 3T_2
 (c) 5E (d) 5T_2
39. MnO_4^- ion absorbs at 22000 cm^{-1} and 35000 cm^{-1} in its, UV-visible absorption spectrum. The value of Δ_t is :
 (a) 22000 cm^{-1} (b) 35000 cm^{-1}
 (c) 13000 cm^{-1} (d) 65000 cm^{-1}
40. Addition of an aqueous solution of $Fe(II)$ to potassium hexacyanochromate(III) produces a brick-red colored complex, which turns dark green at 100°C . The dark green complex is :
 (a) $Fe_4[Cr(CN)_6]_3$ (b) $KFe[Cr(CN)_6]$
 (c) $KCr[Fe(CN)_6]$ (d) $Fe[Cr(CN)_6]$
41. The ground state term $[Ni(H_2O)_6]^{2+}$ is :
 (a) $^3T_{1g}$ (b) $^3T_{2g}$
 (c) $^3A_{2g}$ (d) $^4T_{1g}$
42. An ion M^{2+} forms the complexes $[M(H_2O)_6]^{2+}$, $[M(en)_3]^{2+}$ and $[MBr_6]^{2-}$, match the complex with appropriate colour :
 (a) green, blue and red (b) blue, red and green
 (c) green, red and blue (d) red, blue and green
43. Intense blue colour of Prussian blue is a result of :
 (a) electron transfer between $Fe(II)$ and $Fe(I)$
 (b) electron transfer between $Fe(II)$ and $Fe(III)$
 (c) $d-d$ transition
 (d) paramagnetic nature of $Fe(II)$ and $Fe(III)$

44. Three bands in the electronic spectrum of $[\text{Cr}(\text{NH}_3)_6]^{3+}$ are due to the following transitions :

- (A) ${}^4T_{1g} \leftarrow {}^4A_{2g}$ (B) ${}^4T_{2g} \leftarrow {}^4A_{2g}$ (C) ${}^2E_g \leftarrow {}^4A_{2g}$

Identify the correct statement about them.

- (a) Intensity of (A) is lowest
 (b) Intensity of (C) is lowest
 (c) Intensities of (A), (B) and (C) are similar
 (d) Intensities of (B) and (C) are similar



45. One of the excited states of Ti has the electronic configuration $[\text{Ar}] 4s^2 3d^1 4p^1$. The number of microstates with zero total spin (S) for this configuration is :

- (a) 9 (b) 15
 (c) 27 (d) 60

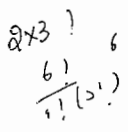

46. The electronic transition responsible for the colour of the transition metal ions is :

- (a) $d\pi \rightarrow d\pi$ (b) $d\pi \rightarrow d\sigma^*$
 (c) $d\pi \rightarrow d\pi^*$ (d) $d\pi \rightarrow d\sigma^*$

47. Intense band at 15000 cm^{-1} in the UV-visible spectrum of $[\text{Bu}_4\text{N}]_2[\text{Re}_2\text{Cl}_8]$ is due to the transition :

- (a) $\pi - \pi^*$ (b) $\delta - \delta^*$
 (c) $\delta - \pi^*$ (d) $\pi - \delta^*$

48. Silica gel contains $[\text{CoCl}_4]^{2-}$ as an indicator when activated, silica gel becomes dark blue while upon absorption of moisture, its colour changes to pale pink. This is because :

- (a) Co(II) changes its coordination number from tetrahedral to octahedral
 (b) Co(II) changes its oxidation state to Co(III)
 (c) Tetrahedral crystal field splitting is not equal to octahedral crystal field splitting
 (d) Co(II) forms kinetically labile while Co(III) forms kinetically inert complexes

49. The light pink colour of $[\text{Co}(\text{H}_2\text{O})_6]^{2+}$ and the deep blue colour of $[\text{CoCl}_4]^{2-}$ are due to :

- (a) MLCT transition in the first and $d-d$ transitions in the second
 (b) LMCT transition in both
 (c) $d-d$ transitions in both
 (d) $d-d$ transition in first and MLCT in the second

ANSWERS

- | | | | | | | |
|---------|---------|---------|---------|---------|---------|---------|
| 1. (a) | 2. (c) | 3. (a) | 4. (a) | 5. (b) | 6. (c) | 7. (b) |
| 8. (c) | 9. (b) | 10. (a) | 11. (a) | 12. (c) | 13. (d) | 14. (a) |
| 15. (d) | 16. (c) | 17. (a) | 18. (b) | 19. (a) | 20. (a) | 21. (a) |
| 22. (b) | 23. (d) | 24. (a) | 25. (b) | 26. (a) | 27. (a) | 28. (b) |
| 29. (d) | 30. (b) | 31. (c) | 32. (a) | 33. (b) | 34. (c) | 35. (b) |
| 36. (b) | 37. (c) | 38. (c) | 39. (c) | 40. (c) | 41. (c) | 42. (c) |
| 43. (b) | 44. (b) | 45. (b) | 46. (b) | 47. (b) | 48. (a) | 49. (c) |

Subjective Questions

- The colour of $\text{trans} [\text{Co}(\text{en})_2\text{F}_2]^+$ is less intense than that of $\text{cis} [\text{Co}(\text{en})_2\text{F}_2]^+$.
- Colour of $\text{trans} [\text{Co}(\text{en})_2\text{F}_2]^+$ is less intense than that of $\text{trans} [\text{Co}(\text{en})_2\text{Cl}_2]^+$.
- The three absorption bands for $[\text{CrF}_6]^{3-}$ are observed in an electronic spectrum at 14900 cm^{-1} , 22700 cm^{-1} and 34400 cm^{-1} . Determine the values of B' and Δ_o .
- The complex $[\text{Co}(\text{NH}_3)_6]^{3+}$ is yellow-orange whereas $[\text{Co}(\text{H}_2\text{O})_6]^{3+}$ is blue. Explain.
- Aqueous solution of $\text{Ni}(\text{NO}_3)_2$ is green. Addition of aqueous NH_3 causes the colour change to blue. If ethylenediamine is added to the green solution, the colour changes to violet. Explain.
- What are forbidden and allowed transitions? Explain giving examples.
- In general, UV-visible absorption bands of transition metal complexes are unsymmetric and broad whereas those of lanthanoid ions (Ln^{3+}) complexes are sharp.
- CN^- is a strong ligand. Do you expect $\text{K}_4[\text{Fe}(\text{CN})_6]$ to be intensely coloured?
- CdCO_3 is colourless whereas CdS is yellow.
- Cu^{2+} ions are coloured and paramagnetic while Zn^{2+} ion are colourless and diamagnetic.
- Characterize the origin of electronic transitions in the following and indicate the intensity of the complexes : $[\text{CoCl}_4]^{2-}$, $[\text{MnBr}_4]^{2-}$, $[\text{Fe}(\text{bipy})_3]^{2+}$, MnO_4^- , $[\text{Mn}(\text{H}_2\text{O})_6]^{2+}$, $\text{KFe}[\text{Fe}(\text{CN})_6]$, $\text{Fe}_4[\text{Fe}(\text{CN})_6]_3$, $\text{Cr}_2\text{O}_7^{2-}$, CdS , $\text{Ni}(\text{CO})_4$.
- Dimethyl sulphoxide (DMSO) reacts with $\text{Co}(\text{ClO}_4)_2$ in ethanol to form pink coloured compound (A) which has a magnetic moment of 4.9 B.M. However when DMSO reacts with CoCl_2 a dark blue coloured compound (B) is formed which has a magnetic moment of 4.6 B.M.
 (i) Suggest a formula and structure of compound (A) and (B).
 (ii) Rationalize the colour of these complexes.
- Iron forms $\text{K}_4[\text{Fe}(\text{CN})_6]$, $\text{K}_3[\text{Fe}(\text{CN})_6]$, $\text{Fe}[\text{Fe}(\text{CN})_6]$, $\text{Fe}_2[\text{Fe}(\text{CN})_6]$ and $\text{KFe}[\text{Fe}(\text{CN})_6]$ complexes. $\text{KFe}[\text{Fe}(\text{CN})_6]$ is more intensely coloured than the other complexes. Explain.
- The absorption spectrum of $[\text{Ti}(\text{H}_2\text{O})_6]^{3+}$ shows one band as broad and unsymmetrical. Explain.
- Solutions of the complexes $[\text{CoL}_6]^{3+}$ and $[\text{CoL}'_6]^{3+}$ where L and L' are two different neutral monodentate ligands, are pink and yellow respectively. Which would be expected to have the higher value of Δ_o ?
- Aqueous solution of Cr(III) is violet in colour whereas aqueous solution of Y(III) and La(III) which belong to same group are colourless. Explain.
- Oxyhemoglobin is bright red whereas deoxyhemoglobin is purple. Explain.
- A concentrated aqueous solution of CuCl_2 is bright green whereas, when this solution is diluted, the solution becomes light blue. Explain.
- High spin octahedral complexes of Mn^{2+} ion are colourless. Explain.
- Aqueous solution of Ni(II) is green coloured whereas that of Zn(II) is colourless. Explain.

Handwritten notes: Ti^{3+} and $(\text{H}_2\text{O})_6^{3+}$

- 21. The $[\text{Cr}(\text{H}_2\text{O})_6]^{3+}$ ion is violet in colour whereas $[\text{Cr}(\text{CN})_6]^{3-}$ is yellow. Explain.
- 22. The single absorption bands for $[\text{Ti}(\text{H}_2\text{O})_6]^{3+}$ and $[\text{Ti}(\text{NCS})_6]$ occur in their absorption spectra at 470 nm and 544 nm respectively. (i) Calculate the crystal field splitting energies for these complex ions in kJ mol^{-1} . (ii) Predict the colours of these complex ions.
- 23. The complex $[\text{Co}(\text{H}_2\text{O})_6]^{2+}$ is light pink whereas $[\text{CoCl}_4]^{2-}$ is blue. Explain.
- 24. Colour of $\text{CuSO}_4 \cdot 5\text{H}_2\text{O}$ is blue. Explain.

Orbital paramagnetism is temp independent
Spin paramagnetism is temp dependent

paramagnetism \rightarrow from spin + orbital motion
Curie's Constant $(C) = \frac{N\mu_{\text{eff}}^2}{R}$

Magnetite $(\text{Fe}_3\text{O}_4) \rightarrow$ ferrimagnetic
MnO - antiferromagnetic

Fe, Co, Ni, CrO_2 - ferromagnetic

Normally $g = 5(5+1) + 5(2+1) - 2(4+1)$

or $g = \frac{3}{2} + \frac{2\lambda}{\Delta}$

$\mu_{\text{spin}} = 2.828B$
 $\mu = g\sqrt{S(S+1)}$

Orbital paramagnetism is temp independent

Paramagnetism $\propto \frac{1}{\text{temp}}$

6 Magnetism

Diamagnetic field \rightarrow lines opp to applied magnetic field & is repelled by MF passed in

When a substance is placed in an external (or applied) magnetic field, there is an induced circulation of the electrons in the substance. This induced circulation of electrons gives rise to a magnetic moment or magnetic field that usually opposes the applied magnetic field. As a result the substance is repelled by the magnetic field and this effect is said to be a diamagnetic effect. This effect is caused by the presence of paired electrons. The diamagnetic effect exists only when a substance is placed in a magnetic field. This effect arises in substances in which there are only paired electrons or paired electrons along with unpaired electrons. If a substance has only paired electrons, the diamagnetic effect is dominated. On the other hand, if a substance has paired as well as unpaired electrons, the paramagnetic effect is dominated.

The substances having only paired electrons exhibit a weak magnetic moment known as diamagnetism and such substances are called diamagnetic substances. In these substances, the induced circulation of electrons occurs within the orbitals of the substances that are occupied in the ground state. In some cases the molecules are paramagnetic despite having only paired electrons, the induced magnetic moment is aligned in the direction of applied magnetic field because they use LUMO that is close to HOMO in energy. This orbital paramagnetism can be distinguished from spin paramagnetism by the fact that it is temperature independent and it is called temperature independent paramagnetism because the electrons present in HOMO can be excited to LUMO by thermal motion.

Any substance that has one or more unpaired electrons exhibits stronger and permanent magnetic property is known as paramagnetism. Paramagnetism arises from the spin and orbital motion of the unpaired electrons in the absence of an external magnetic field. Such substances are said to be paramagnetic. When a paramagnetic substance is placed in an external magnetic field, the permanent magnetic moments tend to align themselves in the direction of the external magnetic field and as a result are attracted into the external magnetic field. Since the paramagnetic effect is much larger than the diamagnetic effect and opposite to the diamagnetic effect, the paramagnetic effect, therefore, cancels the diamagnetic effect. Hence paramagnetic effect is dominant in all substances containing either one or more unpaired electrons. Thus, due to net paramagnetic effect the substance is attracted into the external magnetic field.

In the absence of external magnetic field, the magnetic moments of individual molecules are randomized by thermal motion and the substance, as a result, has no magnetic moment because the randomization of individual magnetic moments causes cancellation of one another as shown in Figure 6.1.

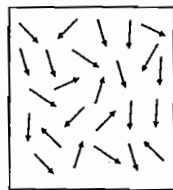

Figure 6.1 Randomization of magnetic moments of a paramagnetic sample

In the presence of external magnetic field, there is competition between randomization of individual magnetic moments due to thermal motion and field strength for alignment. Consequently, paramagnetic effect decreases in magnitude as the temperature increases. It is due to the fact that an increase in temperature increases randomization and decreases the paramagnetic effect. The paramagnetic character increases with increases in the number of unpaired electrons.

The measurement of magnetic properties experimentally does not involve the measurement of magnetic moment but instead magnetic moment is calculated from the measurement of magnetic susceptibility. When a substance is placed in an external field of strength (H), the induced magnetic field produced in the substance will either be greater than or less than the applied field depending whether substance is paramagnetic or diamagnetic. The difference between induced magnetic field (B) in the substance and applied magnetic field (H) is given by,

$$\Delta H = B - H \quad \dots(i)$$

The difference between the applied magnetic field and the induced magnetic field in substance is expressed in terms of intensity of magnetization (I) as shown below :

$$4\pi I = B - H \quad \dots(ii)$$

The intensity of magnetization is the magnetic moment per unit volume.

The induced magnetic field (B) and intensity of magnetization both are proportional to the applied magnetic field (H). Now divide the equation (ii) by H , we get,

$$\frac{4\pi I}{H} = \frac{B}{H} - 1 \quad \dots(iii)$$

The term $\frac{B}{H}$ is called the magnetic permeability and it is the ratio of density of lines of magnetic force in the sample to the density of lines of magnetic force in vacuum.

The term $\frac{I}{H}$ is the magnetic susceptibility per unit volume of the substance and is called volume magnetic susceptibility (κ). The quantity κ is measure of the extent to which a substance tends to be magnetized.

$$4\pi\kappa = \frac{B}{H} - 1 \quad \dots(iv)$$

The quantity κ is positive for paramagnetic substances and negative for diamagnetic substances. It is dimensionless quantity. The volume susceptibility is concentration dependent. Often, the magnetic susceptibility obtained experimentally is the specific (or mass) susceptibility χ (chi) and it is obtained dividing κ by the density of the sample.

$$\chi = \frac{\kappa}{d} \quad \dots(v)$$

Finally a molar susceptibility (χ_M) is obtained by multiplying χ by the molecular mass (M) of the sample.

$$\chi_M = \chi \cdot M = \frac{\kappa}{d} \cdot M \quad \dots(vi)$$

Molar magnetic susceptibility is a measure of the degree to which one mole of a substance interacts with the applied magnetic field.

The magnetic susceptibility measured for a substance consists of contributions from paramagnetic and diamagnetic susceptibilities. The paramagnetic susceptibility is much greater than that of diamagnetic substance. For a diamagnetic substance, the diamagnetic susceptibility will be the sum of contributions from its constituent atoms. For substances containing very small diamagnetism as compared to paramagnetism, then it can be neglected. If a substance contains large number of diamagnetic atoms per paramagnetic atom (as in a metal ion complex), the diamagnetic contribution will be significant and can not be neglected. It is observed that diamagnetism is an additive quantity and the diamagnetic susceptibility of a substance can be obtained as a sum of contributions from each constituent atoms. If a substance contains paired as well as unpaired electrons, the applied field induces a diamagnetism in opposition to the paramagnetism of the unpaired electrons. Thus, it reduces the susceptibility of the sample below that which is due to paramagnetism alone. The measured magnetic susceptibility should be corrected by subtracting diamagnetic susceptibility from it.

Corrected or paramagnetic susceptibility

= measured susceptibility - diamagnetic susceptibility

$$\chi_M^P = \chi_M - \chi_M^D \quad \dots(vii)$$

Since the diamagnetic susceptibility is a negative quantity, the above relationship can be written as :

$$\chi_M^P = \chi_M + |\chi_M^D| \quad \dots(viii)$$

From classical theory, the corrected molar susceptibility (χ_M^P) is related to the effective magnetic moment (μ_{eff}) of the substance according to the following equation :

$$\chi_M^P = \frac{N^2 \mu_{\text{eff}}^2}{3RT} \quad \dots(ix)$$

Where N is Avogadro number ($= 6.023 \times 10^{23}$), T is the absolute temperature, R is the ideal gas constant. μ_{eff} is expressed in Bohr magnetons (B.M.).

$$\mu_{\text{eff}} = \left(\frac{3RT \chi_M^P}{N^2} \right)^{1/2} \text{ B.M.} \quad \dots(x)$$

$$\text{or } \mu_{\text{eff}} = 2.84(\chi_M^P T)^{1/2} \text{ B.M.} \quad (\because 1 \text{ B.M.} = \frac{eh}{4\pi m}) \quad \dots(xi)$$

Pierre Curie has shown that paramagnetic susceptibility is inversely proportional to the absolute temperature.

$$\chi_M^P = \frac{C}{T} \quad \dots(xii)$$

Where C is Curie constant and is equal to $\frac{N^2 \mu_{\text{eff}}^2}{3R}$.

This expression is known as Curie's Law. This law is restatement of equation (xi).

The Curie's law is valid only for paramagnetic substances that are magnetically dilute. The paramagnetic susceptibility (corrected for diamagnetism) plotted *versus* the reciprocal of the absolute temperature (or reciprocal of paramagnetic susceptibility *versus* absolute temperature) produces a straight line with zero intercept (Figure 6.2) and slope C . In some substances that are not magnetically dilute, the magnetic moments of unpaired electrons on neighbouring atoms may couple with each other. These substances may behave as either ferromagnetic or ferrimagnetic or anti-ferromagnetic. These compounds obey the Curie-Weiss law.

$$\chi_M^P = \frac{C}{(T-\theta)} \quad \dots(\text{xiii})$$

where θ , an empirical constant, is the temperature at which the line intercepts the T axis in a plot of $1/\chi_M^P$ *versus* T . In this plot the intercept for these substances is not zero (Figure 6.2). For these compounds, the magnetic moment at a given temperature can be calculated from the equation,

$$\mu_{\text{eff}} = 2.84 [\chi_M^P (T-\theta)]^{1/2} \quad \dots(\text{xiv})$$

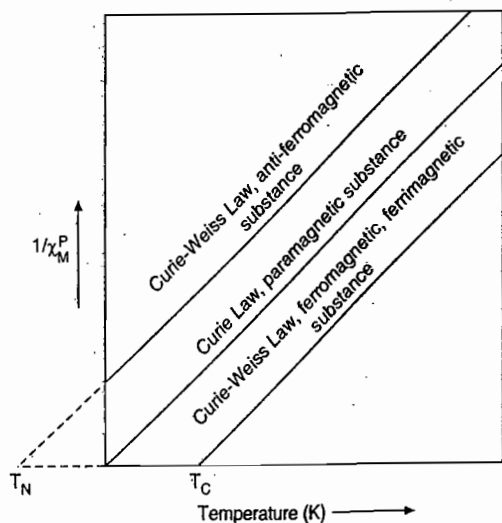

Figure 6.2. Plot of the reciprocal of paramagnetic susceptibility versus absolute temperature.

If the value of θ is positive, the substance is said to be ferromagnetic and if the value of θ is negative the substance is said to be anti-ferromagnetic.

If there is interaction between the magnetic moment on neighbouring atoms of a paramagnetic substance, spontaneous ordering (Figure 6.3) of the magnetic moment occur below a particular temperature, called as critical temperature. If alignment of all the magnetic moment of neighbouring atoms is in the same direction and produce a permanent magnetic moment, the substance is said to be ferromagnetic and the critical temperature is called the Curie temperature, T_C . Above this temperature the substance behaves as a normal paramagnetic substance. Below Curie temperature χ_M for a ferromagnetic substance is much higher than χ_M for a normal paramagnetic substance. Below T_C the

ferromagnetic substance obey Curie-Weiss law. Fe, Co, Ni and CrO_2 exhibit ferromagnetic below Curie temperatures 1043 K, 1404 K, 631 K and 386 K respectively.

If some of the magnetic moments are systematically aligned opposite to the others to give a resultant magnetic moment, the substance is said to be ferrimagnetic and the critical temperature once again is called the Curie temperature, T_C . An important example of ferrimagnetic substance is magnetite, Fe_3O_4 . In this substance, the magnetic moments of Fe(II) and Fe(III) are aligned in opposite directions and the resultant magnetic moment is only from Fe(II) moments.

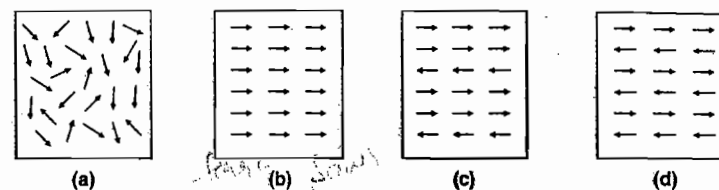
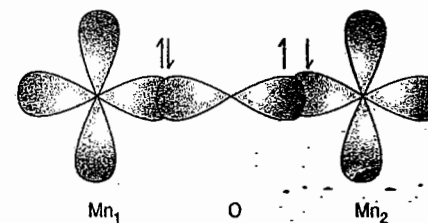

Figure 6.3 (a) Randomization of magnetic moments for paramagnetic substance. (b), (c) and (d) alignment of magnetic moments for ferromagnetic, anti-ferromagnetic and ferrimagnetic substances respectively.

If half of the magnetic moments are aligned in opposite direction to the other half resulting in a net zero magnetic moment, the substance is said to be anti-ferromagnetic and the critical temperature is called the Neel temperature. MnO is an anti-ferromagnetic substance with Neel temperature of 116 K.

In MnO , there is a σ interaction between the half-filled e_g orbitals of Mn^{2+} ions and the filled p orbitals of oxide ion as shown below :



The spins of all the five d -electrons in one Mn^{2+} are opposite to that of other Mn^{2+} ion. The oxide electron which interacts with Mn_1 must have its spin opposite to that of Mn_1 electron leaving an electron of opposite spin to interact with Mn_2 . Therefore, the manganese electrons are anti-ferromagnetically coupled. Another example of anti-ferromagnetic substance is NiO .

Variation of magnetic susceptibility with temperature for diamagnetic, paramagnetic, ferromagnetic (or ferrimagnetic) and anti-ferromagnetic substances is shown in Figure 6.4.

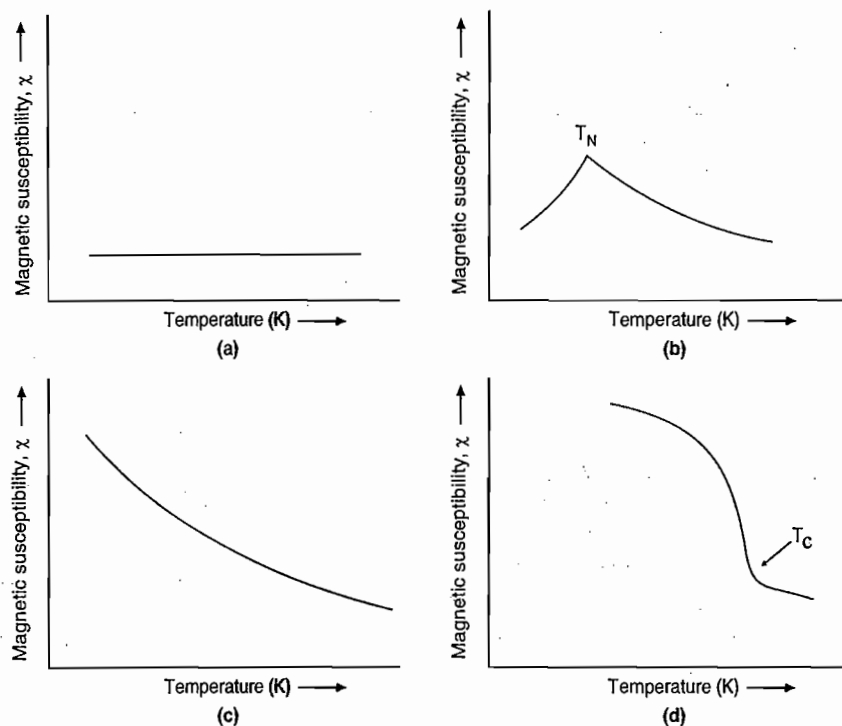

Figure 6-4 Plot of magnetic susceptibility versus T for: (a) diamagnetic, (b) anti-ferromagnetic, (c) paramagnetic, and (d) ferro-magnetic substances. T_N and T_C are Curie and Neel temperature respectively.

Magnetic Moment

When a charged particle is subjected to be in motion, a magnetic moment is produced. There are two types of electron motion (electron treating the charged particle) that give rise to magnetic moments. The first is the electron spin which is the rotation of electron about its axis. The magnetic moment resulting from this electron spin is called the spin magnetic moment (μ_s) which is characterised by the spin angular momentum quantum number, S . The second is the electron orbiting about the nucleus. The magnetic moment resulting from this electron orbiting is called the orbital magnetic moment, μ_L which is characterised by total orbital angular momentum L . Thus the magnetic moment of paramagnetic substance is due to the contribution from spins and orbital motions of unpaired electrons.

The magnetic moment of a paramagnetic substance depends upon the energy difference between adjacent states of J values J' and $(J' + 1)$. In general, J' and $(J' + 1)$ states are the ground and first excited states respectively. The energy difference between two adjacent states is given by the expression $(J' + 1)\lambda$ where λ is called the spin orbit coupling constant. Let us consider, for example, 3F state of d^2 configuration for which $2S + 1 = 3$ or $S = 1$ and $L = 3$ for F term and $J = 4, 3, 2$. Thus, 3F state splits into 3F_2 , 3F_3 and 3F_4 states. Each of these states have their definite amount of energies.

According to Hund's rule the 3F_2 state is the ground state and energies of these states increase in the order $^3F_2 < ^3F_3 < ^3F_4$. The energy difference between successive pairs of these states is 3λ and 4λ respectively. In magnetic field these states are further split into $(2J + 1)$ different states each of which is separated from adjacent state by an energy $g\mu_B H$, where g is a constant called as Lande splitting factor for the substance, H is the magnetic field and μ_B is the Bohr magneton. The splitting pattern for 3F state is shown in Figure 6.5.

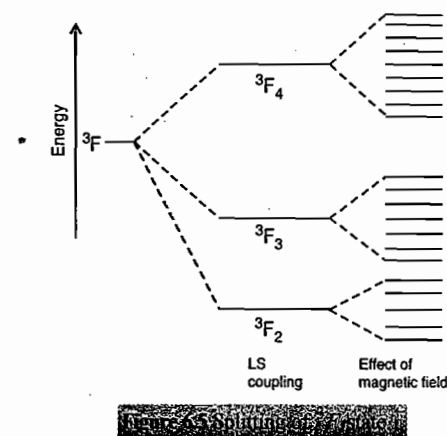

The value of λ is very small for light atoms and larger for the heavier atoms. The extent to which the states corresponding to different J values are populated at ordinary temperature depends upon how large the energy difference between ground and excited states as compare with the thermal energy available, kT .

At 300 K,

$$kT = \sim 200 \text{ cm}^{-1}$$

If the separation between ground state and first excited state is sufficiently large *i.e.*, $> kT$ then spin orbit coupling (LS coupling) will be appreciable. Such a situation arises in heavier elements, particular for lanthanoids. For such substances the magnetic moment is given by,

$$\mu = g\sqrt{J(J+1)} \quad \dots(i)$$

where J is the total angular momentum quantum number and g is the Lande splitting factor for the electron.

$$g = 1 + \frac{J(J+1) + S(S+1) - L(L+1)}{2J(J+1)}$$

$$\text{or} \quad g = \frac{3}{2} + \frac{S(S+1) - L(L+1)}{2J(J+1)}$$

$J = L + S$ for more than half-filled subshell

and $J = L - S$ for less than half-filled subshell.

For example, Pr^{3+} has the configuration $4f^2$

1	1						
+3	+2	+1	0	-1	-2	-3	

$$S = \frac{1}{2} + \frac{1}{2} = 1$$

$$L = 3 + 2 = 5$$

Since f -subshell is less than half-filled. Therefore,

$$J = L - S = 5 - 1 = 4$$

$$g = \frac{3}{2} + \frac{S(S+1) - L(L+1)}{2J(J+1)}$$

$$= \frac{3}{2} + \frac{2 - 30}{2 \times 4(4+1)}$$

$$= \frac{3}{2} - \frac{28}{40}$$

$$= 0.8$$

$$\mu = 0.8\sqrt{4(4+1)} \text{ B.M.}$$

$$= 0.8\sqrt{20} \text{ B.M.}$$

$$= 3.58 \text{ B.M.}$$

This calculated value is very close to the experimental value 3.47 B.M.

The calculated magnetic moments by the above formula for lanthanoides have good agreement with observed values. For most lanthanoides the value of λ is about 1000 cm^{-1} . However λ value for Eu^{3+} and Sm^{3+} is about 300 cm^{-1} which is a small value. Therefore, the agreement for Eu^{3+} and Sm^{3+} is not very good.

For complexes in which λ value is small and separation between ground state and the first excited is small ($< kT$), spin-orbit coupling is negligible but spin and orbital contributions both are significant. In these complexes spin and orbital magnetic moments of electrons function independently. For electron spin only, $L=0$, $J=S$

$$\text{and } g = \frac{3}{2} + \frac{S(S+1) - 0}{2S(S+1)}$$

$$= \frac{3}{2} + \frac{1}{2} = 2$$

For orbital motion only,

$$S=0, \quad J=L$$

$$g = \frac{3}{2} + \frac{0 - L(L+1)}{2L(L+1)}$$

$$= \frac{3}{2} - \frac{L(L+1)}{2L(L+1)}$$

$$g=1$$

Thus, μ can be calculated by the expression:

$$\mu = \sqrt{4S(S+1) + L(L+1)} \text{ B.M.} \quad \dots(\text{ii})$$

In case of complexes of transition metals of 3d-series, the ligands diminish the orbital motion of electron round the nucleus and hence the magnetic moment due to orbital motion of electron is said to be quenched and the orbital contribution can be neglected i.e., $L=0$, $L(L+1)$ is also equals to zero.

Therefore, the magnetic moment may be considered to be arise only due to spins of unpaired electrons. The equation is reduced to

$$\mu = \sqrt{4S(S+1)} \text{ B.M.}$$

This equation is known as spin only formula for magnetic moment.

$$\mu_{\text{spin only}} = \sqrt{4S(S+1)} \text{ B.M.}$$

If number of unpaired electrons is n , then

$$S = \frac{n}{2}$$

and

$$\mu_S = \sqrt{n(n+2)} \text{ B.M. or } \mu_B \quad \dots(\text{iii})$$

$$1 \text{ B.M.} = \frac{eh}{4\pi m} = 9.27 \times 10^{-24} \text{ joule/tesla (JT}^{-1}\text{)}$$

where e is the electronic charge, h is Plank's constant and m is the mass of electron. The calculated values of spin only magnetic moments for 1, 2, 3, 4 and 5 unpaired electrons are 1.73, 2.83, 3.87, 4.90 and 5.92 respectively.

The calculated and experimental magnetic moments for complexes of transition elements of 3d-series are given in table 6.1.

The table 6.1 indicates that the experimental magnetic moments for complexes of first row transition metal ions do not agree with those calculated by equations (i) and (ii). Though there is good agreement between experimental magnetic moment and calculated by spin only formula (iii), however, in some cases, the experimental magnetic moment is higher than that of calculated by spin only formula. This is due to some orbital contribution.

The orbital contribution is possible only when an orbital will transform into an equivalent orbital by rotation. The t_{2g} orbitals (d_{xy} , d_{yz} and d_{zx}) can be transformed into each other by rotating about an axis by 90° . The e_g orbitals ($d_{x^2-y^2}$ and d_{z^2}) can not be transformed into one another because these have different shapes. Therefore, these orbitals have no orbital contribution. If all the t_{2g} orbital are singly occupied, then it is not possible to transform an orbital, say the d_{xy} orbital into d_{yz} or d_{zx} orbital because they already contain an electron with same spin as the incoming electron. Similarly, it is impossible to transform an t_{2g} orbital into others if all the t_{2g} orbitals are doubly occupied. Thus, t_{2g} orbitals with t_{2g}^3 and t_{2g}^6 configuration have no orbital contributions. The configurations other than t_{2g}^3 and t_{2g}^6 make orbital contributions to the magnetic moments of octahedral complexes. Therefore, in octahedral complexes the following configurations make orbital contributions:

$$d^1(t_{2g}^1 e_g^0), d^2(t_{2g}^2 e_g^0), d^6 \text{HS}(t_{2g}^4 e_g^2), d^7 \text{HS}(t_{2g}^5 e_g^2), d^4 \text{LS}(t_{2g}^4 e_g^0), d^5 \text{LS}(t_{2g}^5 e_g^0)$$

The following configuration in octahedral complexes of first series transition metal ions have no orbital contributions:

$$d^3(t_{2g}^3 e_g^0), d^4 \text{HS}(t_{2g}^3 e_g^1), d^5 \text{HS}(t_{2g}^3 e_g^2), d^8(t_{2g}^6 e_g^2), d^9(t_{2g}^6 e_g^3), d^6 \text{LS}(t_{2g}^6 e_g^0), d^7 \text{LS}(t_{2g}^6 e_g^1)$$

In the similar way, the tetrahedral complexes with the following configurations have orbital contributions :

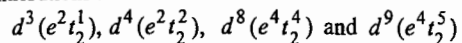

Table 6.1 : Experimental and Calculated Values of Magnetic Moments for Some High Spin and Low Spin Octahedral Complexes

Central Metal	No. of <i>d</i> -Electrons	High Spin Complexes		Low Spin Complexes			
		No. of Unpaired Electrons	μ (exp.) B.M.	μ (calc.) B.M.	No. of Unpaired Electrons	μ (exp.) B.M.	μ (calc.) B.M.
Ti ³⁺	1	1	1.73	1.73	—	—	—
V ³⁺	2	2	2.75–2.85	2.83	—	—	—
Cr ³⁺	3	3	3.70–3.90	3.88	—	—	—
Cr ²⁺	4	4	4.75–4.90	4.90	2	3.20–3.30	2.83
Mn ²⁺	5	5	5.65–6.10	5.92	1	1.80–2.10	1.73
Fe ³⁺	5	5	5.70–6.0	5.92	1	2.0–2.5	1.73
Fe ²⁺	6	4	5.10–5.70	4.90	0	—	—
Co ²⁺	7	3	4.30–5.20	3.88	1	1.8	1.73
Ni ²⁺	8	2	2.80–3.50	2.83	—	—	—
Cu ²⁺	9	1	1.70–2.20	1.73	—	—	—

In general, orbital contribution is possible in complexes in which the ground state of metal ion is electronically triply degenerate (e.g., T_{2g}). On the other hand, the orbital contribution is not possible in complexes in which the ground state of metal ion is electronically non-degenerate or doubly degenerate (e.g., A_{2g} or E_g).

A high spin octahedral complex of $d^7(t_{2g}^5 e_g^2)$ metal ion have calculated and experimental magnetic moments of 3.87 and 5.2 B.M. respectively. The higher value of experimental magnetic moment is expected because of the orbital contribution. For tetrahedral complex, $[\text{CoCl}_4]^{2-}$ ($e^4 t_2^3$), the calculated and experimental magnetic moments are 3.87 and 4.5 B.M. respectively. In this case the higher value of experimental magnetic moment is not due to orbital contribution. Although in most of the complexes with *A* or *E* ground state the quenching of the orbital contribution is expected to be complete and the experimental magnetic moment is very close to spin only magnetic moment and is temperature independent. However in some complexes there is the deviation of the experimental magnetic moment, μ from the spin only magnetic moment, $\mu_{s.o.}$. This is due to the temperature independent paramagnetism, TIP. In such cases, the first excited state, T (of same spin multiplicity as the ground state) mixes up with *A* or *E* ground state due to spin orbit coupling. For those complex in which spin-orbit coupling is significant, the following equation is used to calculate μ_{eff} :

$$\mu_{\text{eff}} = \mu_{s.o.} \left(1 - \frac{\alpha\lambda}{\Delta} \right)$$

Where α is a constant which depends upon the ground state and the number of *d*-electrons ($\alpha = 2$ for 2D and 5D , 4 for 3F and 4F and zero for 6S terms). Δ is the separation between ground and the excited state and can be obtained from electronic spectra, λ is the spin-orbit coupling constant and it is positive for d^1, d^2, d^3 and d^4 ions and negative for d^6, d^7, d^8 and d^9 ions. Since λ is positive for d^1, d^2, d^3 and d^4 ions and negative for d^6, d^7, d^8 and d^9 ions, therefore, the spin-orbit coupling gives low values of magnetic moments for first set of complexes and higher value of magnetic moments for the later.

The high spin octahedral complex of Mn^{2+} (d^5), say, $[\text{Mn}(\text{H}_2\text{O})_6]^{2+}$ for which ground state is ${}^6A_{1g}$, has no excited state of same spin multiplicity as that of the ground state. Therefore, mixing of ground state with any of the excited states due to spin-orbit coupling is not possible. Thus, there is no orbital contribution to μ_{eff} due to spin orbit coupling. Therefore, μ_{eff} is same as $\mu_{s.o.}$. Alternatively, since the ground state ${}^6A_{1g}$ arises from 6S term for which $\alpha = 0$, therefore, μ_{eff} is same as $\mu_{s.o.}$.

The ground state for low spin complex of d^6 -metal ion is also A_{1g} but all electrons are paired and hence the complex is diamagnetic.

High Spin–Low Spin Equilibria

Octahedral complexes of d^4, d^5, d^6 and d^7 of first series transition metal ions can either be high spin or low spin depending on the magnitude of ligand field splitting Δ_o and pairing energy, *P*. When the magnitude of Δ_o has an intermediate value in such a way that the two complexes (LS and HS) have same energy, the two complexes can exist in equilibrium. The low spin and high spin complexes of a metal cation can be distinguished by measurement of either magnetic susceptibility or magnetic moments. For high spin complexes $\Delta_o < P$ and for low spin complexes $\Delta_o > P$. If the difference in energy between Δ_o and *P* is small or negligible, the low spin and high spin can coexist in equilibrium. Consider the low spin,

3. The expected spin-only magnetic moments for $[\text{Fe}(\text{CN})_6]^{4-}$ and $[\text{FeF}_6]^{3-}$ respectively are :
 (a) 1.73 and 1.73 B.M. (b) 1.73 and 5.92 B.M.
 (c) 0.0 and 1.73 B.M. (d) 0.0 and 5.92 B.M.
4. The metal ion which is most likely to show the low spin-high spin equilibria in its complexes has the electronic configuration :
 (a) d^3 (b) d^4
 (c) d^6 (d) d^8
5. The effective magnetic moment is maximum for :
 (a) $\text{K}_4\text{Mn}(\text{CN})_6$ (b) K_2MnO_4
 (c) K_2MnCl_4 (d) KMnO_4
6. The complex with spin-only magnetic moment of ~ 4.9 B.M. is :
 (a) $[\text{Fe}(\text{H}_2\text{O})_6]^{2+}$ (b) $[\text{Fe}(\text{CN})_6]^{3-}$
 (c) $[\text{Fe}(\text{CN})_6]^{4-}$ (d) $[\text{Fe}(\text{H}_2\text{O})_6]^{3+}$
7. The compound *trans*- $[\text{Fe}(\text{o-Phen})_2(\text{NCS})_2]$ has a magnetic moment of 0.65 B.M. at 80 K, increasing with temperature to 5.2 B.M. at 300 K. The correct statement is :
 (i) These exists equilibrium between high spin and low spin complexes.
 (ii) There is significant change in UV-visible spectrum with temperature.
 (iii) Number of unpaired electrons at 80 K and 300 K are 1 and 4 respectively.
 (iv) Number of unpaired electrons at 80 K and 300 K are zero and 4 respectively.
 (a) Only (i) (b) Only (ii) and (iv)
 (c) Only (i), (ii) and (iv) (d) Only (i), (ii) and (iii)
8. The zero magnetic moment of octahedral K_2NiF_6 is due to :
 (a) low spin d^6 Ni(IV) complex
 (b) low spin d^8 Ni(II) complex
 (c) high spin d^8 Ni(II) complex
 (d) high spin d^6 Ni(IV) complex
9. In tetrahedral geometry, which one of the following sets of electronic configurations will have orbital contribution to the magnetic moment?
 (a) d^3, d^4, d^8 and d^9
 (b) d^1, d^6, d^7 and d^9
 (c) d^3, d^4, d^7 and d^9
 (d) d^1, d^3, d^4 and d^9
10. The experimental magnetic moment of $\text{K}_3[\text{Fe}(\text{CN})_6]$ is $2.3 \mu_B$ and is attributable to the :
 (a) spin-only value of a low-spin Fe
 (b) spin-only value of a high-spin Fe
 (c) low-spin Fe with orbital contribution
 (d) high-spin Fe with orbital contribution

11. The magnetic moment of $[\text{Ru}(\text{H}_2\text{O})_6]^{2+}$ corresponds to the presence of :
 (a) four unpaired electrons (b) three unpaired electrons
 (c) two unpaired electrons (d) zero unpaired electrons
12. Which of the following is diamagnetic in nature ?
 (a) $\text{Hg}[\text{Co}(\text{NCS})_4]$ (b) $\text{K}_3[\text{Fe}(\text{CN})_6]$
 (c) K_2PtCl_4 (d) $[\text{Cu}_2(\text{OAc})_4(\text{H}_2\text{O})_2]$
13. The complexes that would show paramagnetic behaviour is :
 (a) $[\text{MnO}_4]^-$ (b) $[\text{FeCl}_4]^-$
 (c) $[\text{Cu}(\text{1, 10-phenanthroline})_2]^+$ (d) $[\text{Fe}(\text{CN})_6]^{4-}$
14. The spin-only magnetic moment (in B.M.) value of $[\text{FeF}_6]^{3-}$ and $[\text{Co}(\text{CN})_5(\text{H}_2\text{O})]^{3-}$ respectively are :
 (a) 0 and 1.73 (b) 5.92 and 1.73
 (c) 4.47 and 1.73 (d) 5.92 and 3.87
15. Which two among $[\text{Fe}(\text{CN})_6]^{3-}$, $[\text{FeF}_6]^{3-}$, $[\text{Cu}(\text{bpy})_2]^{2+}$ and $[\text{Mn}(\text{acac})_3]$ (acac = acetyl acetonate anion) show the same spin-only magnetic moment?
 (a) $[\text{Fe}(\text{CN})_6]^{3-}$ and $[\text{FeF}_6]^{3-}$
 (b) $[\text{Fe}(\text{CN})_6]^{3-}$ and $[\text{Cu}(\text{bpy})_2]^{2+}$
 (c) $[\text{FeF}_6]^{3-}$ and $[\text{Mn}(\text{acac})_3]$
 (d) $[\text{Cu}(\text{bpy})_2]^{2+}$ and $[\text{Mn}(\text{acac})_3]$
16. Consider the two complexes (A) $[\text{Ni}(\text{H}_2\text{O})_6]^{2+}$ and (B) $[\text{Ni}(\text{NH}_3)_6]^{2+}$, the right statement is :
 (a) Complex (A) is diamagnetic and complex (B) is paramagnetic.
 (b) Complex (A) is paramagnetic and complex (B) is diamagnetic.
 (c) Both are paramagnetic.
 (d) Both are diamagnetic.
17. The actual magnetic moment shows a large deviation from the spin-only formula in the case of :
 (a) Ti^{3+} (b) V^{3+}
 (c) Gd^{3+} (d) Sm^{3+}
18. Of the following metal ions, which has the largest magnetic moment in its low spin octahedral complexes?
 (a) Fe^{3+} (b) Co^{3+}
 (c) Co^{2+} (d) Cr^{2+}
19. μ (calculated) for Cr^{2+} in high-spin and low-spin complexes should be :
 (a) 4.90 B.M. and 2.83 B.M., respectively
 (b) 4.90 B.M. for both
 (c) 1.73 B.M. and 2.83 B.M., respectively
 (d) 4.90 B.M. and 1.73 B.M. respectively

20. The correct d -electron configuration showing spin-orbit coupling is :

- (a) $t_{2g}^4 e_g^2$ ✓ (b) $t_{2g}^6 e_g^0$
 (c) $t_{2g}^3 e_g^0$ (d) $t_{2g}^3 e_g^2$

21. The plot of χT vs. T data of an ideal paramagnetic sample will :

- (a) pass through origin
 (b) be parallel to T -axis ✓
 (c) be parallel to χT -axis
 (d) parabolic nature

22. Magnetic moment of $[\text{RhF}_6]^{3-}$ in B.M. is:

- (a) 1.73 (b) 4.98
 (c) zero ✓ (d) 2.98

23. The species with highest magnetic moment (spin only value) is :

- (a) VCl_6^{4-} ✓ (b) $(\eta^5 - \text{C}_5\text{H}_5)_2\text{Cr}$ ✓
 (c) $[\text{Co}(\text{NO}_2)_6]^{3-}$ ○ (d) $[\text{Ni}(\text{EDTA})]^{2-}$

24. The magnetic moment of Co^{2+} in square planar complex is :

- (a) 1.73 B.M. ✓ (b) 3.87 B.M.
 (c) 4.87 B.M. (d) 5.87 B.M.

25. Red β -ketoenolate complex of Ni(II) is diamagnetic. The red complex turns bluish-green in the presence of water or amines and becomes paramagnetic. Which of the following structure is formed during the reaction ?

- (a) Tetrahedral (b) Square planar
 (c) Octahedral ✓ (d) Dodecahedral

26. The plot of χT versus T (where χ is molar magnetic susceptibility and T is the temperature) for a paramagnetic complex which strictly follows Curie equation is :

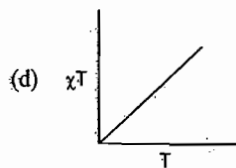
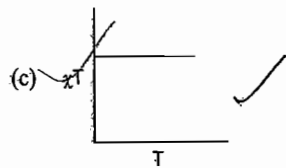
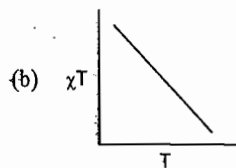
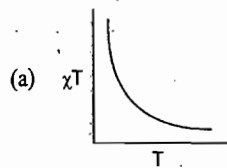

ANSWERS

- | | | | | | | |
|---------|---------|---------|---------|---------|---------|---------|
| 1. (a) | 2. (b) | 3. (d) | 4. (c) | 5. (c) | 6. (a) | 7. (d) |
| 8. (a) | 9. (a) | 10. (c) | 11. (d) | 12. (c) | 13. (b) | 14. (b) |
| 15. (b) | 16. (c) | 17. (d) | 18. (d) | 19. (a) | 20. (a) | 21. (b) |
| 22. (c) | 23. (b) | 24. (a) | 24. (a) | 25. (c) | 26. (c) | |

Subjective Questions

1. Explain the following :

- (i) The magnetic moments for octahedral and tetrahedral complexes of Ni^{2+} ion are 2.9-3.9 B.M. and 4.1 B.M. respectively whereas square planar complexes are diamagnetic.
- (ii) $[\text{NiCl}_4]^{2-}$ is paramagnetic whereas $[\text{PdCl}_4]^{2-}$ and $[\text{PtCl}_4]^{2-}$ are diamagnetic.
- (iii) The octahedral complexes of d^1, d^2, d^6 (HS) and d^7 (HS) configuration have orbital contribution to magnetic moment.
- (iv) Cr_2O_3 is highly paramagnetic yet it is not ferromagnetic.
- (v) $\text{K}_3[\text{CoF}_6]$ is paramagnetic whereas $\text{K}_2[\text{NiF}_6]$ is diamagnetic.
- (vi) Cu^{2+} ions are coloured and paramagnetic whereas Zn^{2+} ions are colourless and diamagnetic.
- (vii) The compound $[\text{NiCl}_2(\text{PPh}_3)_2]$ is red crystalline and diamagnetic. On heating, this compound is converted to green form of magnetic moment 3.20 B.M.
- (viii) The magnetic moment of $[\text{NH}_4]\text{V}(\text{SO}_4)_2 \cdot 12\text{H}_2\text{O}$ is 2.8 B.M. and it gives three absorption bands in its electronic spectrum at 17200 cm^{-1} , 25700 cm^{-1} and 36000 cm^{-1} in aqueous solution.
- (ix) The spin only magnetic moments of $\text{K}_3[\text{Fe}(\text{OX})_3]$ and $\text{K}_3[\text{Ru}(\text{OX})_3]$ are 5.91 B.M. and 1.73 B.M. respectively. (At. no. of Fe and Ru are 26 and 44 respectively).
2. What change in magnetic properties (if any) can be expected when NO_2^- ligands in $[\text{Co}(\text{NO}_2)_6]^{3-}$ are replaced by Cl^- ligands ?

3. Using the crystal field theory, calculate the magnetic moments in terms of B.M. of the following complexes :

(a) $[\text{CoF}_6]^{3-}$, (b) $[\text{MnBr}_4]^{2-}$, (c) $[\text{Co}(\text{NH}_3)_6]^{2+}$, (d) $[\text{Co}(\text{H}_2\text{O})_6]^{3+}$, (e) $[\text{Ni}(\text{CO})_4]$, (f) $[\text{Ru}(\text{NH}_3)_6]^{3+}$, (g) $[\text{RhF}_6]^{3-}$.

4. Using crystal field theory, explain the structure and magnetic properties of $[\text{NiCl}_4]^{2-}$, $[\text{Ni}(\text{CN})_4]^{2-}$ and $\text{Ni}(\text{CO})_4$.

5. Calculate spin-orbit coupling parameter (λ) for an octahedral Ni(II) complex exhibiting spin allowed $d-d$ band at 10750 cm^{-1} , 17500 cm^{-1} and 28200 cm^{-1} respectively. The experimentally determined magnetic moment is 3.2 B.M.

6. The magnetic moment of $3d$ -transition elements corresponds to spin only value. Explain.

7. The complex $[\text{FeF}_6]^{3-}$ is more paramagnetic than $[\text{Fe}(\text{CN})_6]^{3-}$. Explain on the basis of CFT.

8. The magnetic moment of $[\text{Fe}(\text{phen})_2(\text{NCS})_2]$ varies with temperature. The magnetic moments at 200 K and 50 K are 4.9 B.M. and 0 B.M., respectively. Write the d -electron configurations of Fe at both temperatures and give reason for the observed change in the magnetic moment.

(phen = 1, 10-phenanthroline)

□□□

7

Stability of Complexes and Reaction Mechanism

Stability of a complex compound is assigned to be its existence in aqueous solution with respect to its bond dissociation energy, Gibbs free energy, standard electrode potential or pH of the solution and rate constant or activation energy for substitution reactions. On account of these parameters stability of complexes is of two types.

Thermodynamic stability and
Kinetic stability

THERMODYNAMIC STABILITY

Thermodynamic stability of a complex refers to the tendency to exist under equilibrium conditions. In other words, we can say that the thermodynamic stability of a complex is the measure of tendency of a metal ion to form a particular complex ion. Thermodynamic stability is directly related to metal-ligand bond energies. The thermodynamic stability of a complex is given by formation constant (also called the stability constant which is the equilibrium constant for the complex ion formation).

In general complexes are not prepared from their components in gaseous phase but these are prepared in aqueous solution. In aqueous solution a metal cation gets hydrated to give, $[\text{M}(\text{H}_2\text{O})_x]^{n+}$ complex ion. When a ligand replaces water molecule from aqua complex ion, a new complex ion is formed and an equilibrium is established as shown below:

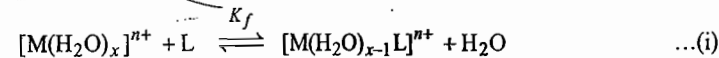

Where x is the number of water molecules, n is the oxidation number of the metal cation and L is the neutral and monodentate ligand. For simplicity, the above reaction can be written in generalized form as given below :



The equilibrium constant of the reaction is given by :

$$K_f = \frac{[\text{ML}]}{[\text{M}][\text{L}]} \quad \dots(\text{iii})$$

Concentration of H_2O is constant in dilute solution of the metal complex and it is incorporated into K_f . The water molecule which enters the bulk solution does not affect the equilibrium constant.

Trends in Stepwise (or Successive) Formation Constants

With a few exception, it is commonly observed that the magnitude of stepwise formation constant decreases steadily from K_1 to K_n

$$K_1 > K_2 > K_3 > \dots > K_{n-1} > K_n$$

This trend is illustrated by: (i) $Cd^{2+} - NH_3$ complex and (ii) $Cd^{2+} - CN^-$ complexes.

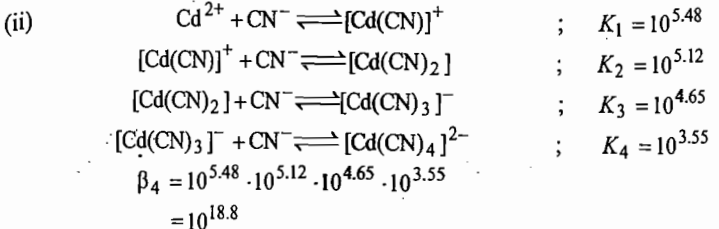
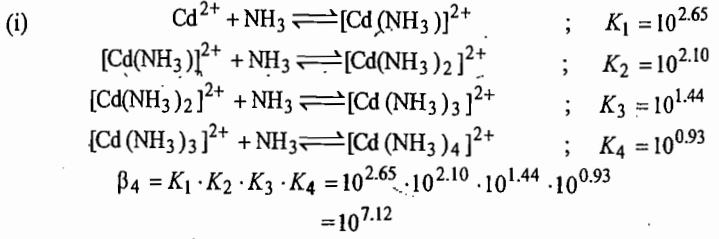

The steady decrease in the value of stepwise formation constants from K_1 to K_n is due to:
 (i) increase in number of ligands in coordination sphere causes to decrease the number of H_2O molecules to be replaced and thus the probability of replacement of water molecules decreases.
 (ii) electrostatic factors (when charged ligands are involved)
 (iii) steric hindrance increases with increase in number of ligands
 (iv) statistical factors.

However, in some cases it is found that $K_{n+1} > K_n$ because of **unusual structure change and change in electronic structure (i.e., change in spin state) of the metal ion.**

Change in electronic configuration causes the change in CFSE and the complex with more value of CFSE will be more stable and the equilibrium constant for that complex formation will be high.

Consider, for example, the formation of $[CdBr_4]^{2-}$ complex ion in aqueous solution. The formation of $[CdBr_4]^{2-}$ complex with Br^- exhibit four stepwise equilibrium or stepwise formation constants K_1, K_2, K_3 and K_4 . The order of stepwise formation constants is observed as follows: $K_1 > K_2 > K_3 < K_4$ which is contrary to $K_1 > K_2 > K_3 > K_4$.

Aqua complex of most of the M^{2+} ions are octahedral whereas the halo complexes of Cd^{2+} ion generally tetrahedral. The reactions for the formation of $[CdBr_4]^{2-}$ are:

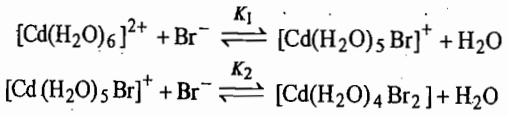

exceptions

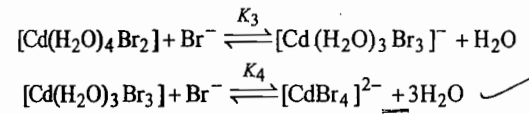

The last step is favoured by the release of three H_2O molecules and simultaneously there is unusual structural and electronic configuration change and thus $K_4 > K_3$.

Further consider another example of formation of $[Fe(bpy)_3]^{2+}$ from aqueous solution of Fe^{2+} ion.

The formation of $[Fe(bpy)_3]^{2+}$ complex ion with bipyridyl takes place in three steps and order of stepwise formation constants is $K_1 > K_2 < K_3$ which is contrary to $K_1 > K_2 > K_3$. The reactions for the formation of $[Fe(bpy)_3]^{2+}$ are:

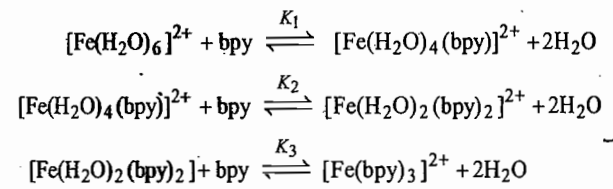

The two complexes $[Fe(H_2O)_4(bpy)]^{2+}$ and $[Fe(H_2O)_2(bpy)_2]^{2+}$ are high spin due to the presence of weak H_2O ligands having $t_{2g}^4 e_g^2$ electronic configuration with CFSE of $-0.4 \Delta_o$.

The complex $[Fe(bpy)_3]^{2+}$ formed in last step is low spin due to the presence of only strong bipyridyl ligands. This complex have electronic configuration $t_{2g}^6 e_g^0$ with CFSE of $-2.4 \Delta_o$. Therefore, there is change in electronic configuration and increase in CFSE. Hence, $K_3 > K_2$.

FACTORS AFFECTING STABILITY OF COMPLEXES

The factors which determine the stability of complexes are:

- (1) Nature of the Central Metal Ion
- (2) Nature of the Ligands
- (3) The Chelate Effect
- (4) Macrocyclic Effect
- (5) Resonance Effect
- (6) Steric Effect or Steric Hindrance

(1) Nature of the Central Metal Ion

Variations in the stabilities (i.e., stability constants) for a series of complexes of metals ions with a common set of ligands.

(a) **Charge on Metal Cation:** In general, a metal cation in higher oxidation state form more stable complexes than that of in lower oxidation states with a given ligand like X^- or NH_3 or H_2O . However there are a few exceptions with ligands such as $CO, PMe_3, o\text{-phenanthroline, bipyridyl, } CN^-$ which form more stable complexes with metals in lower oxidation states. These ligands have vacant π^* molecular orbitals for accommodation of lone pair of electrons donated by metal atom or cation and hence for π -back bonding. The electron rich CN^- is not only a poor π -acceptor but is also a good σ -donor and, therefore, forms complexes with metal atoms in higher oxidation state.

(b) **Size of Central Metal Cation** : For a given ligand and metals of same oxidation states, stability of the complexes increases with decrease in size of metal cations. For M^{2+} ions, the general trend in stability for complexes is :

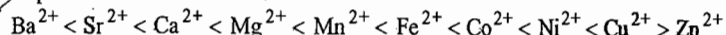

This trend in stability is known as **Irving-Williams series**.

This order of stability is consistent with **charge to radius ratio concept** because the radii decrease from Ba^{2+} to Cu^{2+} and then increases to Zn^{2+} . The order of size of depositive ions is :

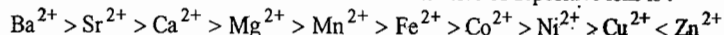

Since size of Zn^{2+} is larger than that of Cu^{2+} ion, therefore, stability of Zn^{2+} complex is lower than that of Cu^{2+} ion.

A plot of $\log K_f$ of complexes of M^{2+} ions with oxalate ions is shown in Figure 7.1. The $\log K_f$ values of Ba^{2+} , Sr^{2+} , Ca^{2+} , Mg^{2+} , Mn^{2+} (HS complex) and Zn^{2+} complexes lies on a line because their is no additional CFSE (i.e., CFSE = 0).

Though Cu(II) complexes have an additional e_g antibonding electron, they are more stable than Ni(II) complexes. This is due to the Jahn-Teller distortion. During the distortion two electrons are lowered in energy ($d_{x^2-y^2}$) while only one electron d_{z^2} orbital is raised by an equal amount in energy as

compared to octahedral field. It results in strong bonding of four ligands in the xy -plane of tetragonally distorted Cu(II) complex and increases the value of formation constant. The axial positions are weakly bound which is responsible for higher lability of complex.

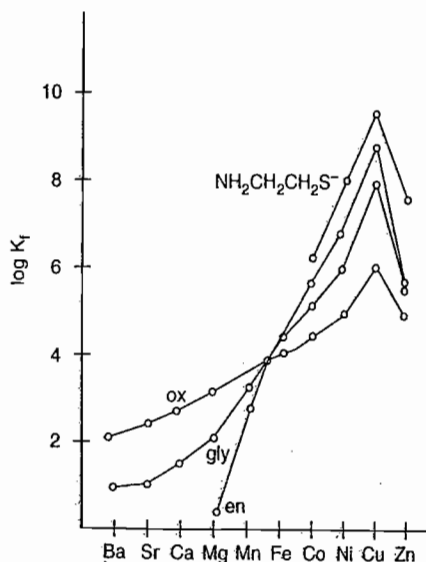

Figure 7.1 Variation of formation constants for M^{2+} ions of Irving-Williams series.

The value of stability constant for octahedral complexes of Mn^{2+} to Cu^{2+} ions increases more rapidly because these ions are additionally stabilized by CFSEs in octahedral field (Figure 7.1). The stability of octahedral complexes of Zn^{2+} is lower than that of Cu^{2+} ion because its CFSE is zero and it lies on the line representing the stabilities of Ba^{2+} , Sr^{2+} , Ca^{2+} , Mg^{2+} and Mn^{2+} ions where CFSE is also zero.

(c) **Class 'a' and Class 'b' Metals** : Ahrlund-*etal* in 1958 have classified the metals into three categories on the basis of their electron acceptor properties :

- (i) Class 'a' metal
- (ii) Class 'b' metals
- (ii) Borderline metals

(i) **Class 'a' metals** : Class a metal ions are characterized by high electropositive character (i.e. low electronegativities), small size, high oxidation states (+3 or higher) and no easily distorted outer electrons. These metal ions form their most stable complexes with ligands favouring electrostatic bonding. Class a metals form their most stable complexes with the first elements of group 15, 16 and 17 (e.g., N, O and F)

Class a metal ions include smaller ions from alkali metals, alkaline earth metals, lighter transition metals in high oxidation states (+3 or higher). Class a metals are also called as hard acids or hard metals.

Class a metals (or hard metals) are H^+ , Li^+ , Na^+ , K^+ , Be^{2+} , Mg^{2+} , Ca^{2+} , Sr^{2+} , Al^{3+} , Ga^{3+} , In^{3+} , Sc^{3+} , In^{4+} , Cr^{3+} , Mn^{3+} , Fe^{3+} , Co^{3+} , La^{3+} , Ce^{3+} , Gd^{3+} , Zr^{4+} , Hf^{4+} , Th^{4+} , U^{4+} , Pu^{4+} , etc.

The order of stabilities of complexes of class 'a' metals with the ligands having the following donor atoms is as follows :

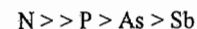
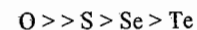
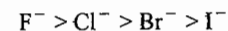

(ii) **Class 'b' metals** : Class 'b' metals are less electropositive, have relatively full d -orbitals and form their most stable complexes with ligands which, in addition to possess lone pairs of electrons, have empty π -orbitals available to accommodate electron pair from the d -orbitals of the metal. Class 'b' metals form stable complexes with ligands which have donor atoms from period 3 or subsequent periods. The metal ligand bond in these complexes is covalent. The order of stability is the reverse of class 'a' metals. The increase in availability of empty d -orbitals in heavier elements favours an increase in stability of the complexes. Class b metals are also called as soft acids or soft metals.

The order of stabilities of complexes with ligands having the following donor atoms is as follows :

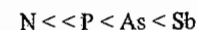
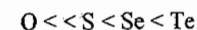
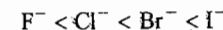

Furthermore, class 'b' metals form stable complexes with CO, *o*-phenanthroline, olefins because these have vacant π -orbitals of low lying energy.

Class 'b' metals are :

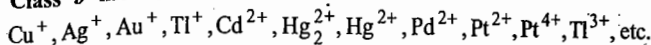

(iii) **Borderline Metals** : Borderline metals include divalent metal ions of 3d-series which are $\text{Mn}^{2+}, \text{Fe}^{2+}, \text{Co}^{2+}, \text{Ni}^{2+}, \text{Cu}^{2+}, \text{Zn}^{2+}$. For a given ligand order of stability of complexes is :

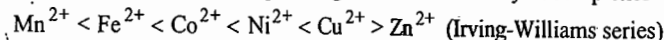

According to Pearson hard metals or acids prefer to bind to hard bases or hard ligand and soft acids or metals prefer to bind to soft bases or ligand.

(2) Nature of Ligands

(i) **Basic Character of Ligands** : In general, more is the basic character of ligands, more easily it can donate its lone pair of electrons to the central metal ion and hence greater is the stability of the complex formed. For example, for a given divalent (M^{2+}) 3d-series transition metal ion, order of stability of complex with $\text{NH}_3, \text{H}_2\text{O}$ and F^- is :

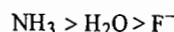

(ii) **Covalent Character** : Higher the covalent character, higher will be the stability of the complex. For example, order of stability and covalent character of complexes of Ag^+ with halogen is :

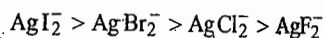

- Decreasing order of covalent character →
- Decreasing order of stability of complex →

(iii) **π - Bonding Capacity of Ligands** : The ligands like CO, CN^- , alkenes, phenanthroline, ipyridyl, $\text{R}_3\text{P}, \text{R}_2\text{S}$, etc have vacant π - or d-orbital to form π bond and hence form stable complexes with metals.

(iv) **Dipole Moment of Ligands** : For neutral ligands, higher the magnitude of dipole moment, higher will be the stability of the complex. For example, the order of stability of complexes of ligands having N as donor atom is :

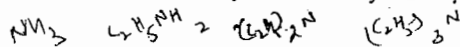
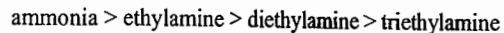

3) The Chelate Effect

The polydentate ligands (with more than one donor atoms) have geometries such that they can form more than one coordinate bond to the same metal cation, such ligands are called chelating ligands. These ligands, generally are non-linear. The complex formed by the coordination of a polydentate ligand to a metal cation is called a chelate complex or a chelate.

Chelating ligands form more stable complexes than the analogous monodentate ligands (containing the same donor atom). It means that chelated complexes are more stable than their non-chelated analogs. This effect is called as chelate effect.

Let us consider the formation of complexes from hydrated cadmium ion, $[\text{Cd}(\text{H}_2\text{O})_4]^{2+}$ with ethylamine (CH_3NH_2), ethylenediamine (en) and triethylenetetraamine (trien) ligands. Where ethylamine (CH_3NH_2), ethylenediamine ($\text{H}_2\text{N} - \text{CH}_2 - \text{CH}_2 - \text{NH}_2$) and triethylenetetraamine

$(\text{H}_2\text{N} - \text{CH}_2 - \text{CH}_2 - \text{NH} - \text{CH}_2 - \text{CH}_2 - \text{NH} - \text{CH}_2 - \text{CH}_2 - \text{NH}_2)$ are monodentate, bidentate and tetradentate ligands respectively.

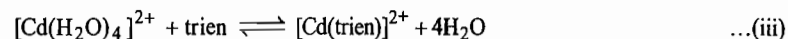
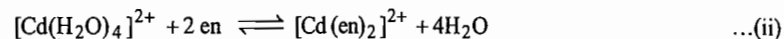
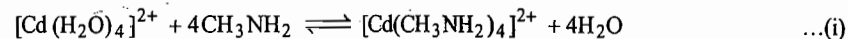

Structures of $[\text{Cd}(\text{CH}_3\text{NH}_2)_4]^{2+}$, $[\text{Cd}(\text{en})_2]^{2+}$ and $[\text{Cd}(\text{trien})]^{2+}$ are shown in Figure 7.2.

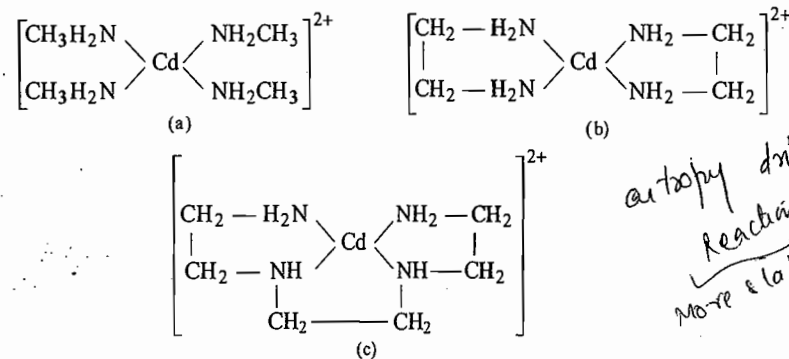
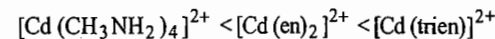

Figure 7.2: Structures of (a) $[\text{Cd}(\text{CH}_3\text{NH}_2)_4]^{2+}$, (b) $[\text{Cd}(\text{en})_2]^{2+}$, (c) $[\text{Cd}(\text{trien})]^{2+}$

$[\text{Cd}(\text{CH}_3\text{NH}_2)_4]^{2+}$ is a non-chelated complex ion whereas $[\text{Cd}(\text{en})_2]^{2+}$ and $[\text{Cd}(\text{trien})]^{2+}$ are chelated complex ions. Thus, $[\text{Cd}(\text{CH}_3\text{NH}_2)_4]^{2+}$ is less stable than $[\text{Cd}(\text{en})_2]^{2+}$ and $[\text{Cd}(\text{trien})]^{2+}$. It is also observed that $[\text{Cd}(\text{trien})]^{2+}$ is more stable than $[\text{Cd}(\text{en})_2]^{2+}$ chelate ion. Therefore, order of stability of these complex ions is :



The above order of stability of complexes can be explained in two ways :

1. In reaction : (i) a non-chelated complex ion $[\text{Cd}(\text{CH}_3\text{NH}_2)_4]^{2+}$ is formed and there is no net change in the number of molecules and entropy of reaction. On the other hand, in reaction (ii) and (iii) there is an increase in number of molecules and hence there is an increase in entropy of reaction. Since increase in number of molecules in reaction (iii) is greater than that of reaction (ii) Therefore, the increase in entropy is greater in reaction (iii) than reaction (ii). Since bonding in all the above three reactions is same, (i.e., $\text{Cd}^{2+} - \text{N}$ bond) thus, ΔH° in all the three reactions is same and negative in sign.

Thermodynamically, the stability of a complex is expressed in terms of ΔG° . For a stable complex ΔG° is negative and large.

$\Delta G^\circ = \Delta H^\circ - T\Delta S^\circ$

Since ΔH° in all the above three reactions is same and entropy increases from reaction (i) to (ii) to (iii) and thus, free energy change will be negative in the three reactions and increases from reaction (i) to (ii) to (iii).

A large negative value of ΔG° indicates the large value of stability constant (K) because

$$\Delta G^\circ = -RT \ln K$$

Thus, order of stability of the three complexes is :

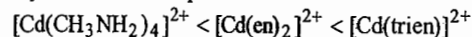

2. CH_3NH_2 , *en* and *trien* ligands are competing for the formation of complexes with Cd^{2+} ion in aqueous solution, the probability of either of them coordinating to the first site may be taken as equal. Once one end of *en* or *trien* is attached to Cd^{2+} ion, it is seen that the second amine group of *en* and *trien* is now greater in vicinity of Cd^{2+} ion than the second CH_3NH_2 ligand which is free to move randomly in the solution. Thus, probability of second amine group of *en* or *trien* to attach to Cd^{2+} ion is greater than that of monodentate ligand CH_3NH_2 . This indicates that formation constant is larger for the formation of chelates.

Further, the third and fourth donor atoms (amine groups) of *trien* are now greater in vicinity whereas the second *en* and the monodentate ligand CH_3NH_2 are moved freely and randomly in the solution. Thus, probability of third and fourth amine groups of *trien* to attach to Cd^{2+} ion is greater than that of *en* and CH_3NH_2 ligands. This indicates that stability of complex increases with the denticity of the ligand (denticity of a ligand is the number of donor atoms). In other words, we can say that the chelates in which one ligand form two or more rings are more stable than the complex in which one ligand form only one ring or no ring. The dependence of stability of chelates on the size of chelate ring is shown in Figure 7.3.

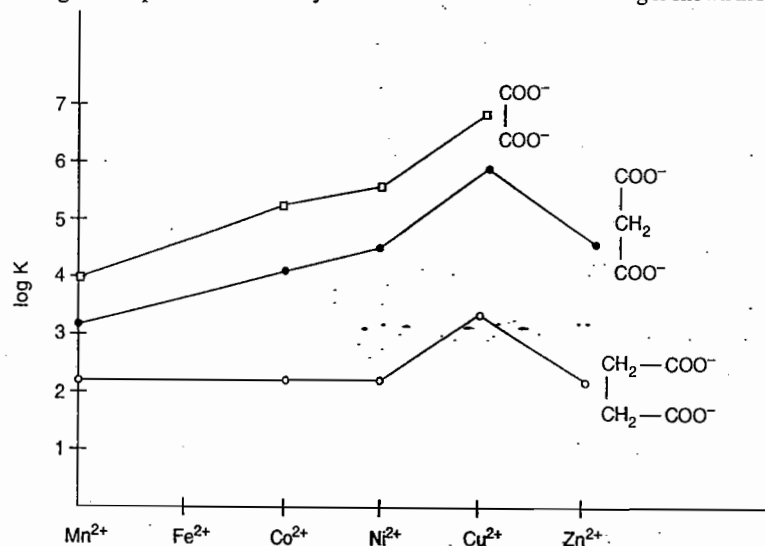

Figure 7.3: Dependence of complex stability on the size of the chelate ring.

In general, the chelates having five membered rings (including the metal) are more stable than six membered rings which are in turn more stable than the seven membered rings. Thus, the chelate effect weakens as the ring size increases. The chelate effect is usually most pronounced for 5- and 6-membered rings. Smaller rings generally involve excessive strain and become less stable. When the

chains and rings become much larger, the enhancement of local concentration (*i.e.*, vicinity of second donor atom of bidentate ligand) decreases and the resulting complex becomes less stable.

Furthermore, for the chelates formed by different bidentate ligands of same size with the same metal, the stability will be in the order, for example, oxalate < glycinate < ethylenediamine.

(4) Macrocyclic Effect

Macrocyclic ligands are large ring size compounds even without a metal atom present and the ligands have several donor atoms inside their rings to form coordinate bonds with a metal ion. Chlorophyll, heme and vitamin B_{12} all contain tetradentate macrocyclic ligands. As stated earlier, tetradentate chelating ligands form more stable complexes than analogous monodentate ligands and the macrocyclic ligands of appropriate size form more stable complexes than chelating ligands. There is a competition between a non-cyclic ligand and a macrocyclic ligand (a cyclic multi dentate ligand) having the same type of donor atoms and the complex formed by macrocyclic ligand will be more stable. This effect is called as macrocyclic effect. Chlorophyll, heme and vitamin B_{12} all contain tetradentate (four N-donor atoms) macrocyclic ligands.

(5) Resonance Effect

Resonance enhances the stability of complexes. For example, acetylacetonate anion ligand shows resonance and forms a stable chelated complex.

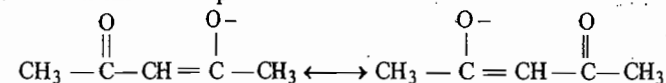

As a result of resonance the M—O bonds are equal in length and strength.

(6) Steric Effect or Steric Hindrance

If a bulky group is either attached to donor atom or to the atom adjacent to donor atom, the metal-ligand bond becomes weak and the stability of the complex decreases. This effect is called steric effect. For examples :

(i) Ethylene diamine ($\text{H}_2\text{N}-\text{CH}_2-\text{CH}_2-\text{NH}_2$) and *N,N*-tetramethylethylenediamine ($(\text{CH}_3)_2\text{N}-\text{CH}_2-\text{CH}_2-\text{N}(\text{CH}_3)_2$) both are bidentate ligands and form chelates with Ni^{2+} ion as shown in Figure 7.4.

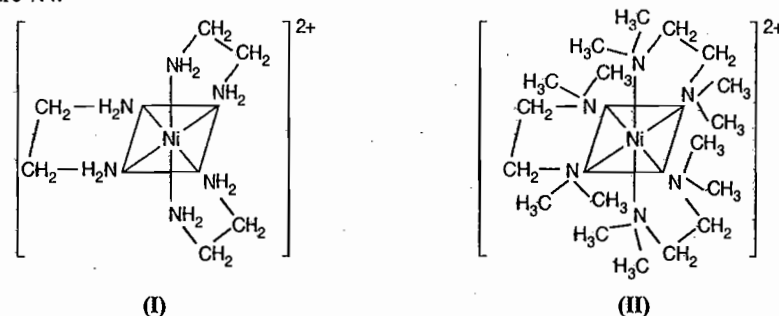

Figure 7.4

The complex (II) is less stable than (I) because in complex (II) the methyl groups attached to donor atoms create steric hindrance and decrease the stability of complex.

(ii) 8-hydroxy quinoline and 2-methyl-8-hydroxy quinoline both are bidentate ligands and form chelated complexes with Ni^{2+} ion as shown in Figure 7.5.

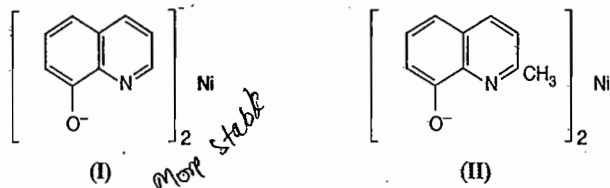

Figure 7.5

The complex (II) is less stable than complex (I) because in complex (II) a bulky group is attached to an atom adjacent to donor atom which causes a steric hindrance and lowers the stability of the complex.

The chelates containing chelating ligands with delocalized electronic structures are also stabilized by electronic effect in addition to entropy effect. The examples of such type of ligands are diimine ligands such as bipyridine and *o*-phenanthroline. These ligands stabilize the complexes because of their ability to act as σ -donors as well as π -acceptors. These ligands form π -bonds by overlapping their empty ring π^* orbitals with filled metal *d*-orbitals. An important example of such type of complexes is $[Ru(bpy)_3]^{2+}$ (Figure 7.6).

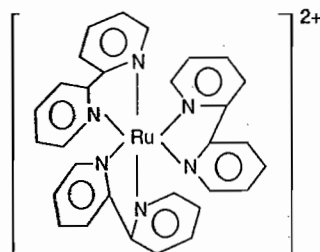

Figure 7.6

*By σ donor
IT acceptor*

KINETIC STABILITY : LABILITY AND INERTNESS

Kinetic stability refers to the rate of reaction which is governed by its activation energy, E_a or rate constant. Kinetic stability relates to how fast a compound reacts rather than to how stable it is. On the basis of rate of reaction, the term kinetic stability is classified into lability and inertness.

The complexes in which substitution of one or more ligands by another occurs readily are called labile complexes. The ability of a complex to give substitution reactions fastly is called the lability of that complex. Half-life ($t_{1/2}$) of labile complexes for substitution reactions is less than one minute. The complexes for which substitution reactions occur slowly (or not at all) are called inert complexes. Half-life of inert complexes towards substitution reactions is greater than one minute.

The inability or less ability of a complex to give substitution reactions with other ligands is called inertness of the complex.

THERMODYNAMIC STABILITY VERSUS KINETIC STABILITY

The thermodynamic terms (stable and unstable) refers to the tendency of a complex to exist under equilibrium conditions and the thermodynamic stability is related to the change in free energy, enthalpy

and entropy of reaction. The compound may be unstable with respect to a particular condition or reagent such as heat, light, acid or base.

The kinetic stability (lability and inertness) refers to the rate of reaction and mechanisms of reactions such as substitution and electron transfer reactions.

To illustrate the difference between thermodynamic and kinetic stability, consider the complexes: $[Ni(CN)_4]^{2-}$, $[Mn(CN)_6]^{3-}$ and $[Cr(CN)_6]^{3-}$. All these complexes are thermodynamically stable but kinetic stability is different. The rate of exchange can be measured when carbon-14 labeled cyanide ions are placed in solution with the complex. It is observed that $[Ni(CN)_4]^{2-}$ is labile, $[Mn(CN)_6]^{3-}$ is less labile and $[Cr(CN)_6]^{3-}$ is inert.

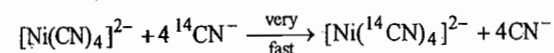

$$t_{1/2} = 30 \text{ sec}$$

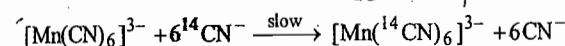

$$t_{1/2} = 1 \text{ hr}$$

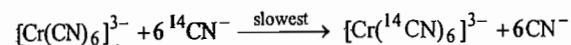

$$t_{1/2} = 24 \text{ days}$$

In contrast, for example $[Co(NH_3)_6]^{3+}$ complex ion is inert to substitution but it is thermodynamically unstable in acid solution.

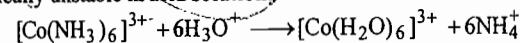

The formation constant for this reaction is very large ($\sim 10^{30}$). This indicates that the complex $[Co(NH_3)_6]^{3+}$ is unstable in acidic solution. On the other hand, it takes several days at room temperature to form $[Co(H_2O)_6]^{3+}$ complex i.e., the rate of this reaction is slow and hence the complex $[Co(NH_3)_6]^{3+}$ is kinetically inert.

The above discussion indicates that thermodynamic terms (stable and unstable) are not related to kinetic terms (lability and inertness).

SUBSTITUTION REACTION IN OCTAHEDRAL COMPLEXES

Substitution reactions involve the replacement of one ligand in coordination sphere by another without any change in coordination number and oxidation state of metal cation. For example, octahedral complex containing a metal cation or atom bound to five inert ligands (say L) and one labile ligand (say X) which is to be replaced by an incoming ligand (Y). The overall reaction is shown below:

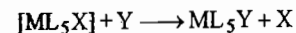

Since ligands behave as nucleophile, therefore, these reactions are called nucleophilic substitution reactions or ligand substitution reactions.

Mechanism in Octahedral Complexes

The mechanism of a reaction is the sequence of elementary reactions involved in a reaction. Substitution reactions in octahedral complexes take place through either of the following three mechanisms:

1. Dissociative (D) Mechanism S_N1
2. Associative (A) Mechanism S_N2
3. Interchange (I) Mechanism

1. Dissociative (D) Mechanism: In the dissociative mechanism, there is a step in which an intermediate of reduced coordination number is formed *i.e.*, the M-X bond is fully broken before the M-Y bond begins to form.

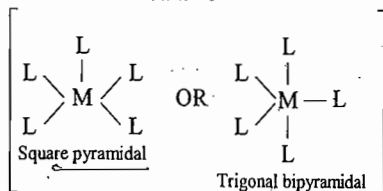
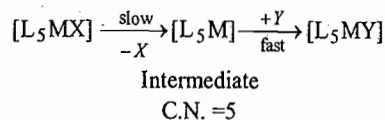

where L is an inert ligand, X is labile (leaving ligand) and Y is the entering ligand.

The rate determining step is the slowest elementary reaction. The rate of overall substitution reaction depends only on the concentration of the original complex, $[ML_5X]$ and is independent of the concentration of the incoming ligand Y.

$$\text{Rate} = k [ML_5X]$$

This reaction is of first order in $[ML_5X]$ and $[ML_5X]$ gets dissociated is rate determining step. Thus, this reaction is also called dissociative S_N1 mechanism (substitution, nucleophilic first order).

Most substitution reactions in octahedral complexes takes place by dissociative mechanism in which an intermediate of coordination number = 5 (most probable square pyramid) is formed.

2. Associative (A) Mechanism: An associative mechanism involves a step in which an intermediate is formed with a higher coordination number than the original complex *i.e.*, the incoming ligand Y directly attacks the original complex to form an intermediate with a coordination number = 7 in the rate determining step. The rate determining step is slow.

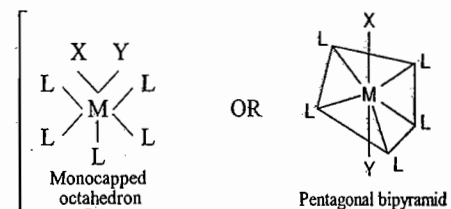
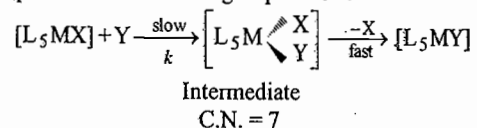

This intermediate might be expected a monocapped octahedral structure in which the X and Y ligands share one of the octahedral sites or a pentagonal bipyramidal structure. The second step is the dissociation of ligand X to give the product. The rate of reaction depends on the concentration of both ML_5X and Y. Therefore,

$$\text{Rate} = k [ML_5X][Y]$$

This reaction is of second order and this associative mechanism is also called S_N2 (Substitution, nucleophilic, second order) mechanism.

3. Interchange (I) Mechanism: This mechanism takes place in one step without forming a fairly stable intermediate, instead the leaving and entering ligands exchange in a single step forming an activated complex. The interchange mechanism is common for many reactions of octahedral complexes. The activated complex (also called as transition state) has very little or no stabilization energy and immediately passes on to products or reverts to the reactants.

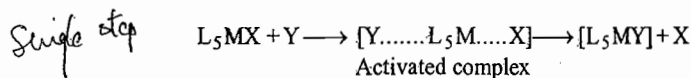

In this mechanism the M-X bond begins to break and starts to move away from the metal and the M-Y bonds begins to form simultaneously and Y moves into the coordination sphere and no stable intermediate is formed.

Interchange mechanism is subdivided into two categories:

- (i) Interchange Dissociative (I_d)
- (ii) Interchange Associative (I_a)

(i) Interchange Dissociative Mechanism (I_d): The M-Y bond begins to form before the M-X bond is fully broken but the M-X bond breaks preferentially and the interchange is closer to a dissociative than to an associative mechanism, and no detectable intermediate appears.

(ii) Interchange Associative Mechanism (I_a): The M-X bond begins to break before the M-Y bond is fully formed but the M-Y bond forms preferentially and the interchange is closer to associative and no detectable intermediate appears.

REACTION PROFILES FOR DISSOCIATIVE, ASSOCIATIVE AND INTERCHANGE MECHANISMS

A plot of free energy *versus* reaction pathway is called reaction profile or energy profile.

In an interchange mechanism a reactant absorbs energy and combines with the incoming ligand and form an activated complex or transition state before the formation of product. The energy difference between the reactants and transition state is called energy of activation, E_a . The transition state lies on

the top of the reaction profile (like on top of the hill) and at this point reactant converts into product without no hesitation [Figure 7.7(a) and (b)].

If the activation energy is high, then the rate determining step is slow and if the energy of activation is low, rate determining step is fast.

In dissociative (D) or associative (A) mechanism an intermediate of lower coordination number (= 5) or higher coordination number (= 7) is formed before the formation of product. Because an intermediate is more stable than a transition state, therefore, it will lie in a valley (or bit) in energy profile [Figure 7.7(c) and (d)]. The stability or existing time of an intermediate in a valley depends on how high the energy walls around the intermediate are :

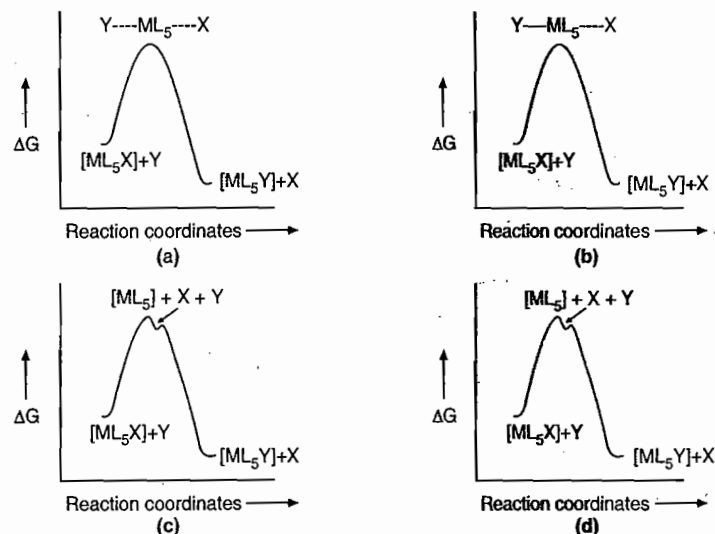

Figure 7.7. Energy Profile for : (a) Interchange dissociative (I_d), (b) Interchange associative (I_a), (c) dissociative (D), (d) Associative (A).

INTERPRETATION OF LABILITY AND INERTNESS OF TRANSITION METAL COMPLEXES

1. On the Basis of Valence Bond Theory : According to VBT, transition metals form, two types of octahedral complexes : (i) outer orbital complexes and (ii) inner orbital complexes. In outer orbital complexes, the outer nd -orbitals are involved in sp^3d^2 -hybridization and in inner orbital complexes the inner $(n-1)d$ -orbitals are involved in d^2sp^3 -hybridization. Thus, the M-L bonds in outer orbital complexes is larger, weaker and higher in energy whereas in inner orbital complexes the M-L bond is shorter, stronger and lower in energy. Thus, the transition metal octahedral complexes undergoing substitution reactions through dissociative mechanism would be labile if the M-L bond is weak and would be inert if M-L bond is comparatively strong. Thus, according to VBT, if the transition metal complexes undergoing substitution reactions through dissociative mechanism then all outer orbital complexes are labile and all inner orbital complexes are inert.

Further it is observed that the complexes either inner orbital or outer orbital are labile if they have vacant, low lying unhybridized metal d -orbitals (below hybrid orbitals). These vacant orbitals act as a point of attack for an incoming ligand. Such complexes undergo substitution through associative mechanism in which an intermediate of higher coordination number (= 7) is formed. On the other hand, the inert complexes have electron density in the unhybridized metal $(n-1)d$ -orbitals. Some example of labile and inert complexes are shown in Table 7.1 :

Table 7.1

Compound	Kinetic Stability	No. of Unpaired Electrons	Hybridization
$[V(NH_3)_6]^{3+}$	Labile	2	d^2sp^3 -hybridization
$[Cr(CN)_6]^{3-}$	Inert	3	d^2sp^3 -hybridization
$[MnCl_6]^{3-}$	Labile	4	sp^3d^2 -hybridization
$[Co(CN)_6]^{3-}$	Inert	0	d^2sp^3 -hybridization

Though, there are some exceptions which can be explained on the basis of CFT. For example, according to VBT $d^6(HS)$, $d^7(HS)$ and d^9 octahedral complexes have no low lying vacant d -orbital and, therefore, these complexes should be inert. But experimentally it is observed that these complexes are labile.

2. On the Basis of Crystal Field Theory : Octahedral complexes undergo substitution reactions through either dissociative (SN^1) or associative (SN^2) mechanisms. The SN^1 reactions take place through the lower energy square pyramidal intermediate instead of higher energy trigonal bipyramidal intermediates. On the other hand, the SN^2 reactions occurs through pentagonal bipyramidal intermediate (CN = 7). There is a change in CFSE on going from octahedral to square pyramidal (C.N. = 5) or pentagonal bipyramidal (C.N. = 7) intermediate. If there is loss in CFSE (represented by negative sign), then the complex will be inert. Higher the loss in CFSE, more will be inertness of the complex. If there is no loss in CFSE (*i.e.*, change in CFSE is zero or positive), the complex will be labile. The change in CFSE is called as crystal field activation energy (CFAE). But it is difficult to assign the CFSE of the intermediate or complex without exact knowledge of its structure. Basolo and Pearson have calculated the values of CFSE for low spin and high spin square pyramidal and pentagonal bipyramidal intermediates. These values are given the table 7.2.

DOL DI

Table 7.2 Change in CFSE* on going from Octahedral Complex to Intermediate of C.N. 5 and 7

d^n	High Spin		Low Spin	
	C.N. = 5	C.N. = 7	C.N. = 5	C.N. = 7
d^0	0	0	0	0
d^1	+0.57	+1.28	+0.57	+1.28
d^2	+1.14	+2.56	+1.14	+2.56
d^3	-2.00	-4.26	-2.00	-4.26
d^4	+3.14	-1.07	-1.43	-2.98
d^5	0	0	-0.86	-1.70
d^6	+0.57	+1.28	-4.00	-8.52
d^7	+1.14	+2.56	+1.14	-5.34
d^8	-2.00	-4.26	-2.00	-4.26
d^9	+3.14	-1.07	+3.14	-1.07
d^{10}	0	0	0	0

* CFSE in unit of D_0 or $\Delta/10$. A '+' sign indicates a gain in CFSE during the process and a '-' sign indicates a loss in CFSE.

Since the substitution reactions in most of the octahedral complexes proceed through square pyramidal intermediate (C.N. = 5) i.e., dissociative mechanism, comparison of inertness or lability is made on the basis of change in CFSE from octahedral complex to square pyramidal intermediate.

The order of lability of complexes of tripositive metal cations of 3d-series is:

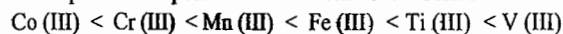

for SN^1 mechanism.

For isoelectronic metal cations, the lability of complex decreases with increase in charge on metal cation because high charge strengthens the M-L bond and reduces the lability. For example, $\text{Cr}^{3+} (d^3)$ complexes are more inert than $\text{V}^{2+} (d^3)$ complexes. Similarly $\text{Fe}^{3+} (d^5)$ complexes are more inert than analogous complexes of $\text{Mn}^{2+} (d^5)$.

It is observed that inertness of analogous complexes of isoelectronic metal cation increases on descending within the group because: (i) 4d- and 5d-series metal cations are larger than the 3d-series metals in the same group, there is less steric hindrance among the ligands round the metal cations and, therefore, less tendency for a given ligand to move from the coordination sphere. (ii) 4d- and 5d-series metal cations are larger and use 4d- and 5d-orbitals in the formation of sigma bonds with ligands. Since 4d- and 5d-orbitals are diffused (i.e., larger), so these orbitals extend towards ligands and overlap with ligands-orbitals more effectively and thus a strong M-L bond is formed and it is difficult to break in the rate determining step of dissociative reaction.

For example, order of inertness of analogous complexes of group 9 and 10 is:

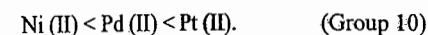
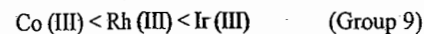

It is to be noted that $\text{Cu}^{2+} (d^9)$ and $\text{Cr}^{2+} (d^4)$ hydrated complexes have +2 charges and there is significant gain in CFSE on going from octahedral to intermediate. These complexes have fastest water exchange because two water molecules above and below the square plane are far apart from the Cu^{2+} ion as compared to other four water molecules. Therefore, these two water molecules above and below the square plane react rapidly.

Other Factors Affecting the Lability of a Complex

(1) **Geometry of the Complex:** The complexes of C.N. 4 undergo substitution reactions more rapidly than analogous compounds of C.N. 6. For example, $[\text{Ni}(\text{CN})_4]^{2-}$ give exchange reaction with $^{14}\text{CN}^-$ more rapidly than $[\text{Mn}(\text{CN})_6]^{3-}$ and $[\text{Co}(\text{CN})_6]^{3-}$ complexes. The greater lability of square planar complex, $[\text{Ni}(\text{CN})_4]^{2-}$ is due to the reason that there is enough room round the metal cation for the entry of incoming ligand into the coordination sphere to form activated complex. This fifth ligand enhances the rate of removal of one of the four ligands already present in the coordination sphere.

(2) **Oxidation State of Central Metal Cation:** Higher the oxidation state of central metal cation, lower will the lability of the complex.

For example:

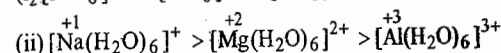
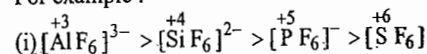

Order of lability

Size of inert \propto charge

(3) **Ionic Radius:** Lability of complex increases with increase in ionic radius. For example:

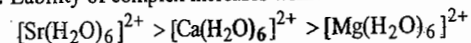

EVIDENCE FOR DISSOCIATIVE (SN^1) MECHANISM

The most preferred mechanism for substitution reactions in octahedral complexes is dissociative mechanism. However associative reactions are also possible in octahedral substitution but are much less common. Some evidence which support the dissociative mechanism are:

- (1) the rate of exchange of water molecules.
- (2) anation reactions.
- (3) aquation or hydrolysis reactions.

(1) Water Exchange

When water molecules in the coordination sphere are exchanged with isotopically labeled bulk water (H_2O^{18}), the process is called water exchange.

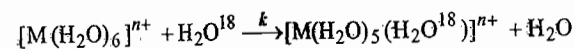

The rate of water exchange depends on the ratio of charge on metal cation to its ionic radius. This ratio charge/ionic radius is called charge density. The charge density of metal cations increases with increasing charge and decreasing ionic radius. As the charge density increases, M—OH₂ bond strength increases because high charge density (i.e., high charge and small size) causes greater electrostatic attraction between metal cation and the water molecules. Within a given group, all the cations have same charge but the size increases on descending the group. Thus, on moving down the group, the size increases and charge density decreases and the M—OH₂ bond becomes larger and weaker and breaks more easily. The breaking of M—OH₂ bond is the rate-determining step in dissociative mechanism i.e., SN¹ mechanism. Thus, these reactions are of first order.

Metal ions are classified into four categories based on the rate of exchange of coordinated water :

Class I : The rate of exchange of water is very fast. Rate constants for water exchange are of the order of 10⁸ s⁻¹. These reactions are diffusion controlled reactions. Ions that include in this class are alkali metals, alkaline earth metals (except Be²⁺ and Mg²⁺), group 12 elements (except Zn²⁺), Cr²⁺ and Cu²⁺ from first transition series.

Class II : The rate of exchange of water is fast but slower than that of class I metals. The rate constants for water exchange are in the range of 10⁴ to 10⁸ s⁻¹. The metal ions that include in this class are dipositive transition metals from first transition series (except V²⁺ which is slower and Cr²⁺ and Cu²⁺ which are in class I), Mg²⁺ and Ti³⁺ and the trivalent lanthanoids.

Class III : Rate of water exchange is comparatively smaller than that of class I and II metal ions. The rate constants for water exchange are 1 to 10⁴ s⁻¹. This class includes most of the trivalent transition metal ions of first transition series, Be²⁺, V²⁺, Al³⁺ and Ga³⁺ ions.

Class IV : The rate of exchange of water is very small and these are inert hydrated complexes. The rate constants for water exchange are 10⁻⁶ to 10⁻² s⁻¹. This class includes Cr³⁺, Co³⁺, Rh³⁺, Ru³⁺, Ru²⁺, Ir³⁺ and Pt²⁺ ions.

The rate of water exchange in hexaqua ions follow the order :

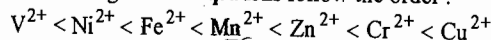

and

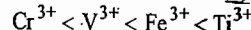

Handwritten notes:
 Mn²⁺ < Zn²⁺ < Cr²⁺ < Cu²⁺
 Fe³⁺ < V³⁺ < Fe³⁺ < Ti³⁺

(2) Anation Reactions

In these reactions an anion replaces an aqua (H₂O) ligand from coordination sphere of a hydrated complex.

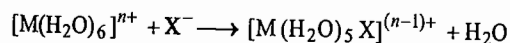

Such type of reactions may proceed by either dissociative or associative mechanisms but most evidence favour the dissociative mechanism. The classic examples in the support of dissociative mechanism are :

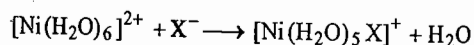

Where X⁻ = F⁻, SCN⁻ and CH₃COO⁻.

The rate constant of these reactions (8 × 10³ s⁻¹, 6 × 10³ s⁻¹ and 30 × 10³ s⁻¹) suggest, that the rate determining step is Ni²⁺ — OH₂ bond breaking.

Another example of dissociative mechanism is :

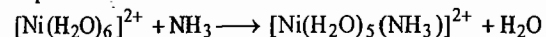

For this reaction, the rate determining step is Ni²⁺ — OH₂ bond breaking and the rate constant for rate determining step is 4 × 10³ s⁻¹.

(3) Aquation or Hydrolysis Reactions

The substitution reactions in which a ligand is replaced by water molecule are called aquation reactions or hydrolysis reactions. The aquation reactions may be carried out either in acidic or neutral or basic medium.

If the hydrolysis is carried out in acidic medium, then it is called acid hydrolysis and in this reaction a ligand is replaced by H₂O molecule. If the hydrolysis is carried out in basic medium (pH > 8) then it is called base hydrolysis and in this reaction a ligand is replaced by OH⁻ group.

At intermediate value of pH the reaction is simply called as hydrolysis and both path will be available.

For example, aquation of the ligand X⁻ in ammine complexes of Co (III) in acidic (pH < 3) and basic (pH > 8) medium is shown below :

At pH < 3 :

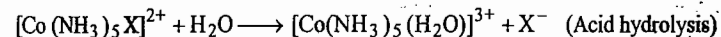

where X⁻ = F⁻, Cl⁻, Br⁻, I⁻, NCS⁻, NO₃⁻

At pH > 8 :

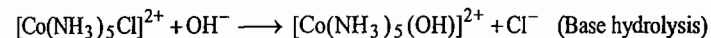

(I) Acid Hydrolysis of Cobalt (III) Ammine Complexes

Ammine complexes of cobalt (III) have been most widely studied. In acid hydrolysis, water molecule replaces a ligand (say X⁻) from the coordination sphere. Since entering ligand (H₂O) is present in constant concentration, the rate law, therefore, does not contain (H₂O). Thus, it implies that, the hydrolysis reactions are of first order.

$$\text{Rate} = k_a [Co(NH_3)_5X]^{2+}$$

where k_a is the rate constant for acid hydrolysis.

This rate law does not indicate whether these reactions proceed by SN¹ or SN² mechanisms. However, it has been observed that most acid hydrolysis reactions of octahedral complexes proceed by dissociative process.

There are some evidence which support the dissociative mechanism for acid hydrolysis of Co(III) ammine complexes.

(i) **Effect of Leaving Group :** The bond strength of a metal-ligand bond plays a major role in determining the dissociation rate of the leaving ligand. As the metal-ligand bond strength increases, it is difficult to remove the ligand and hence the rate of substitution reaction decreases. The rate of reaction is related to the rate constant (k_a) and the smallest value of k_a have the slowest rate of reaction and the M—L bond strength is related to equilibrium constant (K). Large value of equilibrium constant (K)

Handwritten notes:
 [Co(H₂O)]²⁺
 Co(OH)₂ - 220

Handwritten note:
 Acid hydrolysis first order

implies that the ligand is tightly bound to metal and corresponding to large value of equilibrium constant M-L bond dissociation is difficult and the value of k_a is small *i.e.*, rate of reaction is slow. Thus, it is seen that the rate constant k_a is linearly related to the equilibrium constant (K).

Mathematically,

$$\ln k_a = \ln A - \frac{E_a}{RT}$$

(Kinetic equation)

$$\ln K = -\frac{\Delta H^\circ}{RT} + \frac{\Delta S^\circ}{R}$$

(Thermodynamic equation)

If pre-exponential factor A and entropy ΔS° are constant and the energy of activation, E_a depends on the enthalpy of reaction, ΔH° then $\ln k_a$ and $\ln K$ are related linearly.

If a graph is plotted between $\ln k_a$ and $\ln K$ for various $[\text{Co}(\text{NH}_3)_5\text{X}]^{2+}$ cations (where $\text{X} = \text{NO}_3^-, \text{I}^-, \text{Br}^-, \text{Cl}^-, \text{F}^-$ etc), a straight line is obtained (Figure 7.8).

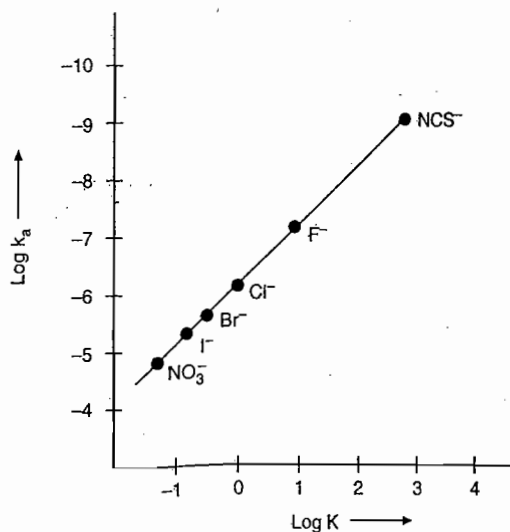
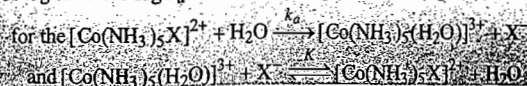

Figure 7.8 A plot of $\log K$ versus $\log k_a$ for a variety of pentaammine (ligand)cobalt(III) complex cations



From the Figure 7.8 it has been observed that the reactivity of X^- groups decreases in the order : $\text{NO}_3^- > \text{I}^- > \text{Br}^- > \text{Cl}^- > \text{F}^- > \text{NCS}^-$

The Figure 7.8 shows that the stronger the M-L bond, slower is the rate of aquation.

It is experimentally observed that most of the acid hydrolysis reactions proceeds by dissociative (SN^1) mechanism.

(ii) **Charge Effect** : The higher positive charge on complex cation makes bond breaking between metal and ligand more difficult and, therefore, rate of dissociation will be slower. For example, aquation of $[\text{Co}(\text{NH}_3)_5\text{Cl}]^{2+}$ is slower than that of *trans* $[\text{Co}(\text{NH}_3)_4\text{Cl}_2]^+$.

Chelation provide stability
So less aquation rate-

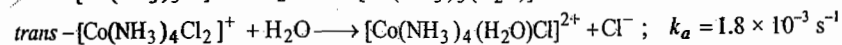
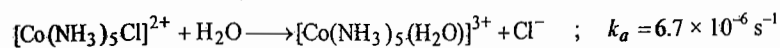

An increase in rate constant as charge decreases on complex cation often has been accepted as evidence of dissociative mechanism.

(iii) **Effect of Chelation** : Let us consider the aquation of the non-chelated complex, $[\text{Co}(\text{NH}_3)_5\text{Cl}]^{2+}$ and a chelated complex, $[\text{Co}(\text{en})_2(\text{NH}_3)\text{Cl}]^{2+}$ by dissociative mechanism.

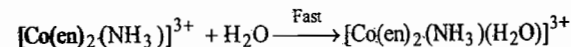
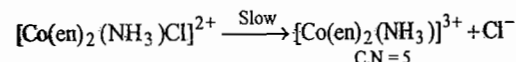
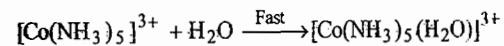
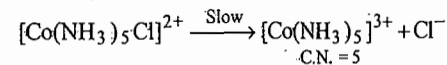

It is seen that the intermediate obtained from the chelated complex is larger in size than that of the intermediate obtained from non-chelated complex. There is less attraction between larger intermediate and water molecules than between smaller intermediate and water molecules. Thus, a chelated complex undergoes aquation at slower rate than a non-chelated complex. In a similar way a larger chelated complex undergoes aquation at a slower rate than that of smaller chelated complex.

(iv) **Steric Hindrance** : If H-atom(s) either of carbon or nitrogen atoms of 'en' group of *trans* $[\text{Co}(\text{en})_2\text{Cl}_2]^+$ are replaced by the alkyl groups like CH_3 , C_2H_5 etc, the ligand becomes more bulky. It is observed that more is the steric hindrance (*i.e.*, crowding), the faster is the rate of aquation. Now the question is that the aquation is consistent with either a dissociative or associative mechanism.

If the aquation takes place by associative mechanism, due to steric hindrance it is difficult to reach the water molecule to the metal cation to form seven coordinate intermediate and, therefore, the associative mechanism is not possible.

On the other hand, if the strained complex undergoes aquation reaction by dissociative mechanism, the steric hindrance round the metal cation forces the chloride ligand out of the coordination sphere and an intermediate of five coordinate is formed. Since five coordinate intermediate is less strained than the original complex, therefore, the aquation proceeds by dissociative mechanism. Thus, an increase in steric hindrance favours a dissociative mechanism.

Base Hydrolysis

Replacement of a ligand from coordination sphere by OH^- is called base hydrolysis. The most suitable mechanism has been given by Garrick which is called as SN^1CB (substitution, nucleophilic, first order, conjugate base) mechanism.

The mechanism of $\text{Co}(\text{III})$ complexes containing amine ligands is shown below :

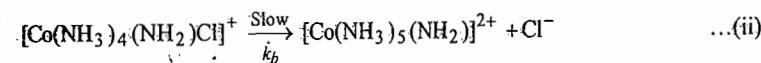
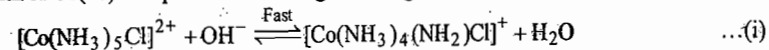



The first step involves the removal of proton from NH_3 group by OH^- in a rapid acid-base equilibrium forming amide complex ion of lower charge (a conjugate base of original amine complex). Then this conjugate base dissociates to loss Cl^- in slow step [reaction (ii)] and finally it form the hydroxo complex rapidly [reaction (iii)]. Thus, the second step is the rate determining step.

Q In $\text{Co}(\text{III})$ complexes containing amine ligands, the rate of base hydrolysis is million times faster than acid hydrolysis because:

(i) $k_b > k_a$

where k_b is base hydrolysis rate constant and k_a is acid hydrolysis rate constant.

(ii) The amido complex (*i.e.*, conjugate base) has lower charge than its original complex. Thus, this charge effect enhances the removal of labile ligand (*i.e.*, Cl^-).

(iii) In amido complex (*i.e.*, conjugate base) the NH_2 ligand has the tendency to form π -bond by donating its lone pair of electrons to the metal cation, $\text{Co}(\text{III})$ as shown in the Figure 7.9.

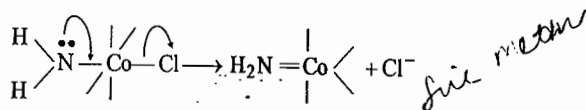
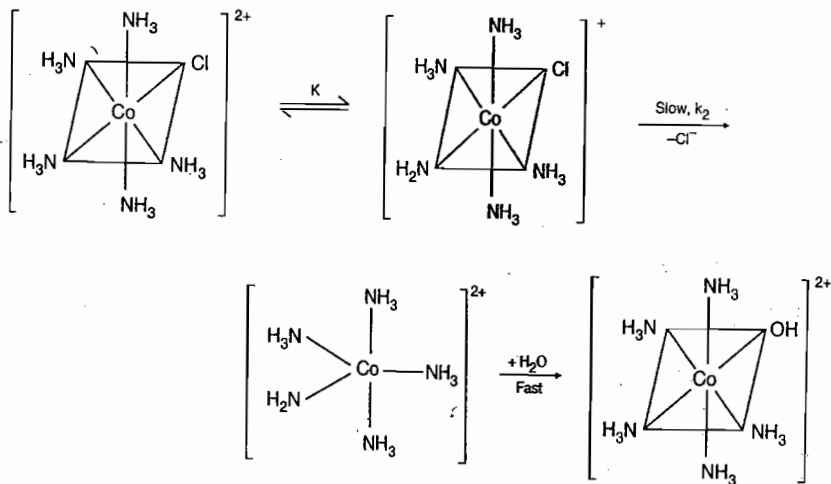

Figure 7.9

The formation of $\text{Co}-\text{N} \pi$ -bond increases the electron density on cobalt which in turn repels the labile ligand, Cl^- and the π -bond also stabilizes the five coordinate intermediate. The donor π -bonding is a strong evidence of an SN^1CB mechanism. Since the dissociation step which is the rate determining step uses the conjugate base of the original complex, therefore, it is called as SN^1CB mechanism.

It has been suggested that, the hydroxide ion abstract proton from the NH_3 group which is *trans* to the leaving group, *i.e.*, the halo group.



Now from acid base equilibrium (i),

$$K = \frac{[\text{CB}][\text{H}_2\text{O}]}{[\text{Co}(\text{NH}_3)_5\text{Cl}]^{2+}[\text{OH}^-]}$$

where K is the equilibrium constant for acid-base equilibrium (i),

$$[\text{CB}] = \frac{K[\text{Co}(\text{NH}_3)_5\text{Cl}]^{2+}[\text{OH}^-]}{[\text{H}_2\text{O}]}$$

Now for rate determining step (ii),

$$\text{Rate} = k[\text{CB}]$$

\therefore

$$\text{Rate} = \frac{kK[\text{Co}(\text{NH}_3)_5\text{Cl}]^{2+}[\text{OH}^-]}{[\text{H}_2\text{O}]}$$

$$\text{Rate} = k_b[\text{Co}(\text{NH}_3)_5\text{Cl}]^{2+}[\text{OH}^-]$$

where k_b is the rate constant for dissociation of conjugate base in rate determining step and

$$k_b = \frac{kK}{[\text{H}_2\text{O}]}$$

The rate determining step is dissociation of conjugate base [reaction (ii)] but since its concentration depends on the OH^- ion concentration through equilibrium and the reaction rate is proportional to OH^- ion concentration.

Base hydrolysis proceeds by SN^1 mechanism but it is consistent with second order: First order with respect to the complex and first order with respect to the base.

Only OH^- ions affect the rate of hydrolysis and the other bases are ineffective as such. The acid-base equilibrium [reaction (i)] is established more rapidly than the over all reaction.

In base hydrolysis of $\text{Co}(\text{III})$ complexes containing amine ligands, the five coordinate intermediate may be either square pyramidal or trigonal bipyramidal. If a square planar intermediate is formed, then there is no movement of ligands after removal of Cl^- from the conjugate base. Therefore, under normal conditions (*i.e.*, in the absence of π -donor ligand), the square pyramidal intermediate is more stable than TBP intermediate.

On the other hand, in trigonal bipyramidal intermediate there is movement of some ligands which requires some amount of energy. Thus, under normal condition (*i.e.*, in the absence of π -bonding) TBP intermediate is less stable. But in the amido complex of $\text{Co}(\text{III})$ (*i.e.*, in conjugate base) the ligands such as $-\text{NH}_2$ or RNH^- are coordinated to $\text{Co}(\text{III})$ and these ligands are π -donor. These π -donor ligands form π -bonds with $\text{Co}(\text{III})$ ion and the TBP intermediate becomes more stable than the square pyramidal intermediate because some energy is released in π -bonding which is greater than the energy required to form TBP intermediate. Thus, base hydrolysis of $\text{Co}(\text{III})$ complexes containing amine ligands is expected to proceed by SN^1CB mechanism through TBP intermediate.

For base hydrolysis it is essential that there should be at least one ligand in a complex which have acidic protons. The reaction proceeds by SN^1CB mechanism involving a TBP intermediate. Water, rather than OH^- , is the entering group.

Chelation and the steric hindrance increase the rate of base hydrolysis. The rate of base hydrolysis is high for diamines. It suggests that reaction proceeds by dissociative mechanism.

Now let us consider rates of base hydrolysis of $[\text{Co}(\text{en})_2\text{LCl}]^+$ complex ions where $\text{L} = \text{Cl}^-$, OH^- , NO_2^- , CN^- etc.

The rate of base hydrolysis of $[\text{Co}(\text{en})_2\text{Cl}_2]^+$ is faster whereas the rate of base hydrolysis of $[\text{Co}(\text{en})_2(\text{NO}_2)\text{Cl}]^+$ and $[\text{Co}(\text{en})_2(\text{CN})\text{Cl}]^+$ is slower than expected. The low reactivity of $[\text{Co}(\text{en})_2(\text{NO}_2)\text{Cl}]^+$ and $[\text{Co}(\text{en})_2(\text{CN})\text{Cl}]^+$ complexes to base hydrolysis in spite of relatively larger value of K_a , can be explained on the basis of π -bonding effect which is shown below :

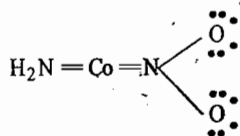

The electronic charge that the amido group provides to the cobalt atom is removed by nitro group due to $\text{M} \rightarrow \text{N} \pi$ -bonding. Thus, it reduces the tendency of labile group to dissociate. The ligand CN^- behaves similar to NO_2^- but to a lesser extent. The halide ions do not undergo such π -bonding and thus are easily activated.

The rate of hydrolysis of $[\text{Co}(\text{py})_4\text{Cl}_2]^+$ or $[\text{Co}(\text{CN})_5\text{Cl}]^{3-}$ is independent of OH^- concentration because there is not protonic hydrogen in the two complexes.

Let us consider the base hydrolysis of the $[\text{Co}(\text{tren})(\text{NH}_3)\text{Cl}]^{2+}$ complex ion. The rate of base hydrolysis depends upon deprotonation of the amino group *trans* to the leaving group. In other words, we can say that the proton of the amino group *trans* to the leaving group play an important role in the rate of base hydrolysis. The $[\text{Co}(\text{tren})(\text{NH}_3)\text{Cl}]^{2+}$ ion exists in two isomeric forms having the red and the purple colours. In the red isomer, the leaving group Cl^- is *trans* to the $-\text{NH}_2$ group [Fig. 7.10(a)] and in the purple isomer the leaving group (i.e., the halo group) is *trans* to the amino group which have no proton [Fig. 7.10(b)].

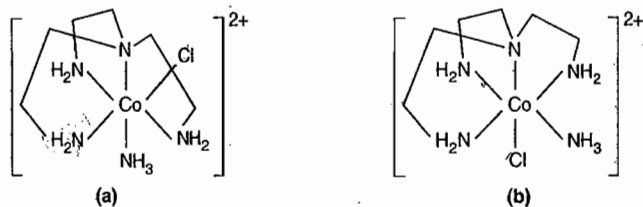

Fig. 7.10 (a) Red isomer, (b) Purple isomer.

The red isomer of $[\text{Co}(\text{tren})(\text{NH}_3)\text{Cl}]^{2+}$ ion is hydrolyzed much more faster than the purple isomer. The red isomer has a removable proton on the nitrogen atom *trans* to the leaving group. The deprotonation of amino group by OH^- ion leads to the formation of a trigonal bipyramidal intermediate in the dissociative (D) or interchange dissociative (I_d) mechanism. The ligand tren stabilizes the TBP

intermediate by ligand's amido group to metal π -interaction between the NH^- group lone pair and an appropriate metal orbital.

Therefore, rate of base catalyzed hydrolysis of red isomer of $[\text{Co}(\text{tren})(\text{NH}_3)\text{Cl}]^{2+}$ is much faster. The base catalysed hydrolysis of red isomer of $[\text{Co}(\text{tren})(\text{NH}_3)\text{Cl}]^{2+}$ [Figure 7.11(a)] leads to attack of hydroxide ion along any of three equatorial edges of TBP intermediate and forms only one product [Figure 7.11(b)]. Thus hydrolysis of the red isomer of $[\text{Co}(\text{tren})(\text{NH}_3)\text{Cl}]^{2+}$ leads to complete retention of configuration.

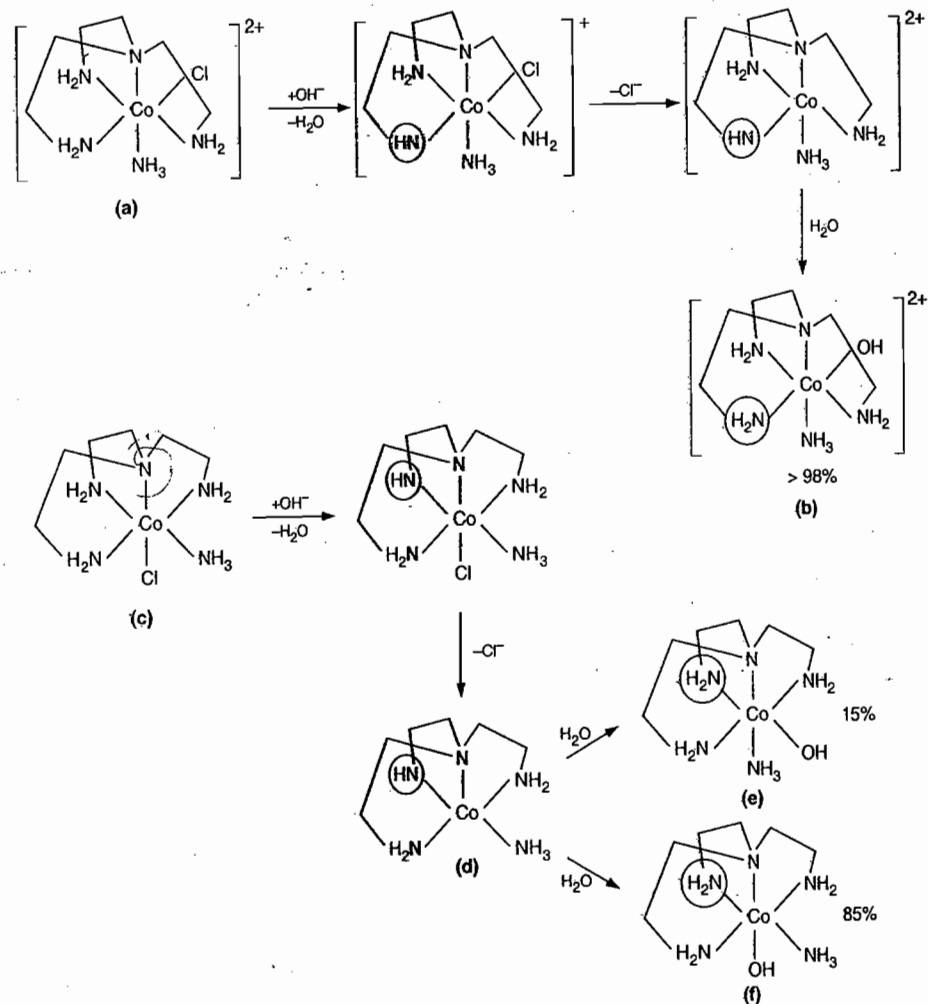
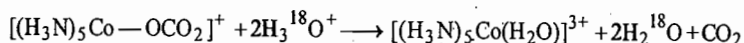

Fig. 7.11

On the other hand, the purple isomer of $[\text{Co}(\text{tren})(\text{NH}_3)\text{Cl}]^{2+}$ [Figure 7.11(c)] ion gives two products, the major product (85%) is same as that obtained by the hydrolysis of the red isomer, the other product is only 15%. This reaction occurs through squarepyramidal (SP) intermediate [Figure 7.11(d)] which is unstable. Some of this is trapped and gives only 15% [Figure 7.11(e)] yield and the majority rearranges to give the major product 85% [Figure 7.11(f)] which is given by the red isomer. The major product is obtained, when the hydroxide ion attacks from the site of the leaving group and the minor product is obtained, when the hydroxide ion attacks in the plane.

Substitution Reactions without Breaking of Metal-ligand Bond

There are some reactions where ligand exchange takes place without cleavage of the metal-ligand bond instead bonds within the ligands themselves are broken and reformed. For example, in acid solution, aminocarbonate complex of Co(III) like $[\text{Co}(\text{NH}_3)_5(\text{CO}_3)]^+$ are converted to the corresponding aqua complex $[\text{Co}(\text{NH}_3)_5(\text{H}_2\text{O})]^{3+}$ with release of CO_2 . When the reaction is carried out in the presence of ^{18}O -labeled water in acidic medium ($\text{H}_3^{18}\text{O}^+$), it is observed that no labeled ^{18}O goes into the resulting aqua complex. Hence the Co—O bond must be retained during the course of reaction.



Mechanism :

The most suitable mechanism for this reaction involves proton attack on the oxygen atom bonded to cobalt atom and CO_2 is then removed by the cleavage of O—C bond.

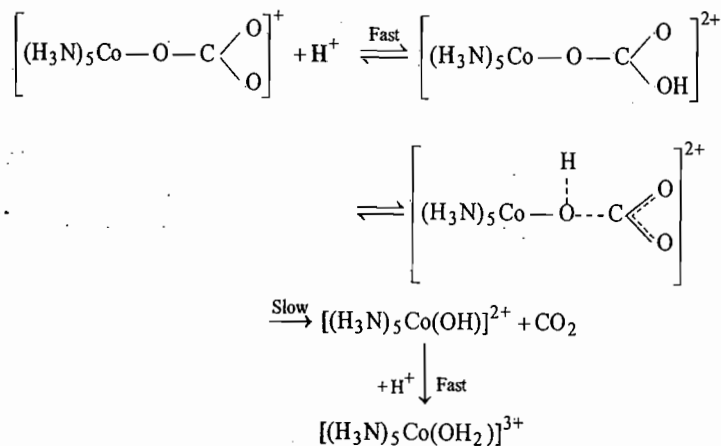

Thus, this reaction is a decarboxylation rather than an acid hydrolysis reaction.

Similar mechanism have been made for $[\text{Co}(\text{NH}_3)_4\text{CO}_3]^+$ complex. In acidic medium $[\text{Co}(\text{NH}_3)_4\text{CO}_3]^+$ having CO_3^{2-} as bidentate ligand is converted to *cis*- $[\text{Co}(\text{NH}_3)_4(\text{H}_2\text{O})_2]^{3+}$. In ^{18}O labeled water (H_2^{18}O), half the oxygens in the product are derived from the solvent.

The first step involves the cleavage of chelate ring (*i.e.*, Co—O bond) and one H_2O molecule from solvent enters into the coordination sphere. The second step like that of $[\text{Co}(\text{NH}_3)_5(\text{CO}_3)]$ involves the removal of CO_2 with cleavage of the O—C bond but without cleavage of the Co—O bond.

Now consider another reaction of formation of a nitrito complex $[(\text{H}_3\text{N})_5\text{Co}(\text{ONO})]^{2+}$ from its corresponding aqua complex, $[(\text{H}_3\text{N})_5\text{Co}(\text{OH}_2)]^{3+}$ which takes place without the breaking of metal-ligand bond.

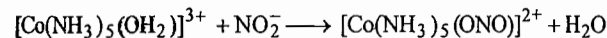

This reaction is very rapid which in itself suggests that the Co—O bond is not broken and can be confirmed by using labeled ^{18}O in aqua complex.

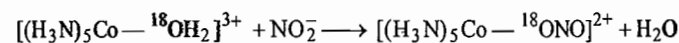

Mechanism :

In weakly acidic solution, the nitrosating agent is N_2O_3 which attacks the unshared pair of electrons on the amine nitrogen by splitting into NO^+ and NO_2^- . N_2O_3 is obtained by dissociation of HNO_2 .

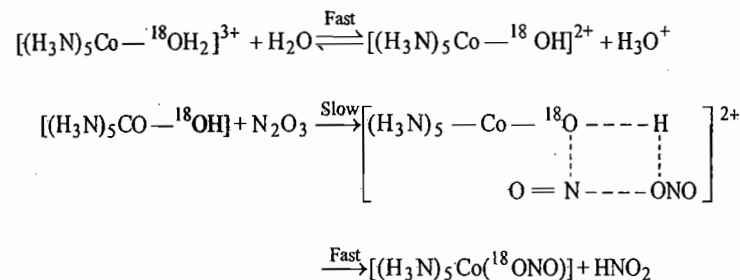
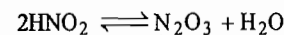

In the transition state, it is the O—H bond which is broken but not a Co—O bond. Thus, oxygen of the H_2O ligand is retained in the nitrito ligand.

STEREOCHEMISTRY OF ACID CATALYZED SUBSTITUTION REACTIONS

It has already been discussed that most substitution reactions in octahedral complexes proceed by dissociative (D) or interchange dissociative (I_d) mechanism through 5-coordinated species either square pyramidal (SP) or trigonal bipyramidal (TBP) intermediate (Figure 7.12).

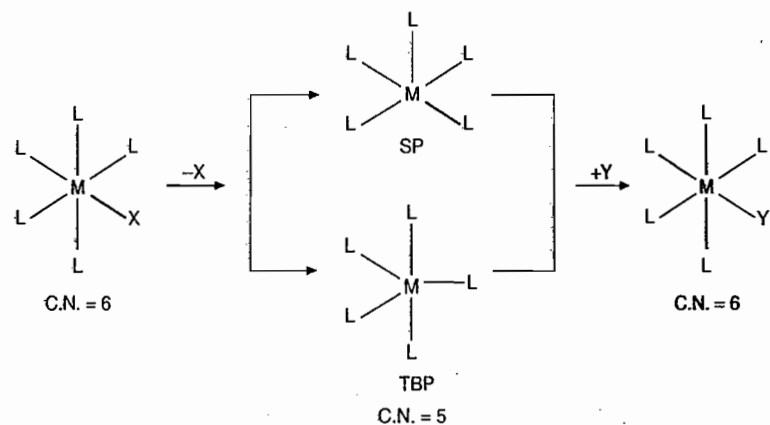

Figure 7.12

Let us consider the substitution reactions of *cis*- and *trans*-isomers of $[\text{Co}(\text{en})_2\text{ClY}]^{2+}$ with H_2O .

The substitution reaction in *cis*- $[\text{Co}(\text{en})_2\text{ClY}]^{2+}$ with H_2O proceeds through 5-coordinate squarepyramidal intermediate $[\text{Co}(\text{en})_2\text{Y}]^{3+}$ to give *cis*- $[\text{Co}(\text{en})_2\text{Y}(\text{H}_2\text{O})]^{2+}$ because the squarepyramidal intermediate has a single site for attack by H_2O . [Figure 7.13] Thus, hydrolysis of *cis*- $[\text{Co}(\text{en})_2\text{ClY}]^{2+}$ type complex ion leads to complete retention of configuration.

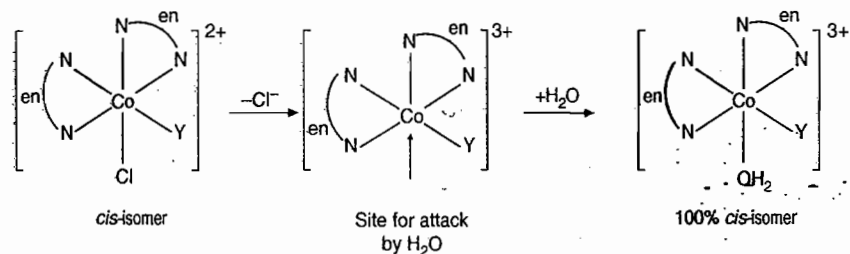

Figure 7.13

The substitution reaction of Cl^- in *trans*- $[\text{Co}(\text{en})_2\text{ClY}]^{2+}$ by H_2O proceeds through 5-coordinate trigonal bipyramidal intermediate to give mixture of *cis*- and *trans*-isomers of $[\text{Co}(\text{en})_2\text{Y}(\text{H}_2\text{O})]^{3+}$ [Figure 7.14] because H_2O molecule can attack the trigonal bipyramidal intermediate at all of the three sites in the equatorial plane. If Y is a good π -donor, then it forms π -bond with metal cation and stabilizes the TBP intermediate. In this case the substitution occurs definitely through TBP intermediate.

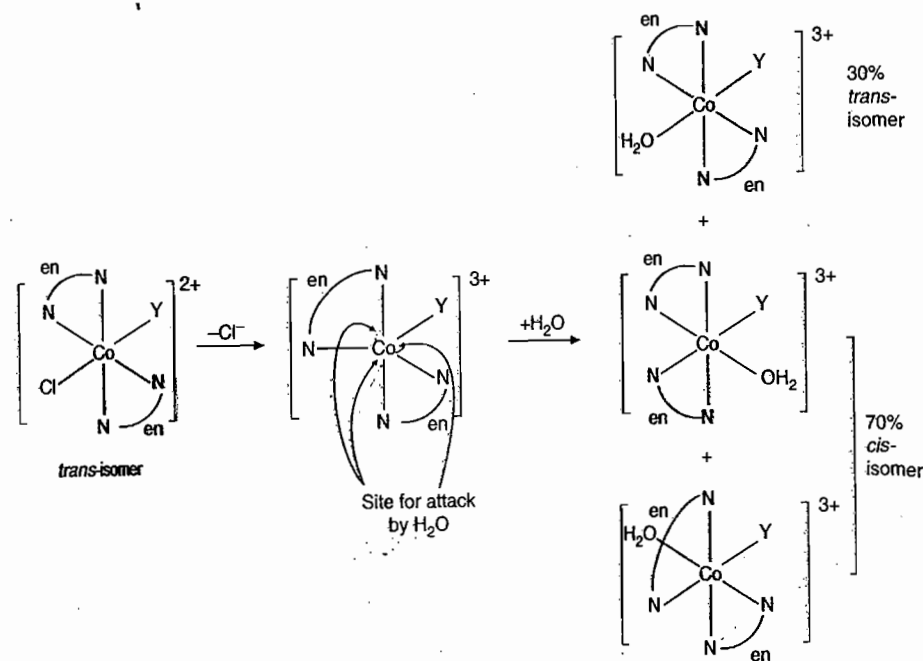

Figure 7.14

In general, *trans*-complexes of the type $[\text{Co}(\text{en})_2\text{ClY}]^{2+}$ undergo stereochemical change upon hydrolysis whereas *cis*-complexes of the type $[\text{Co}(\text{en})_2\text{ClY}]^{2+}$ undergo hydrolysis with retention of the configuration.

In general, *cis*-isomers react more faster than the *trans*-isomers. The ligand Y (*trans* to the leaving group) that leads to stereochemical change in *trans*-isomers are that with lone pairs of $p\pi$ -electrons. These $p\pi$ -electrons interact through ligand to metal π -bonding with an empty metal orbital and stabilizes the TBP intermediate (Fig. 7.15).

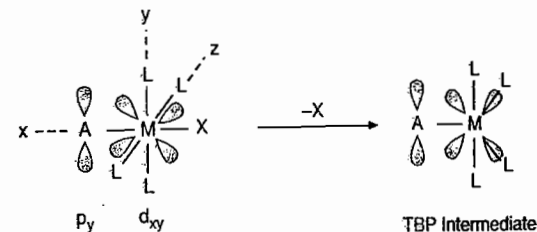

Fig. 7.15

Therefore, the π -donor ligands such as Cl^- , Br^- , I^- , N-bonded NCS^- , NH_2^- etc stabilize the TBP intermediate and favour the stereochemical change.

On the other hand, the substitution reaction in *cis*-isomer $[\text{CoL}_4\text{YX}]^{n+}$ with H_2O proceeds through a five-coordinate squarepyramidal intermediate $[\text{CoL}_4\text{Y}]^{(n+1)+}$ and the $p\pi$ -lone pairs of electrons on the Y -ligand stabilize the squarepyramidal intermediate by interaction with the metal p -orbital previously reoccupied with σ -bonding to the leaving group without rearrangement and the reaction will be more faster since there is no need for rearrangement.

SUBSTITUTION REACTIONS IN SQUARE PLANAR COMPLEXES

The greatest number of square planar complexes usually occur with transition metal ions of d^8 electronic configuration. These include complexes of Ni(II), Pd(II), Pt(II), Rh(I), Ir(I) and Au(III). Square planar complexes of Pt(II) have been extensively studied and analysed because: (i) square planar complexes of Pt(II) are most stable, (ii) easy to synthesised, (iii) Pt(II) complexes of C.N. 4 are always square planar unlike Ni(II) complexes which form tetrahedral complexes with weak ligands and square planar complexes with strong ligands, (iv) substitution reactions in Pt(II) complexes undergo at slow rates and are, therefore, convenient for laboratory study.

Ligand substitution reactions in Ni(II) and Pd(II) square planar complexes undergo 10^6 and 10^7 times more rapidly than Pt(II) complexes respectively.

As we have discussed earlier that the substitution reactions in octahedral complexes proceed by dissociative (SN^1) mechanism but the square planar complexes undergo substitution reactions by associative (SN^2) mechanism. When square planar complexes of Pt(II) undergo substitution reactions there is retention of configuration *i.e.*, *cis*-isomer gives *cis* product and *trans*-isomer gives *trans* product. This observation suggests that Pt(II) square planar complexes do not undergo substitution reactions by dissociative mechanism.

Factors Affecting Rates of Substitution Reactions in Square Planar Complexes of Pt(II)

Several factors that affect the reactivity of square planar complexes are:

- | | |
|-------------------------------|---|
| (1) Nature of Entering Ligand | (2) Nature of Leaving Group |
| (3) Charge Effect | (4) Steric Effect of Non-leaving Ligand |
| (5) Solvent Effect | (6) <i>Trans</i> Effect |

(1) **Nature of Entering Ligand**: We know that the equilibrium constant of substitution reactions can be used to rank ligands in order of their basicity (*i.e.*, strength as Lewis base). Thus, basicity is a thermodynamic property and it is measured in terms of pK_a of conjugate acid of a Lewis base.

Rates of reactions that proceed by an associative mechanism is strongly dependent on the nucleophilicity of the entering group or ligand. Nucleophilicity of an entering ligand is the measure of its relative rate of attack on a complex in nucleophilic substitution reactions. It implies that nucleophilicity is a kinetic term. The nucleophilicity is parallel but not necessarily equivalent to basicity *i.e.*, nucleophilic character of the reagents does not correlate their basicity. Basicity is of less importance but polarizability plays an important role in determining the reactivity of the ligand. Further, the polarizability of a ligand is always more important for rates than for equilibria. Now according to SHAB principle, soft (polarizable) ligands are more effective towards soft substrates (*i.e.*, complexes) and particularly hard ligands like OH^- are more effective towards hard substrates.

For Pt(II) square planar complexes, since Pt(II) is a soft substrate, thus more polarizable ligands are good nucleophiles.

Increasing order of nucleophilicities of some ligands for P(II) square planar complexes is:

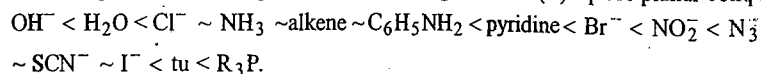

Finally more is the nucleophilicity of an entering ligand higher will be the rate of substitution reaction by associative mechanism and *vice-versa*.

(2) **Nature of Leaving Group**: The effect of leaving group has been studied in the following reaction:

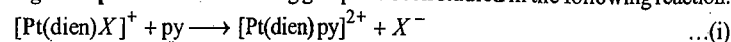

In complex $[\text{Pt}(\text{dien})\text{X}]^+$, the three coordination position are occupied by the inert ligand, dien and entering ligand is always pyridine (py). The variable in the above reaction is only X^- (*i.e.*, the leaving ligand). As X^- ligand is changed, the rate of reaction is also changed. The value of rate constants for various leaving ligands in the reaction (i) are given in the Table 7.3.

Table 7.3 : Rate Constants for the Reaction (i)

Ligand-X	$10^6 \times \text{Rate Constant (s}^{-1}\text{)}$
NO_3^-	Very fast
H_2O	1900
Cl^-	35
Br^-	23
I^-	10
N_3^-	0.80
SCN^-	0.30
NO_2^-	0.05
CN^-	0.02

The observed rate constants for various leaving ligands suggest the following order of rate of reaction:

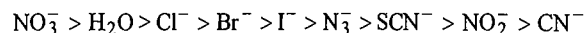

This order of rate of reaction indicates that the leaving group has significant effect on the rate of reaction. It also indicates that considerable Pt-X bond breaking is involved in forming the transition state and it is observed that Pt-X bond breaking make a contribution comparable to that of the formation of Pt-py bond.

(3) **Charge Effect**: Martin-*etal* has been studied the hydrolysis of the series of complexes $[\text{PtCl}_4]^{2-}$, $[\text{Pt}(\text{NH}_3)\text{Cl}_3]^-$, $[\text{Pt}(\text{NH}_3)_2\text{Cl}_2]$ and $[\text{Pt}(\text{NH}_3)_3\text{Cl}]^+$ with charge varying from -2 to +1 (*i.e.*, 3 unit change in charge on complex). It was observed that rates of hydrolysis of these four complexes are approximately same (vary only by a factor of two). There is a large difference in charges but there is a remarkable small variation in the rates. The Pt-Cl bond breaking should be more difficult in complexes

with higher positive charge and also, in the complexes with higher positive charge, the ligand approaches easily. The discussion indicates that Pt—Cl bond breaking and Pt—OH₂ bond making both are of equal importance and the reaction proceed by associative (A) or interchange associative (I_a) mechanism.

(4) **Steric Effect of Non-leaving Ligands** : The octahedral complexes are closed to nucleophilic attack and whereas square planar complexes are open to nucleophilic attack. Thus, octahedral complexes undergo substitution reactions by dissociation mechanism and the square planar complexes undergo substitution reactions by associative (S_N²) mechanism. If steric hindrance increases, the rate of substitution in octahedral complexes increases because steric hindrance favours the dissociation. Bulky groups block the approach of attacking ligand. The dissociative reaction reduces the coordination number and the overcrowding decreases.

In square planar complexes, since the substitution reaction proceeds by associative mechanism, therefore, steric hindrance decreases the rate of reaction because the overcrowding opposes the increasing of coordination number (i.e., formation of intermate or transition state of C.N.5).

The rate constants observed for hydrolyses of *cis* and *trans*-[Pt(PEt₃)₂Cl] are shown below :

	L = Pyridine	2-methyl pyridine	2,6-dimethyl pyridine
For <i>cis</i>	Rate constants (s ⁻¹) 8 × 10 ⁻²	2.0 × 10 ⁻⁴	1.0 × 10 ⁻⁶
For <i>trans</i>	1.2 × 10 ⁻⁴	1.7 × 10 ⁻⁵	3.4 × 10 ⁻⁶

In *cis* complex, when L is pyridine there is less crowding and rate of hydrolysis is faster. When L is 2-methylpyridine i.e., the methyl group is adjacent of N-donor atom, it increases the crowding and hence decreases the rate. In 2-methyl pyridine complex, the methyl group are either above or below the plane and thus shields the Pt(II) either above or below the square plane. In 2,6-dimethylpyridine complex, crowding further increases near the N-donor atom and hence again the rate decreases. The methyl groups block the positions above and below the plane. The effect of steric hindrance is smaller if L is *trans* to Cl⁻.

(5) **Solvent Effect** : It has been observed that the solvent path for square planar substitution involves direct replacement of X⁻ by the solvent. If there is an increase in coordination ability of the solvent with metal cation, then the contribution made by this path to the overall rate of reaction would also increase. This is in accordance with the experimental results of the solvent effect on the rate of ³⁶Cl⁻ exchange with *trans*-[Pt(py)₂Cl₂] complex. Effect of solvent on the rate of ³⁶Cl⁻ exchange with *trans*-[Pt(py)₂Cl₂] is given in Table 7.4

Under the experimental conditions, viz. moderately low concentration of ³⁶Cl⁻, the solvents are divided into two categories :

(i) The good coordinating solvents like DMSO, H₂O, ROH etc which provide almost entirely a solvent path for exchange [*k_s* >> *k_{Cl}*(Cl⁻)] For these solvents, the rate of exchange is independent of [Cl⁻]. For good solvent, the value of *K_{obs}* increases in the order : ROH < H₂O ~ CH₃NO₂ < DMSO. The rate of exchange is faster in DMSO than in water.

Table 7.4

Solvent in Which Rate is Independent of [Cl ⁻]	<i>k_{obs}</i> (s ⁻¹)	Solvent in Which Rate is Dependent on Cl ⁻	<i>k</i> (M ⁻¹ s ⁻¹)
DMSO	3.8 × 10 ⁷	CCl ₄	10 ⁴
H ₂ O	3.5 × 10 ⁵	C ₆ H ₆	10 ²
CH ₃ NO ₂	3.2 × 10 ⁵	<i>t</i> -C ₄ H ₉ OH	10 ⁻¹
C ₂ H ₅ OH	1.4 × 10 ⁵		

(ii) The poor coordinating ligands such as CCl₄, C₆H₆, sterically hindered alcohols etc which contribute little to the overall rate of reaction. For these solvents, the rate of exchange depends on the concentration of Cl⁻.

(6) **Trans Effect** : Ligands other than the entering and leaving groups may affect the rate of substitution reaction. A ligand which is not lost in the reaction is called a spectator ligand.

The effect of a spectator ligand coordinated to metal cation upon the rate of substitution of ligands *trans* to it is called *trans* effect.

Chatt-*et-al* have suggested that the *trans* effect of a spectator ligand or group attached to a metal cation is the tendency of that group to direct an incoming group to occupy the position *trans* to that group.

The spectator ligand or group which directs an incoming ligand to occupy the position *trans* to it is called a *trans* directing group or *trans* director.

Now consider the substitution reactions in square planar complex, *trans* MLX₃ in which L is a spectator (or non-leaving) group and X *trans* to L is a leaving group.

If the ligand X *trans* to ligand L is replaced rapidly by another ligand Y to give MLX₂Y, then L is said to have large labilizing effect or *trans* labile effect. Since the ligand L makes the ligand X labile *trans* to it so the *trans* effect is also called as labilizing effect.

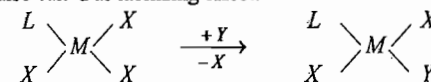

The labilizing effect or *trans* effect of some ligands follow the order :

(High end) CN⁻, CO, NO, C₂H₄ > PR₃, AsR₃, H⁻ > CH₃⁻, SC(NH₂)₂ > C₆H₅⁻, NO₂⁻, I⁻, ...

SCN⁻ > Br⁻ > Cl⁻ > py > RNH₂, NH₃ > F⁻ > OH⁻ > H₂O (low end)

The series given above is called *trans* directing series.

The ligands like CN⁻, CO, NO, C₂H₄ etc. lying on the high end are π-acceptors and are strong *trans* directors. On the other hand, the ligands like OH⁻, H₂O lying on weak end are very poor *trans* directors.

A strong *trans* director has the ability to promotes more rapid substitution of the ligand *trans* to it self than it does of the ligand *cis* to itself.

The *trans* effect is a kinetic phenomenon because *trans* effect of a ligand L promotes the rapid substitution of ligand (X) *trans* to itself.

The *trans* effect (i.e., kinetic *trans* effect) is differentiated from *trans* influence. The *trans* influence is a thermodynamic phenomenon, i.e., ligands can influence the ground state properties of ligands to which they are *trans* such as the *trans* M-L bond distance or the vibrational frequency. For example : A

Good *trans*-directing ligand weakens the bond between the metal and the *trans* ligand. The *trans* influence is shown in the following complexes:

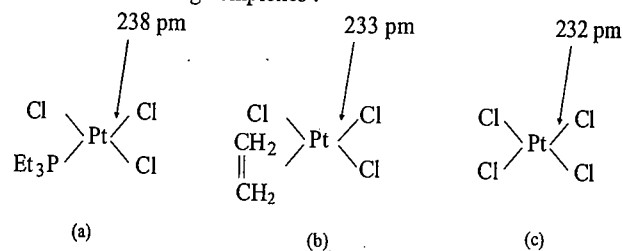

From the complexes (a), (b) and (c) it is observed that the order of *trans* influence of *trans* ligands is:
 $\text{Et}_3\text{P} > \text{CH}_2 = \text{CH}_2 > \text{Cl}^-$

Applications of *Trans* Effect

Most of the work on *trans* effect has been done on square planar complexes of Pt(II).

The *trans* effect is very useful in the synthesis of large number of square planar complexes of Pt(II).

1. Synthesis of *cis*- and *trans*- $[\text{Pt}(\text{NH}_3)_2\text{Cl}_2]^-$:

The synthesis of *cis*- $[\text{Pt}(\text{NH}_3)_2\text{Cl}_2]^-$ is carried out by treatment of the $[\text{PtCl}_4]^{2-}$ ion with ammonia.

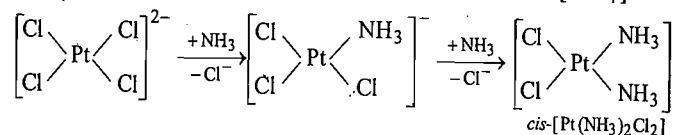

In the second step of this reaction ammonia occupies the *cis* position because the *trans* effect of Cl^- is greater than that of ammonia.

It means that the least reactive Cl^- in $[\text{Pt}(\text{NH}_3)_2\text{Cl}_2]^-$ is *trans* to ammonia.

The synthesis of *trans*- $[\text{Pt}(\text{NH}_3)_2\text{Cl}_2]^-$ is carried out by the treating $[\text{Pt}(\text{NH}_3)_4]^{2+}$ with Cl^- .

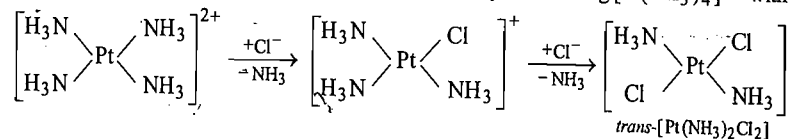

In the above reaction Cl^- replaces most labile NH_3 in $[\text{Pt}(\text{NH}_3)_4]^{2+}$ which is *trans* to Cl^- group and thus results in the formation of *trans*- $[\text{Pt}(\text{NH}_3)_2\text{Cl}_2]^-$.

2. Synthesis of *cis*- and *trans*- $[\text{Pt}(\text{NH}_3)(\text{NO}_2)\text{Cl}_2]^-$ Ion:

The synthesis of *cis*- and *trans*- isomers of $[\text{Pt}(\text{NH}_3)(\text{NO}_2)\text{Cl}_2]^-$ ion is based on *trans* directing ability of Cl^- , NH_3 and NO_2^- groups which is in the order of:

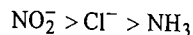

The *cis*-isomer is prepared by the action of NH_3 on $[\text{PtCl}_4]^{2-}$ followed by NO_2^- group.

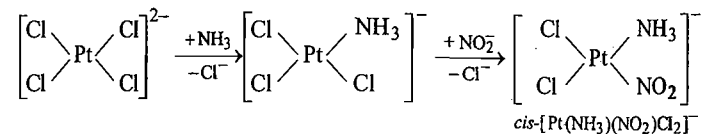

On the other hand, *trans* isomer is obtained by treating $[\text{PtCl}_4]^{2-}$ with NO_2^- followed by NH_3 group.

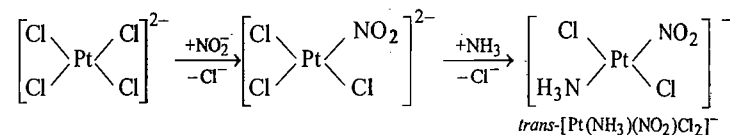

3. Synthesis of *cis*- and *trans*- $[\text{Pt}(\text{C}_2\text{H}_4)(\text{NH}_3)\text{Cl}_2]^-$:

The synthesis of *cis*- and *trans*- isomers of $[\text{Pt}(\text{C}_2\text{H}_4)(\text{NH}_3)\text{Cl}_2]^-$ is based on the *trans* directing ability of C_2H_4 , NH_3 and Cl^- ligands which is in the order of:

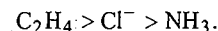

The *cis*-isomer is prepared by treating $[\text{PtCl}_4]^{2-}$ with NH_3 followed by C_2H_4 .

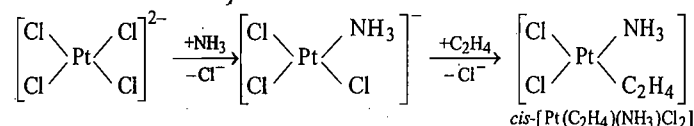

The *trans*-isomer is prepared by treating $[\text{PtCl}_4]^{2-}$ with C_2H_4 followed by NH_3 ligand.

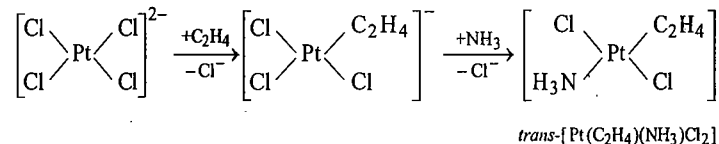

4. Synthesis of *cis*- and *trans*-Isomer of $[\text{Pt}(\text{PR}_3)_2\text{Cl}_2]^-$:

Since *trans* effect of PR_3 is greater than that of Cl^- , therefore, *trans*-isomer is obtained by treating $[\text{PtCl}_4]^{2-}$ with PR_3 as follows:

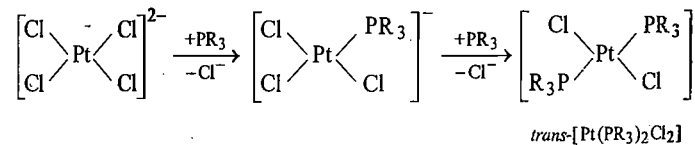

The extent to which a ligand affects the ground state properties such as metal to ligand bond distance, the vibrational frequency and coupling constant *trans* to itself in a complex is called the *trans* influence.

Let us consider the following two types of square planar complexes of Pt(II) to understand this theory :

(i) **PtX₄ Type Complex** : According to this theory the Pt(II) cation induces a dipole in all the four ligands. Since all the four ligands (*i.e.*, ligands *trans* to one another) are same, therefore, the induced dipole of one ligand is cancelled by the dipole of its *trans* ligand and thus the resultant dipole is zero. (Figure 7.16). Hence none of the four ligands show *trans* effect.

(ii) **[PtLX₃] Type Complex** : The primary charge on Pt(II) ion induces a dipole in all the four ligands. The dipole in two X ligands which are similar and *trans* to each other balance each other. Thus, any of these two ligands do not show *trans* effect. On the other hand, the two ligands L and X which are *trans* to each other do not because L is larger and has greater polarizability than X. The net result is that the primary charge on Pt(II) ion induces a dipole in L which in turn induces a dipole in Pt(II). In other words, we can say that Pt(II) and L both become polarized or distorted [Figure 7.17(a)]. The orientation of this polarization (or dipole) is such that the positive charge at the point of Pt(II) *trans* to L is reduced and the negative charge at the point of Pt(II) *trans* to L [Figure 7.17(b)]. Thus, this negative charge repels the ligand X. Hence the attraction of X for Pt(II) is reduced and the Pt—X bond *trans* to L is lengthened and weakened. The Pt—X bond *trans* to L becomes longer and longer than Pt—X bond *cis* to L (Figure 7.21) because there is no polarization in two X ligands which are *trans* to one another. The weakening of Pt—X bond *trans* to L enhances the replacement of X *trans* to L by the incoming ligand. The ligand L which has the greater polarizability also has the greater *trans* effect.

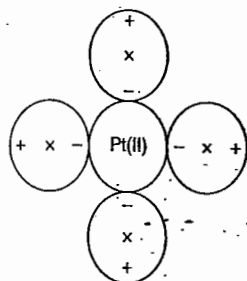

Figure 7.16

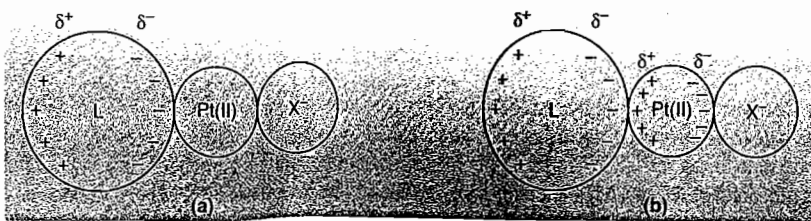

Figure 7.17 (a) Pt(II) ion induces a dipole in polarizable *trans* ligand L
(b) The induced dipole in ligand L induces a dipole in polarizable Pt(II) ion.

(2) The π -bonding Theory

The electrostatic polarization theory has explained the *trans* effect of the ligands which are σ -donor and lie at the low end of the *trans* effect series like Cl^- , Br^- , I^- , OH^- , H_2O , NH_3 etc. But this theory could not explain the *trans* effect of ligands which are π -acceptors and lie at the high end of *trans* effect series like CO , CN^- , C_2H_4 , NO , PR_3 etc. The high *trans* effect of π -acceptor ligands can be explained on the basis of π -bonding theory.

According to this theory the vacant π or π^* orbitals of the π -acceptor ligand (L) accepts a pair of electrons from the filled d -orbitals (d_{xz} or d_{yz}) of the metal to form the M-L π -bond ($d\pi-p\pi$ or $d\pi-d\pi$ or $d\pi-d\pi^*$ bond) and also stabilizes the transition state or intermediate.

Let us discuss the *trans* effect in *trans*-[PtA₂LX] (where L is the π -bonding ligand). In *trans*-[PtA₂LX] complex an olefin (C_2H_4) forms a σ -bond by donation of its π -electron density to platinum, the ligands CO , CN^- form σ -bond by donation of a pair of non-bonding electrons from carbon to platinum and R_3P forms σ -bond by donation of a pair of electrons from phosphorus to platinum.

When the ligand like (CO , CN^- , C_2H_4) forms a π -bond, there is donation of electron density from a metal orbital of π -symmetry (say d_{yz}) into a ligand (say C_2H_4) orbital of same symmetry, the ligand π^* orbital.

The withdrawal of electron density from platinum increases the electron density towards the ligand L and diminishes in the direction of ligand X. Thus, the Pt—X bond is weakened and entrance of an incoming ligand (Y) becomes easy. This implies that the transition state (trigonal bipyramidal) is stabilized and the rate of substitution reaction is enhanced. This is, of course, the effect of metal to ligand $d\pi-\pi^*$ bonding (Figure 7.20).

If L is CO , then π -bond is formed by donation of electron pair from d -orbitals of Pt(II) to the vacant π^* of CO (Figure 7.18).

If L is R_3P , then π -bond is formed by donation of electron pair from d -orbitals of Pt(II) to the vacant d -orbital of phosphorus (Figure 7.19).

The strong π -acceptor ligand (L) occupies an equatorial position in the trigonal bipyramidal (TBP) intermediate and forces the ligand X to replace to form the square planar product.

The five coordinated trigonal bipyramidal intermediate is stabilized because there is a strong interaction of the filled d -orbitals of Pt(II) with the orbitals of equatorial ligands than with the axial ligands.

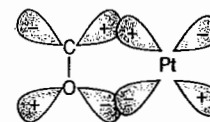

Figure 7.18 Metal to ligand transfer of pair of electrons to form $d\pi-\pi^*$ bond.

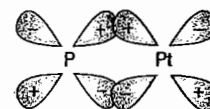

Figure 7.19 Metal to ligand donation of pair of electron to form $d\pi-d\pi$ bond.

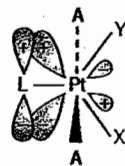

Figure 7.20 Five coordinated trigonal bipyramidal activated complex for the reaction

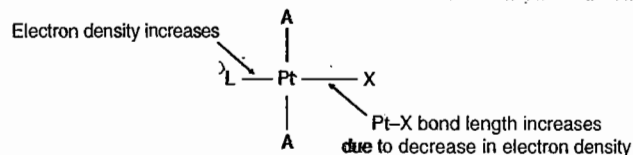

Figure 7.21

The ligands lying on high end in the *trans* effect series are strong π -acceptors, followed by strong σ -donors (*i.e.*, strong polarizable) like SCN^- , I^- etc. The ligands at the low end of the series are neither strong σ -donor nor π -acceptors but these are strong π -donors like H_2O , OH^- , NH_3 etc.

MECHANISM OF SUBSTITUTION REACTIONS IN SQUARE PLANAR COMPLEXES

Substitution reactions in octahedral complexes proceed by the dissociative (*i.e.*, $\text{S}_{\text{N}}1$) mechanism because after dissociation of one group, addition of an incoming group does not change the coordination number *i.e.*, there is no increase in steric hindrance during the dissociative mechanism and the stability of intermediate (C.N. = 5) is greater. If the reaction in octahedral complexes would occur by associative mechanism (*i.e.*, $\text{S}_{\text{N}}2$ mechanism), then there will be increase in coordination number (*i.e.*, increase in steric hindrance) which causes the decrease in stability of the intermediate or activated complex of coordination number 7.

The nucleophilic substitution reactions in square planar complexes proceed through associative (*i.e.*, $\text{S}_{\text{N}}2$) mechanism because there is small steric and electronic repulsions and the incoming ligand attacks on Pt(II) easily to form a stable trigonal bipyramidal intermediate or activated complex. In nucleophilic substitution reactions in square planar complexes of Pt(II) the incoming ligand Y attacks from either side of the plane (*i.e.*, above or below of the plane of molecule) to form a five coordinate intermediate. Further more in the square planar complexes, Pt(II) has a vacant p_z orbital of the relatively low energy which accepts the electron pair donated by the incoming ligand and a square pyramidal species is formed (Figure 7.22) which in turn undergoes a transformation to a trigonal bipyramidal intermediate.

The TBP species that forms during the reaction and then rearranges to give product may exist either as an intermediate or an activated complex. In TBP species the ligands L, X and Y lie on its equatorial positions and the two ligands A lie on its axial positions (Figure 7.22).

As X moves from trigonal plane, the L-Pt-Y angle opens and the geometry is passed through a square pyramid to form the square planar product.

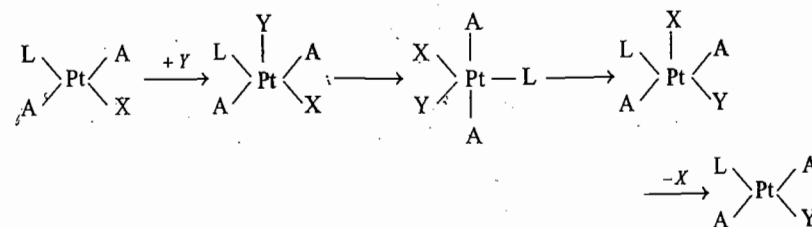
Figure 7.22 Mechanism of nucleophilic substitution reaction in square planar $[\text{PtA}_2\text{LX}]$ complex.

It is observed that *cis*- $[\text{PtA}_2\text{LX}]$ gives *cis*-product and *trans*- $[\text{PtA}_2\text{LX}]$ gives *trans*-product, *i.e.*, these reactions are entirely stereospecific. This stereospecificity supports the reactions to proceed by associative mechanism (Figure 7.23).

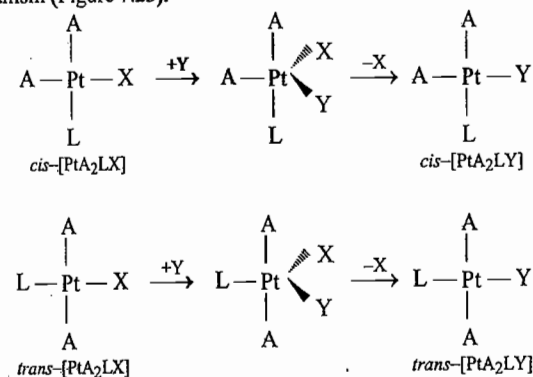
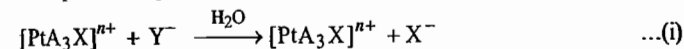

Figure 7.23 Stereochemistry of square planar substitution through TBP intermediate.

The mechanism of substitution reactions of square planar complex $[\text{PtA}_3\text{X}]^{n+}$ with Y^- in aqueous solution to give $[\text{PtA}_3\text{Y}]^{n+}$ is often complicated by the occurrence of alternative pathways because solvent water itself behaves as a potential ligand. If the following reaction :



is first order in complex and independent of the concentration of Y^- then the rate of reaction will be equal to $k_1[\text{PtA}_3\text{X}^{n+}]$ and if there is an alternative pathway in which the rate law is overall second order, first order in complex and first order in Y^- , then the rate of reaction will be $k_2[\text{PtA}_3\text{X}^{n+}][\text{Y}^-]$. If both reaction pathways occur simultaneously at comparable rates, the rate law will be given by the expression :

$$\begin{aligned} \text{Rate} &= k_1[\text{PtA}_3\text{X}^{n+}] + k_2[\text{PtA}_3\text{X}^{n+}][\text{Y}^-] \\ &= [k_1 + k_2(\text{Y}^-)][\text{PtA}_3\text{X}^{n+}] \end{aligned}$$

where k_1 and k_2 are the first order and second order rate constants respectively. Experimental evidences indicate that this type of reactions are pseudo first order, when Y^- is in large excess. Thus, the observed pseudo first order rate constant is related to k_1 and k_2 as :

$$k_{\text{obs}} = k_1 + k_2 [Y^-]$$

Since Y^- is in large excess, therefore, the concentration of Y^- is taken to be constant. Under this condition the observed rate constant, k_{obs} is pseudo first order and is related to k_1 and k_2 as shown by the equation :

$$k_{\text{obs}} = k_1 + k_2 [Y^-] \quad \dots(\text{ii})$$

Equation (ii) indicates that by repeating the reaction at various concentrations of Y^- , the values of both k_1 and k_2 can be obtained because a plot of k_{obs} against $[Y^-]$ gives a straight line with k_1 as the intercept and k_2 as the slope (Figure 7.24).

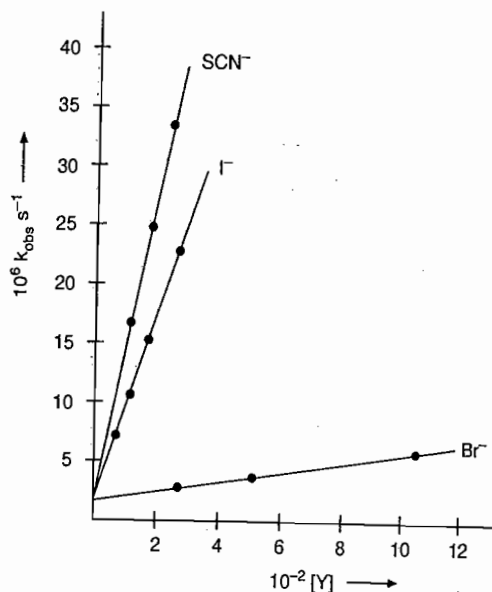

Figure 7.24 Plot of observed rate constants, $k_{\text{obs}} \text{ s}^{-1}$ for the reaction of $\text{trans-}[\text{Pt}(\text{Py}_2)\text{Cl}_2]$ against concentrations of nucleophile $[Y^-]$.

The two paths of the reaction (i) are shown in Figure 7.25.

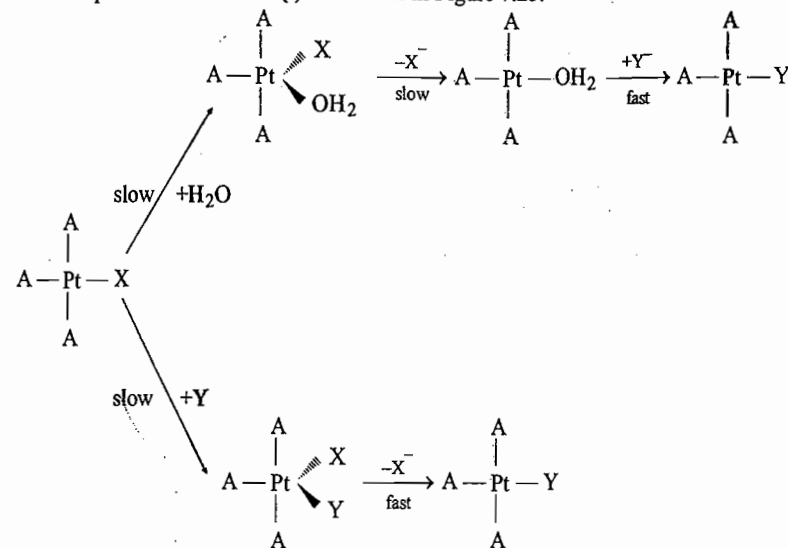

Figure 7.25 Two path mechanism proposed for the reaction



The upper path is the solvent path and the lower one is direct path. In the solvent path the solvent (H_2O) replaces X^- in a slow rate which is subsequently replaced by the reagent Y^- in a rapid step. It has been observed that Y^- independent path is not an $\text{S}_{\text{N}}1$ process but is a direct $\text{S}_{\text{N}}2$ process and is a second order path. On the other hand, the solvent path is a pseudo first order.

The rate constant k_1 is due to slow displacement of X^- by the solvent (H_2O) and k_2 is due to the direct nucleophilic displacement of X^- by Y^- . Thus, it is convenient to represent the solvent path k_1 as k_{S} and the reagent path k_2 as k_{Y} . Therefore, the equation (ii) becomes :

$$k_{\text{obs}} = k_{\text{S}} + k_{\text{Y}} [Y^-] \quad \dots(\text{iii})$$

EVIDENCE IN FAVOUR OF ASSOCIATIVE MECHANISM

Martin and his students have shown that the rates of hydrolysis of the series of complex as $[\text{PtCl}_4]^{2-}$ through $[\text{Pt}(\text{NH}_3)_3\text{Cl}]^+$ are approximately same, although there is a three unit change in charge (*i.e.*, -2 to +1) on the Pt(II) complex.

The breaking of Pt-Cl bond becomes more difficult as the charge on the complexes becomes more positive. But, on the other hand, the formation of new bond (*i.e.*, attraction Pt(II) for incoming ligand) increases in the same order. This suggests that in the transition state both bond making and bond breaking is of comparable importance. Thus, the solvent path k_{S} , like the direct displacement path k_{Y} appears to be associative ($\text{S}_{\text{N}}2$) process.

REDOX REACTIONS OR ELECTRON TRANSFER REACTIONS

In substitution reactions (either in octahedral or square planar complexes) there were some chemical changes but the oxidation states of the metals were the same *i.e.*, there was no electron transfer from one complex to another. Electron transfer reactions of transition metal complexes are the oxidation-reduction (redox) reactions which involve the transfer of an electron from one complex to another. The electron transfer reactions may occur either with or without chemical changes.

The complex which loses electron, the oxidation state of metal increases and it is said to be oxidized and this complex is called reducing agent. On the other hand, the complex which gains electron, the oxidation state of metal decreases and it is said to be reduced and this complex is called the oxidizing agent. An example of an electron transfer reaction is given below:

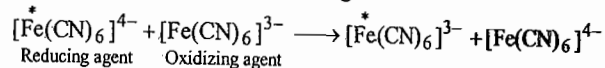

In this reaction $[\text{Fe}(\text{CN})_6]^{4-}$ is oxidized by $[\text{Fe}(\text{CN})_6]^{3-}$ and $[\text{Fe}(\text{CN})_6]^{3-}$ is reduced by $[\text{Fe}(\text{CN})_6]^{4-}$.

The electron transfer reactions involving transition metal complex are believed to occur by the following two mechanisms :

- (I) Outer Sphere Mechanism
- (II) Inner Sphere Mechanism

(I) Outer Sphere Mechanism

In this type of reactions, both complexes participating in the reaction undergo substitution reactions more slowly than the rate of electron transfer. The oxidant and the reductant come as close to each other as possible and the coordination spheres stay intact and transfer of an electron takes place from reductant to oxidant. Thus, an outer sphere mechanism involves electron transfer from reductant to oxidant when the intact coordination spheres are in contact at their outer edges *i.e.*, the distance between two metals is minimum.

An outer sphere electron transfer may occur in the following elementary steps :

In the first step the oxidant and reductant come closer and form a precursor complex

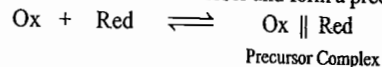

In the second step, there is activation of the precursor complex which includes reorganization of the solvent molecules and changes in M-L bond lengths which occurs before electron transfer. Then, electron transfer takes place.

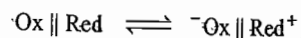

In the final step, the ion pair is dissociated into products

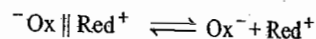

Salient Features of Outer Sphere Mechanism

- (1) Both the reactants (*i.e.*, oxidant and reductant) should be kinetically inert. However, if one of the complexes is labile, then the inert complex should not possess a donor atom which can be used to form the bridge with labile complex.

For example : Reduction of $[\text{Fe}(\text{CN})_6]^{3+}$ by $[\text{Cr}(\text{H}_2\text{O})_6]^{2+}$.

If both the oxidant and the reductant are labile and there is a possibility of electron transfer from π^* of reductant to the π^* of oxidant, then the reaction proceeds through outer sphere mechanism.

For example : $[\text{Fe}(\text{H}_2\text{O})_6]^{2+} + [\text{Fe}(\text{H}_2\text{O})_6]^{3+} \longrightarrow [\text{Fe}(\text{H}_2\text{O})_6]^{3+} + [\text{Fe}(\text{H}_2\text{O})_6]^{2+}$

- (2) When both the reactants are inert with respect to ligand exchange *e.g.*, $[\text{Fe}(\text{CN})_6]^{4-}$ and $[\text{Fe}(\text{CN})_6]^{3-}$, a close approach of the metal ions is impossible and the electron transfer takes place by a tunneling or outer sphere mechanism. The rate of electron transfer depends upon the ability of electrons to tunnel through the ligands.
- (3) The rate constants of electron transfer by outer sphere mechanism are found to vary over a wide range as shown in the Table 7.5 and 7.6.

According to Frank-Condon principle, the electronic transition occur much more rapidly than rearrangement of atoms so that bond distances do not change during very short time of electronic transition.

The electron transfer is very fast when both the complexes are low spin including that the electron transfer takes place from $t_{2g}(\pi^*)$ of reductant to the $t_{2g}(\pi^*)$ of oxidant. The first reason is that energy levels of these two t_{2g} orbitals are same. The t_{2g} orbitals are not shielded from the ligands and the electron transfer from and to is easier and no input energy is required. The second reason is that there is no appreciable change in M-L bond length due to $\pi \rightarrow \pi^*$ electron transfer.

The rates of electron transfer are much faster between the complexes which have π -acceptor ligands (like CN^- , phen, bpy etc) than for complexes of the same metal having purely σ -donor ligands (like H_2O , NH_3 , en etc). The π -acceptor ligands have vacant π^* orbitals that can accept electron being transferred, then pass them on to the receiving metal ion (*i.e.*, oxidant) whereas the σ -donor ligands do not have such tendency. Thus, outer sphere electron transfer is direct electron transfer from one metal to another in case of complexes having π -donor ligands. On the other hand, electron transfer is indirect (*i.e.*, from one metal to ligands to the another metal) if the complexes have π -acceptor ligands.

The electron transfer is slow if electron transfer occurs from e_g (or σ^*) orbital of reductant to e_g (or σ^*) of the oxidant because the e_g orbitals are shielded from the surroundings (*i.e.*, ligands) and the transfer of electron is sterically slow. The $t_{2g} \rightarrow t_{2g}$ electron transfer is faster than $e_g \rightarrow e_g$ transfer.

Electron transfer between high spin and low spin complexes is also slow because electron transfer takes place from e_g or σ^* (called HOMO) of the reductant to vacant e_g or σ^* (called LUMO) of the oxidant resulting in large changes in M-L bond length. This conditions arises between high spin $\text{Co}^{2+} (d^7)$ and low spin $\text{Co}^{3+} (d^6)$ complexes.

- (4) Outer sphere electron transfer reactions between complexes of different metal cations *i.e.*, cross reactions are faster than that of self exchange reactions.
- (5) Electron transfer occurring between the complexes of same metal cations are called self exchange reactions. In self exchange reactions no net chemical reaction actually occurs because the products are indistinguishable from the reactant. Various self exchange reactions are shown in Table 7.5. On the other hand, the electron transfer occurring between the complexes of different metal cations are called cross reactions. In cross reactions net chemical reaction occurs.

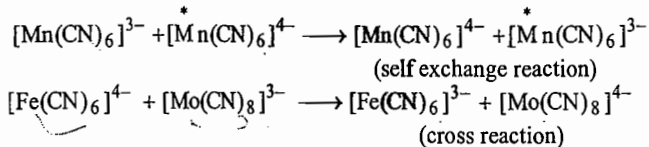

- (6) In outer sphere mechanisms bonds are neither broken nor made. For example :

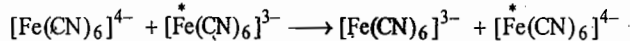

- (7) In outer sphere mechanism, the spin forbidden reaction are slow because these reactions require more activation energy.

The outer sphere mechanism is illustrated below by taking various examples :

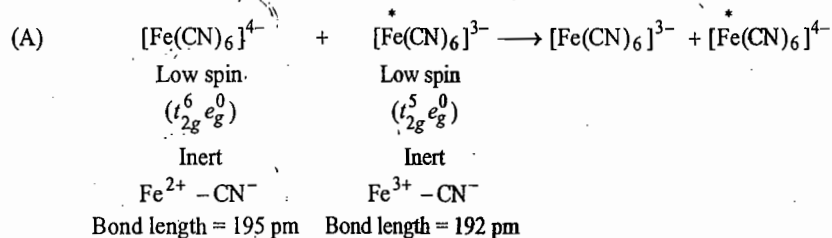

The rate of electron transfer is fast for the following reasons :

- (i) Both the complexes $[\text{Fe}(\text{CN})_6]^{4-}$ and $[\text{Fe}(\text{CN})_6]^{3-}$ are inert and electron transfer is faster than cyanide exchange for either reactant.
- (ii) Electron transfer is spin allowed.
- (iii) The electron transfer occurs from t_{2g} of $[\text{Fe}(\text{CN})_6]^{4-}$ to t_{2g} of $[\text{Fe}(\text{CN})_6]^{3-}$ complex. The t_{2g} orbitals point between the ligands and are not engaged in Fe - CN σ -bonding. Therefore, electron transfer becomes easy.
- (iv) Since t_{2g} orbitals point between the ligands, therefore, M-L distance do not change appreciably.
- (v) The ligand CN^- is unsaturated and a π -acceptor which facilitates the electron tunneling. Also since the CN^- ligand is a π -acceptor it, therefore, stabilizes complexes in lower oxidation state by formation of back π -bonding.

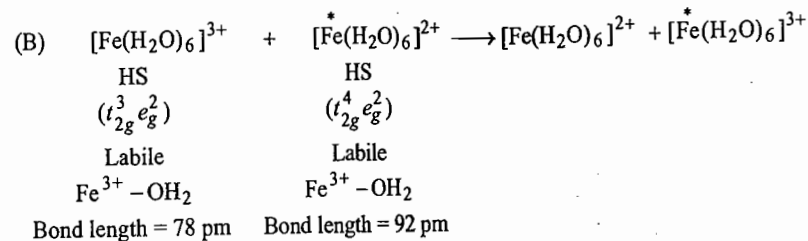

In this reaction, the reactants and products are the same except the position of radio active label. The energy of activation for this reaction is 32 kJ mol^{-1} which indicates that the rate of electron transfer is slow (second order rate constant $K_{11} = 4 \text{ L mol}^{-1} \text{ s}^{-1}$).

According to Frank-Condon principle, electron transfer takes place when the energy levels of the participating orbitals are same and the electron transfer takes place much more rapidly than the change in position of nuclei. Thus, during electron transfer M-L bond lengths remain unchanged.

In this reaction an electron is transferred from t_{2g} of Fe(II) to t_{2g} of Fe(III). The $\text{Fe}^{2+} - \text{OH}_2$ and $\text{Fe}^{3+} - \text{OH}_2$ bond lengths are 92 pm and 78 pm respectively, *i.e.*, $\text{Fe}^{3+} - \text{OH}_2$ bond length is 14 pm smaller than that of $\text{Fe}^{2+} - \text{OH}_2$. This indicate that the energy levels of the orbitals are not equal. Since the Fe-O bond length does not change during the electron transfer, this transfer of electron with out any input of energy will produce $[\text{Fe}(\text{H}_2\text{O})_6]^{3+}$ with Fe-O bond similar to Fe-O bond in $[\text{Fe}(\text{H}_2\text{O})_6]^{2+}$ and the $[\text{Fe}(\text{H}_2\text{O})_6]^{2+}$ with Fe-O bond similar to $[\text{Fe}(\text{H}_2\text{O})_6]^{3+}$. These two products are in vibrationally excited state. Both the products will release energy in the form of heat by vibrating to reach the equilibrium bond length. It seems that energy is created but it is the violation of the first law of thermodynamics. Consequently, an enough vibrational activation energy has been provided to each complex ion to bring them to the same energy levels and then transfer of electron to takes place.

Consequently, the electron transfer is most probable when an activation energy has been given to each complex ion. The activation energy causes the shortening of the bonds in $[\text{Fe}(\text{H}_2\text{O})_6]^{2+}$ and lengthening of the bonds in $[\text{Fe}(\text{H}_2\text{O})_6]^{3+}$ until the participating orbitals are of the same energy. In case of self exchange reaction, the Fe-O bond lengths have reached the same intermediate value. For cross reactions, the M-L bond lengths do not become same values but the orbital energy may be.

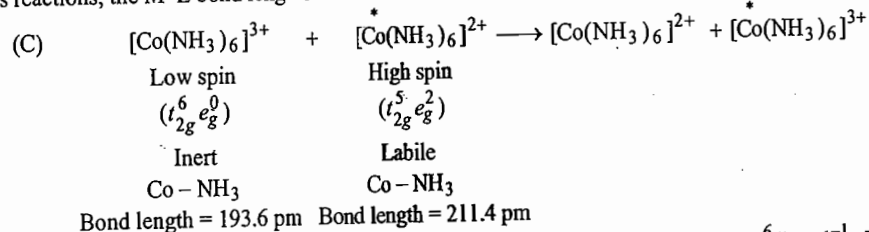

The rate of electron transfer for this reaction is slow (second order rate constant = $10^{-6} \text{ L mol}^{-1} \text{ s}^{-1}$) because of the following reasons :

(i) $[\text{Co}(\text{NH}_3)_6]^{3+}$ is low spin ($t_{2g}^6 e_g^0$) and $[\text{Co}(\text{NH}_3)_6]^{2+}$ is high spin ($t_{2g}^5 e_g^2$). Low spin $[\text{Co}(\text{NH}_3)_6]^{3+}$ has an electronic configuration t_{2g}^6 with all the metal d -electrons pointing in between the ligands. On the other hand, the high spin $[\text{Co}(\text{NH}_3)_6]^{2+}$ has an electronic configuration $t_{2g}^5 e_g^2$ with two e_g electrons pointing directly at the ligands. The electrons present in e_g orbitals cause more repulsion with the ligands than that of t_{2g} electrons. Therefore, $\text{Co}^{2+} - \text{NH}_3$ bond distance is larger than that of $\text{Co}^{3+} - \text{NH}_3$. The $\text{Co}^{3+} - \text{NH}_3$ bond distance is 193.6 pm and the $\text{Co}^{2+} - \text{NH}_3$ bond distance is 211.4 pm. In this case M-L bond lengths are different enough and more activation energy is needed to make them the same in the transition state.

Since Co (II) and Co (III) complexes are high spin and low spin respectively. No simple addition or removal of an electron can convert these configuration into one another. Therefore, it is necessary to excite the oxidation states before the reaction can occur as shown below:

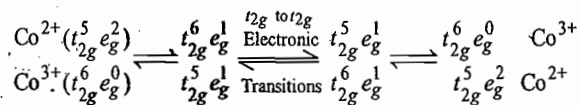

The electronic ground and excited states can also be written as follows:

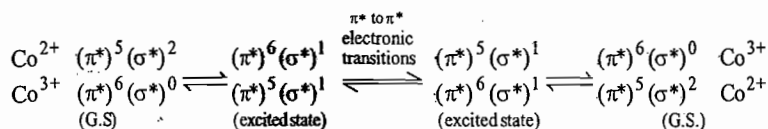

If the ligands are arranged in increasing order of crystal field splitting $\text{OX} < \text{H}_2\text{O} < \text{EDTA} < \text{NH}_3 < \text{en} < \text{phen} < \text{CN}^-$, transfer of electron from Co (II) to Co (III) is faster either at the weak end or the strong end but slow in the middle. Therefore, for example, Electron transfer from $[\text{Co}(\text{H}_2\text{O})_6]^{2+}$ to $[\text{Co}(\text{H}_2\text{O})_6]^{3+}$ is faster. H_2O is a weak ligand and Δ_o for low spin $[\text{Co}(\text{H}_2\text{O})_6]^{3+}$ is not very high. Thus, $[\text{Co}(\text{H}_2\text{O})_6]^{3+}$ can be easily excited to para magnetic $[\text{Co}(\text{H}_2\text{O})_6]^{3+}$ by input of small energy.

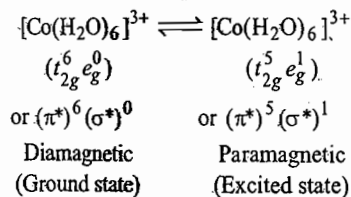

Since $[\text{Co}(\text{H}_2\text{O})_6]^{2+}$ is high spin and Δ_o is also very small. Thus, $[\text{Co}(\text{H}_2\text{O})_6]^{2+}$ can also be excited easily.

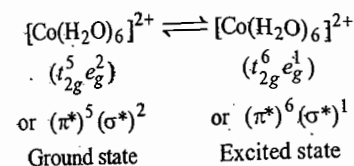

Now there is $\pi^* \rightarrow \pi^*$ (or $t_{2g} \rightarrow t_{2g}$) electron transfer from $[\text{Co}(\text{H}_2\text{O})_6]^{2+}$ in excited state to excited $[\text{Co}(\text{H}_2\text{O})_6]^{3+}$. The products so obtained are in excited states.

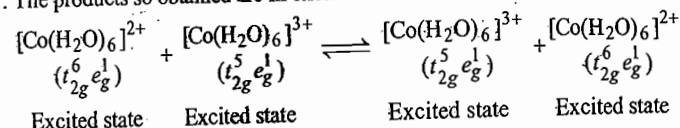

Finally the excited products go to the ground state.

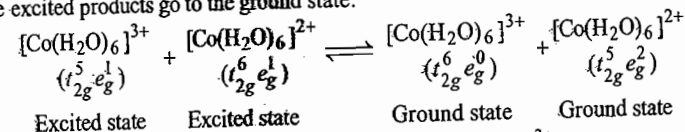

Rate of electron transfer from $[\text{Co}(\text{phen})_3]^{2+}$ to $[\text{Co}(\text{phen})_3]^{3+}$ is faster than that of $[\text{Co}(\text{NH}_3)_6]^{2+}$ to $[\text{Co}(\text{NH}_3)_6]^{3+}$. Since phenanthroline is a strong ligand, therefore, high spin Co (II) complex can easily excited to low spin Co (II) complex. Also, the π -acceptor and unsaturated nature of phen enhances the rate of electron transfer.

It is concluded that the rate of electron transfer $[\text{Co}(\text{NH}_3)_6]^{2+} - [\text{Co}(\text{NH}_3)_6]^{3+}$ and $[\text{Co}(\text{en})_3]^{2+} - [\text{Co}(\text{en})_3]^{3+}$ systems is slower than that of $[\text{Co}(\text{H}_2\text{O})_6]^{2+} - [\text{Co}(\text{H}_2\text{O})_6]^{3+}$ and $[\text{Co}(\text{phen})_3]^{2+} - [\text{Co}(\text{phen})_3]^{3+}$ systems. Second order rate constants for electron transfer for various Co (II) - Co (III) systems shown in Table 7.5 and 7.6 also supports this conclusion.

The rate of electron transfer is rapid between $[\text{CoF}_6]^{4-} - [\text{CoF}_6]^{3-}$ system. Both the complexes $[\text{CoF}_6]^{4-}$ and $[\text{CoF}_6]^{3-}$ are high spin complexes with the electronic configurations $t_{2g}^5 e_g^2$ and $t_{2g}^4 e_g^2$ respectively. Therefore, electron transfer from t_{2g} of $[\text{CoF}_6]^{4-}$ to t_{2g} of $[\text{CoF}_6]^{3-}$ occurs easily with input of little energy. Thus, the rate of electron transfer is fast.

The rate of electron transfer between $[\text{Co}(\text{diars})_3]^{2+} - [\text{Co}(\text{diars})_3]^{3+}$ is fast, where diars = *o*-phenylene bis dimethyl arsine. The complexes $[\text{Co}(\text{diars})_3]^{2+}$ and $[\text{Co}(\text{diars})_3]^{3+}$ are low spin with electronic configurations $(t_{2g}^6 e_g^1)$ and $(t_{2g}^6 e_g^0)$ respectively. The low spin $[\text{Co}(\text{diars})_3]^{3+}$ with $t_{2g}^6 e_g^0$ configuration requires less activation energy towards the low spin $(t_{2g}^5 e_g^1)$ configuration. Therefore, the rate of electron transfer is fast.

A $\pi^* \rightarrow \pi^*$ (i.e., $t_{2g} \rightarrow t_{2g}$) electron transfer takes place very rapidly when there is no need of excitation of electron before and following the electron transfer to takes place. (see Table 7.5) consider an electron transfer between $[\text{Ru}(\text{NH}_3)_6]^{2+}$ and $[\text{Ru}(\text{NH}_3)_6]^{3+}$.

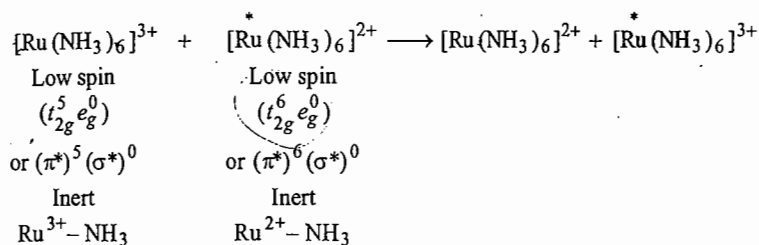

Bond length = 210.4 pm Bond length = 214.4 pm

Rate of electron transfer from $[\text{Ru}(\text{NH}_3)_6]^{2+}$ to $[\text{Ru}(\text{NH}_3)_6]^{3+}$ is rapid because:

- (i) Difference in M-L bond length in Ru (II) and Ru (III) complexes is small (*i.e.*, 4 pm).
- (ii) Electron transfer takes place from π^* of $[\text{Ru}(\text{NH}_3)_6]^{2+}$ to π^* of $[\text{Ru}(\text{NH}_3)_6]^{3+}$ without any input or a little input of energy.

Mode of electron transfer and rate constants for some outer sphere reactions is given in Table 7.7.

The rate of electron transfer between $[\text{Ru}(\text{phen})_3]^{2+}$ and $[\text{Ru}(\text{phen})_3]^{3+}$ or $[\text{Ru}(\text{CN})_6]^{4-}$ and $[\text{Ru}(\text{CN})_6]^{3-}$ is more rapid than the electron transfer between $[\text{Ru}(\text{NH}_3)_6]^{2+}$ and $[\text{Ru}(\text{NH}_3)_6]^{3+}$ because CN^- and phen ligands are π -acceptor and unsaturated in nature which facilitates the transfer of electron through tunnel.

Table 7.5 Second Order Rate Constants for Various Outer Self Exchange Sphere Electron Transfer Reactions at 25°C

Reactions	Rate Constant (k) $\text{L mol}^{-1} \text{s}^{-1}$
$[\text{Fe}(\text{CN})_6]^{4-} + [\text{Fe}(\text{CN})_6]^{3-}$	7.4×10^2
$[\text{Fe}(\text{Phen})_3]^{2+} + [\text{Fe}(\text{Phen})_3]^{3+}$	$\geq 3 \times 10^7$
$[\text{Fe}(\text{bpy})_3]^{2+} + [\text{Fe}(\text{bpy})_3]^{3+}$	$> 10^6$
$[\text{Mn}(\text{CN})_6]^{4-} + [\text{Mn}(\text{CN})_6]^{3-}$	$\geq 10^4$
$[\text{Ru}(\text{NH}_3)_6]^{2+} + [\text{Ru}(\text{NH}_3)_6]^{3+}$	8×10^2
$[\text{IrCl}_6]^{3-} + [\text{IrCl}_6]^{2-}$	10^3
$[\text{Os}(\text{bpy})_3]^{2+} + [\text{Os}(\text{bpy})_3]^{3+}$	$\geq 10^4$
$[\text{Ru}(\text{phen})_3]^{2+} + [\text{Ru}(\text{phen})_3]^{3+}$	$\geq 10^7$
$[\text{Fe}(\text{H}_2\text{O})_6]^{2+} + [\text{Fe}(\text{H}_2\text{O})_6]^{3+}$	4
$[\text{Co}(\text{H}_2\text{O})_6]^{2+} + [\text{Co}(\text{H}_2\text{O})_6]^{3+}$	~ 5

$[\text{Co}(\text{Phen})_3]^{2+} + [\text{Co}(\text{Phen})_3]^{3+}$	40
$[\text{Co}(\text{NH}_3)_6]^{2+} + [\text{Co}(\text{NH}_3)_6]^{3+}$	$< 10^{-9}$
$[\text{Co}(\text{en})_3]^{2+} + [\text{Co}(\text{en})_3]^{3+}$	1.4×10^{-4}
$[\text{Cr}(\text{H}_2\text{O})_6]^{2+} + [\text{Cr}(\text{H}_2\text{O})_6]^{3+}$	$\leq 2 \times 10^{-5}$
$[\text{V}(\text{H}_2\text{O})_6]^{2+} + [\text{V}(\text{H}_2\text{O})_6]^{3+}$	10^{-2}

Table 7.6 Second Order Rate Constants for Some Outer Sphere Cross Reactions at 25°C

Reactions	Rate Constant (k) $\text{L mol}^{-1} \text{s}^{-1}$
$[\text{Fe}(\text{CN})_6]^{4-} + [\text{IrCl}_6]^{2-}$	3.8×10^5
$[\text{Cr}(\text{H}_2\text{O})_6]^{2+} + [\text{Co}(\text{NH}_3)_6]^{3+}$	1.0×10^{-3}
$[\text{Cr}(\text{H}_2\text{O})_6]^{2+} + [\text{Co}(\text{en})_3]^{3+}$	3.4×10^{-4}
$[\text{Cr}(\text{H}_2\text{O})_6]^{2+} + [\text{Co}(\text{Phen})_3]^{3+}$	30
$[\text{Cr}(\text{H}_2\text{O})_6]^{2+} + [\text{Ru}(\text{NH}_3)_6]^{3+}$	1.2×10^2
$[\text{V}(\text{H}_2\text{O})_6]^{2+} + [\text{Co}(\text{NH}_3)_6]^{3+}$	2×10^{-2}
$[\text{V}(\text{H}_2\text{O})_6]^{2+} + [\text{Co}(\text{en})_3]^{3+}$	2×10^{-4}
$[\text{V}(\text{H}_2\text{O})_6]^{2+} + [\text{Co}(\text{Phen})_3]^{3+}$	3.8×10^3
$[\text{V}(\text{H}_2\text{O})_6]^{2+} + [\text{Ru}(\text{NH}_3)_6]^{3+}$	80
$[\text{Fe}(\text{CN})_6]^{4-} + [\text{Fe}(\text{Phen})_3]^{3+}$	10^8
$[\text{Cr}(\text{H}_2\text{O})_6]^{2+} + [\text{Ru}(\text{H}_2\text{O})_6]^{3+}$	2×10^2
$[\text{Fe}(\text{CN})_6]^{4-} + \text{MnO}_4^-$	6×10^4
$[\text{Fe}(\text{H}_2\text{O})_6]^{2+} + [\text{Fe}(\text{bpy})_3]^{3+}$	5.8×10^6

Cross Reactions

Electron transfer reaction between completely different complexes are called cross reactions. In these reactions there is a net chemical change and the rate of electron transfer is faster than the corresponding self exchange reactions (Table 7.6) in spite of an otherwise large activation energy (transfer involving at least one e_g electron). The large amount of activation energy is encountered by the change in free energy and as a result there is a net decrease in free energy. More is the decrease in free energy, faster will be the rate of electron transfer.

The decrease in free energy during electron transfer indicates that the energy of reactants is greater than that of the products and the free energy profile is not symmetric (see figure 7.26)

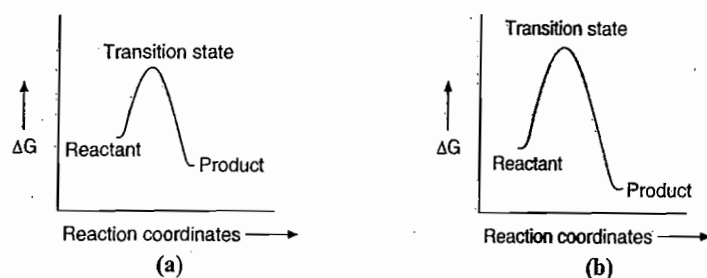

Figure 7.26. (a) Energy profile for self-exchange reactions
(b) Energy profile for cross reactions

Marcus and Hush has derived a relationship to calculate rate constants for cross reactions :

$$k_{12} = (k_{11}k_{22}K_{12}f)^{1/2}$$

where k_{11} and k_{22} are the rate constants for the two self exchange reactions.

k_{12} is the rate constant for cross reaction.

K_{12} is the equilibrium constant for overall cross reaction.

f is a statistical and steric factor and it describes a correction for the difference in free energies of the two reactants. It is generally close to unity.

Higher the value of equilibrium constant (K_{12}) for cross reaction, faster will be the rate of electron transfer. The equilibrium constant is linearly related with ΔG° as follows :

$$\Delta G^\circ = -RT \ln K$$

This indicates that for high value of K , higher will be the negative value of ΔG° and hence faster will be the rate of reaction.

Higher value of equilibrium constant for cross reaction indicates that rate constant for cross reactions are generally higher than those for the corresponding self exchange reactions.

Now let us consider the cross reaction:

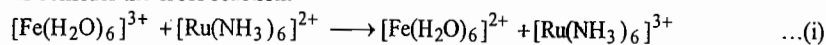

For this cross reaction, the self exchange reactions are :

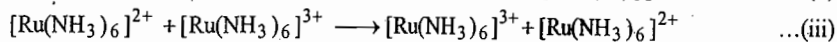
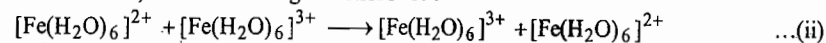

The rate constant k_{11} and k_{22} for the self exchange reactions (ii) and (iii) are observed to be $4.2 \text{ L mol}^{-1} \text{ s}^{-1}$ and $4.0 \times 10^3 \text{ L mol}^{-1} \text{ s}^{-1}$ respectively and the equilibrium constant (K_{12}) for cross reaction (i) is 2.1×10^{11} and $f = 0.85$. Then rate constant k_{12} for cross reaction (i) is calculated by the expression :

$$\begin{aligned} k_{12} &= (k_{11}k_{22}K_{12}f)^{1/2} \\ &= (4.2 \times 4.0 \times 10^3 \times 2.1 \times 10^{11} \times 0.85)^{1/2} \\ &= 5.48 \times 10^7 \text{ L mol}^{-1} \text{ s}^{-1} \end{aligned}$$

Thus, the calculated value of k_{12} by Marcus-Hush equation is found to be greater than those of k_{11} and k_{22} . It implies that the rate of electron transfer in cross reaction is faster than those of corresponding self exchanges.

Some examples of outer sphere self exchanges and cross reactions with their second order rate constants are given in Table 7.5 and 7.6 respectively.

(II) Inner Sphere Mechanism

In inner sphere electron transfer reactions, the oxidant and reductant share a ligand in the coordination sphere to form a bridged complex, the electron is then transferred through the bridging ligand.

Salient Features of Inner Sphere Mechanism

- (1) One complex (the reductant) is labile and the other (*i.e.*, the oxidant) is inert.
- (2) The inert complex possesses atleast one ligand capable of bridging two metal ions to form a bridged intermediate and this bridged intermediate is called a precursor complex.
- (3) Often, but not always, the bridging ligand is also transferred from oxidant to reductant. The transfer or non-transfer of bridging ligand depends upon the relative stabilities of the products. The ligand transfer is a good indicator that electron transfer takes place by inner sphere mechanism. If there is no bridging ligand, then electron transfer does not take place by inner sphere mechanism. However it may take place by outer sphere mechanism. If a bridging ligand (attached to inert complex) is available but not transfer, then the electron transfer may occur either by an inner or outer sphere mechanism.
- (4) Either e_g (σ^*) or t_{2g} (π^*) orbitals of both the reactants participate in electron transfer by inner sphere mechanism. In general these orbitals may be HOMO of the reductant and LUMO of oxidant. If both the reactants in an electron transfer reaction involve orbitals of same symmetry no or a little activation energy is required and electron transfer will be fast. If both the orbitals are of different symmetries, greater activation energy encompassing both structural deformation and electron configuration change is required. Such reaction will be slower than those requiring no electron configuration change. Electron transfer by inner sphere mechanism is faster when electron transfer takes place between e_g (or σ^*) orbitals of oxidant and reductant.
- (5) Inner sphere electron transfer reactions are faster than similar reaction occurring through outer sphere mechanism.
- (6) The rate of electron transfer increases if the bridging ligand possess unsaturation or extensive conjugation.

The electron transfer in inner sphere mechanism takes place through the following elementary steps in aqueous medium.

Formation of precursor complex

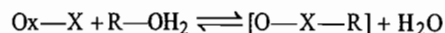

Activation of precursor complex

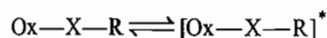

electron transfer

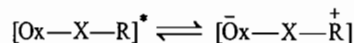

Dissociation to separate products

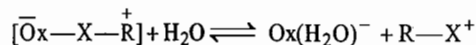

The rate law for the overall reaction

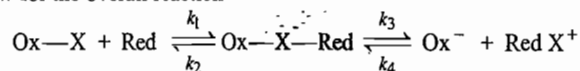

is
$$\text{Rate} = \frac{k_1 k_3}{k_2 + k_3} [\text{Ox}-\text{X}] [\text{Red}] \quad \dots (7.1)$$

where k_3 is the overall rate constant for 2nd and 3rd step.

If $k_3 \gg k_2$, then the rate determining step is the formation of the precursor complex and the rate law will be :

$$\text{Rate} = k_1 [\text{Ox}-\text{X}] [\text{Red}] \quad \dots (7.2)$$

If $k_2 \gg k_3$, then the rate determining step will be rearrangement and electron transfer within the intermediate (i.e., fission of the precursor complex). Thus, rate law will be :

$$\text{Rate} = \frac{k_1 k_3}{k_2} [\text{Ox}-\text{X}] [\text{Red}] \quad \dots (7.3)$$

Now let us discuss some important reaction involving electron transfer by inner sphere mechanism.

(A) Taube and his students have provided first reaction involving electron transfer by inner sphere mechanism. The overall reaction is :

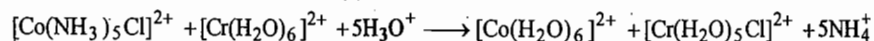

Low spin ($t_{2g}^6 e_g^0$)	High spin ($t_{2g}^3 e_g^1$)	High spin ($t_{2g}^5 e_g^2$)	— ($t_{2g}^3 e_g^0$)
or $(\pi^*)^6 (\sigma^*)^0$	or $(\pi^*)^3 (\sigma^*)^1$	or $(\pi^*)^5 (\sigma^*)^2$	or $(\pi^*)^3 (\sigma^*)^0$
Inert	Labile	Labile	Inert

In this reaction Co^{3+} is reduced by Cr^{2+} and the bridging ligand Cl^- is transferred from coordination sphere of cobalt to that of chromium.

(i) $[\text{Co}(\text{NH}_3)_5\text{Cl}]^{2+}$ is kinetically inert and Cl^- is the bridging ligand.

(ii) Electron transfer takes place from $e_g(\sigma^*)$ of $[\text{Cr}(\text{H}_2\text{O})_6]^{2+}$ to $e_g(\sigma^*)$ of $[\text{Co}(\text{NH}_3)_5\text{Cl}]^{2+}$.

Thus, electron transfer by inner sphere mechanism is fast (rate constant $(k) = 6 \times 10^5 \text{ L mol}^{-1} \text{ s}^{-1}$). The various steps of the mechanism of the reaction are shown below :

(i) Chlorine atom of inert $[\text{Co}(\text{NH}_3)_5\text{Cl}]^{2+}$ complex while remaining firmly attached to $\text{Co}(\text{III})$ replaces a water molecule from the labile $[\text{Cr}(\text{H}_2\text{O})_6]^{2+}$ to form a bridged intermediate.

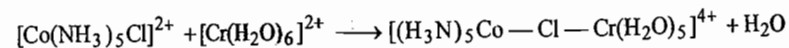

(ii) Electron transfer takes place from $\text{Cr}(\text{II})$ to $\text{Co}(\text{III})$ through Cl bridge in a manner as electron flow between two electrodes through salt bridge.

This step is the rate determining step. After transfer of electron from Cr^{2+} to Co^{3+} , Co^{3+} is converted to Co^{2+} and the complex becomes high spin and labile. On the other hand, Cr^{2+} is converted to Cr^{3+} and the complex becomes inert.

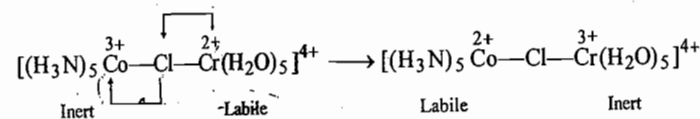

(iii) Since Co^{2+} is now labile and Cr^{3+} is inert, so the bridged complex intermediate dissociates in such a way that chlorine atom remains attached with chromium.

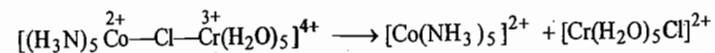

(iv) In the last step, the five coordinate $[\text{Co}(\text{NH}_3)_5]^{2+}$ species picks up water molecule to form $[\text{Co}(\text{NH}_3)_5(\text{H}_2\text{O})]^{2+}$ complex ion and this complex ion is hydrolyzed rapidly to give $[\text{Co}(\text{H}_2\text{O})_6]^{2+}$ ion.

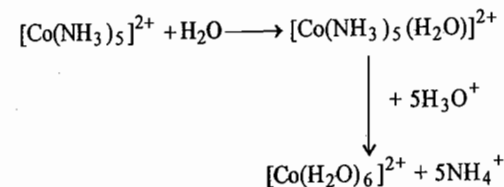

An evidence to support the inner sphere mechanism is that if the reaction is carried out in solution containing free isotopic chlorine (e.g., $^{36}\text{Cl}^-$), none of these labeled ions are found in the products. Conversely, if Cl^- ion in $[\text{Co}(\text{NH}_3)_5\text{Cl}]^{2+}$ is isotopically labeled with ^{36}Cl , the labeled ^{36}Cl is always transferred to Cr (III) coordination sphere.

The reaction is first order with respect to oxidant and first order with respect to reductant i.e., overall reaction is of second order.

$$\begin{aligned}\text{Rate} &= k [\text{oxidant}][\text{reductant}] \\ &= k [\text{Co}(\text{NH}_3)_5\text{Cl}]^{2+} [\text{Cr}(\text{H}_2\text{O})_6]^{2+}\end{aligned}$$

k is the second order rate constant.

Taube and his students have also provided a set of similar reactions. The general reaction is given below:

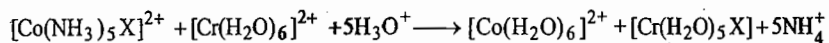

Where $\text{X}^- = \text{F}^-, \text{Cl}^-, \text{Br}^-, \text{I}^-, \text{NCS}^-, \text{NO}_3^-, \text{SCN}^-, \text{SO}_4^{2-}, \text{PO}_4^{3-}, \text{N}_3^-, \text{N}_2$ etc.

Now if X^- be the four halides i.e., $\text{F}^-, \text{Cl}^-, \text{Br}^-$ and I^- , then larger the size of halide, the faster is the rate of electron transfer.

Since size of halide increases from F^- to I^- as $\text{F}^- < \text{Cl}^- < \text{Br}^- < \text{I}^-$ and polarizability of the halides increases in the same order. In the bridged complex the halide is more polarized by higher charged cation i.e., Co^{3+} ion. As the halide is polarized, induced dipole moment is developed in X atom as shown in Figure 7.27. The induced dipole moment in the halogen atom attracts the electron from Cr^{2+} and then facilitates the rate of electron transfer. Thus, we can say that larger the size of halide, more will be its polarizability and more will be induced dipole and hence the easier be the electron transfer. Thus, the rate of electron transfer follow the order: $\text{F}^- < \text{Cl}^- < \text{Br}^- < \text{I}^-$.

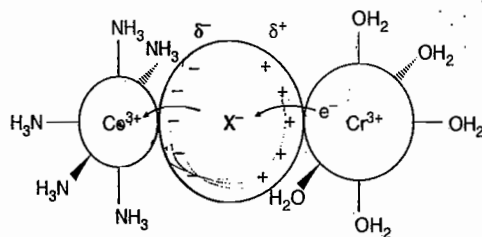
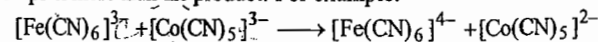
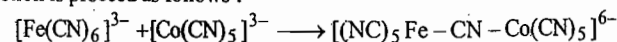

Figure 7.27 Polarization in X^- in bridged complex $[(\text{H}_3\text{N})_5\text{Co} - \text{X} - \text{Co}(\text{H}_2\text{O})_5]^{4+}$ and transfer of electron from Cr^{2+} to Co^{3+} through X .

There are so many cases in which electron transfer takes place by both inner sphere and outer sphere mechanisms. In such reactions which proceed by inner sphere pathway, electron transfer takes place in bridged complex without transfer of ligand. Such a condition arises when the bridging ligand stabilizes its original complex more than the product. For example:



This reaction is proceed as follows:



1. Electron transfer
2. Hydrolysis

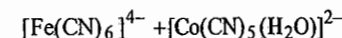

The $\text{Fe}^{2+} - \text{CN}^-$ bond is more stable than $\text{Co}^{3+} - \text{CN}^-$ bond. Therefore, electron transfer occurs without transfer of CN^- ligand.

Another example of electron transfer that occurs by inner sphere mechanism without transfer of ligand is:

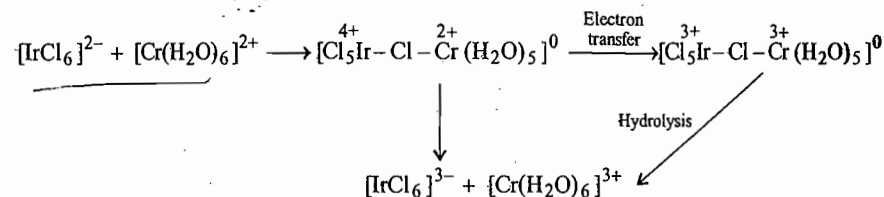

In the bridged complex or precursor complex, after electron transfer, the bond between the reduced metal ion and the bridge $[\text{Ir}(\text{III}) - \text{Cl}]$ is stronger than the bond between the oxidized metal ion and the bridge $[\text{Cr}(\text{III}) - \text{Cl}]$ and the later will be broken before the former. Thus, in this reaction $[\text{IrCl}_6]^{3-}$ and $[\text{Cr}(\text{H}_2\text{O})_6]^{3+}$ are more stable than $[\text{IrCl}_5(\text{H}_2\text{O})]^{2-}$ and $[\text{Cr}(\text{H}_2\text{O})_5\text{Cl}]^{2+}$ respectively, the other possible products. This reaction indicates that ligand transfer is not a requirement of the inner sphere mechanism.

Mode of electron transfer and rate constants for various inner sphere reactions is given in Table 7.8.

Remote Attack

If the two metal ions in an activated bridge complex are coordinated to the only one atom (say Cl^-), then this is called adjacent attack. Example of the adjacent attack is

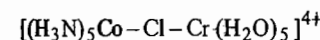

If the two metal ions in an activated bridge complex are coordinated to two different atoms of the bridging ligand, then it is called as remote attack. For example, consider the following reaction:

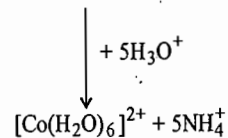
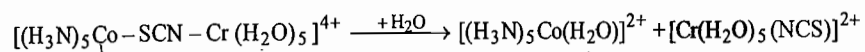
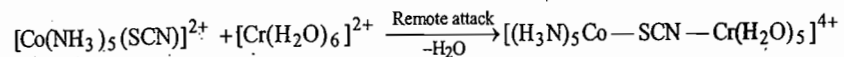

In the electron transfer reaction between $[\text{Co}(\text{NH}_3)_5(\text{SCN})]^{2+}$ and $[\text{Cr}(\text{H}_2\text{O})_6]^{2+}$, an adjacent attack also occurs to form the $[\text{Co}(\text{H}_2\text{O})_6]^{2+}$ and $[\text{Cr}(\text{H}_2\text{O})_5(\text{SCN})]^{2+}$ products.

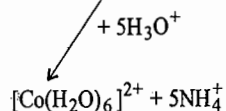
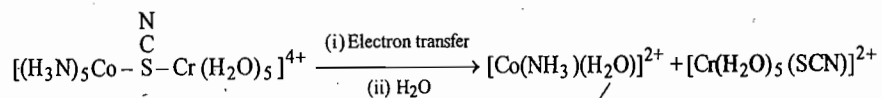
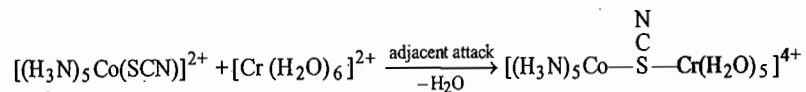

In this electron transfer reaction the yield of $[\text{Cr}(\text{H}_2\text{O})_5(\text{NCS})]^{2+}$ is 70% and in the later the yield of $[\text{Cr}(\text{H}_2\text{O})_5(\text{SCN})]^{2+}$ is only 30%.

Another example of remote attack is given below:

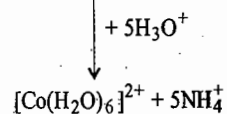
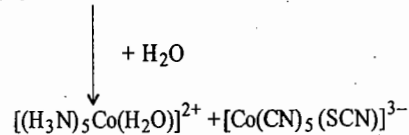
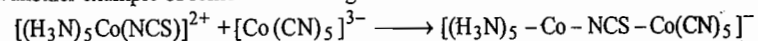

Since $[\text{Co}(\text{NH}_3)_5]^{3+}$ is a hard acid unit and $[\text{Co}(\text{CN})_5]^{3-}$ is a soft acid unit, the stable N-bonded $[\text{Co}(\text{NH}_3)_5\text{NCS}]^{2+}$ is converted to more stable $[\text{Co}(\text{CN})_5(\text{SCN})]^{3-}$.

A remote attack also forms the linkage isomers as shown in the following reaction:

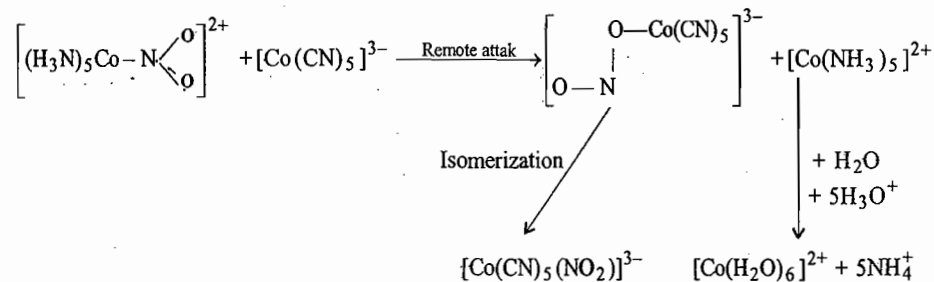

In this reaction the kinetically favoured nitrito complex, $[\text{Co}(\text{CN})_5\text{ONO}]^{3-}$ isomerises to thermodynamically favoured the complex, $[\text{Co}(\text{CN})_5(\text{NO}_2)]^{3-}$.

Table 7.7 Mode of Electron Transfer and Rate Constants for Some Outer Sphere Reaction

Reductant	Electronic Configuration	Oxidant	Electronic Configuration	Electron Transfer	Rate Constant $k, \text{L mol}^{-1} \text{s}^{-1}$
$[\text{Cr}(\text{H}_2\text{O})_6]^{2+}$		$[\text{Co}(\text{NH}_3)_6]^{3+}$			1.0×10^{-3}
$[\text{Cr}(\text{H}_2\text{O})_6]^{2+}$	$(\pi^*)^3 (\sigma^*)^1$	$[\text{Co}(\text{en})_3]^{3+}$	$(\pi^*)^6 (\sigma^*)^0$	$\sigma^* \rightarrow \sigma^*$	3.4×10^{-4}
$[\text{Cr}(\text{H}_2\text{O})_6]^{2+}$		$[\text{Co}(\text{Phen})_3]^{3+}$			30
$[\text{Cr}(\text{H}_2\text{O})_6]^{2+}$	$(\pi^*)^3 (\sigma^*)^1$	$[\text{Ru}(\text{NH}_3)_6]^{3+}$	$(\pi^*)^5 (\sigma^*)^0$	$\sigma^* \rightarrow \pi^*$	2×10^2
$[\text{V}(\text{H}_2\text{O})_6]^{2+}$		$[\text{Co}(\text{NH}_3)_6]^{3+}$			10^{-2}
$[\text{V}(\text{H}_2\text{O})_6]^{2+}$	$(\pi^*)^3 (\sigma^*)^0$	$[\text{Co}(\text{en})_3]^{3+}$	$(\pi^*)^6 (\sigma^*)^0$	$\pi^* \rightarrow \sigma^*$	7.2×10^{-4}
$[\text{V}(\text{H}_2\text{O})_6]^{2+}$		$[\text{Co}(\text{Phen})_3]^{3+}$			3.8×10^3
$[\text{V}(\text{H}_2\text{O})_6]^{2+}$	$(\pi^*)^3 (\sigma^*)^0$	$[\text{Ru}(\text{NH}_3)_6]^{3+}$	$(\pi^*)^5 (\sigma^*)^0$	$\pi^* \rightarrow \pi^*$	80

Table 7.8 Mode of Electron Transfer and Rate Constants for Various Inner Sphere Electron Transfer Reactions.

Oxidant	Electronic Configuration	Reductant					
		$[\text{V}(\text{H}_2\text{O})_6]^{2+}$			$[\text{Cr}(\text{H}_2\text{O})_6]^{2+}$		
		Electronic Configuration	Electron Transfer	Rate Constant k $\text{L mol}^{-1} \text{s}^{-1}$	Electronic Configuration	Electron Transfer	Rate Constant k $(\text{L mol}^{-1} \text{s}^{-1})$
$[\text{Co}(\text{NH}_3)_5\text{Cl}]^{2+}$	$(\pi^*)^6(\sigma^*)^0$	$(\pi^*)^3(\sigma^*)^0$	$\pi^* \rightarrow \sigma^*$	7.6	$(\pi^*)^3(\sigma^*)^1$	$\sigma^* \rightarrow \sigma^*$	6.0×10^5
$[\text{Co}(\text{NH}_3)_5\text{Br}]^{2+}$				25			1.4×10^6
$[\text{Co}(\text{NH}_3)_5\text{I}]^{2+}$				13			3.4×10^6
$[\text{Ru}(\text{NH}_3)_5\text{Cl}]^{2+}$	$(\pi^*)^5(\sigma^*)^0$	$\pi^* \rightarrow \sigma^*$	—	—	—	—	3.5×10^4
$[\text{Ru}(\text{NH}_3)_5\text{Br}]^{2+}$			—	—	—	2.2×10^3	
$[\text{Ru}(\text{NH}_3)_5\text{I}]^{2+}$			—	—	—	5×10^2	

Acceleration of Rate of Electron Transfer on going from Outer Sphere to Inner Sphere Mechanism for Similar Reactions

Electron transfer from $[\text{Cr}(\text{H}_2\text{O})_6]^{2+}$ to $[\text{Co}(\text{NH}_3)_6]^{3+}$ takes place by outer sphere mechanism but the rate of electron transfer is very slow ($k = 1.6 \times 10^{-3} \text{ L mol}^{-1} \text{ s}^{-1}$) because electron transfer takes place from $[\text{Cr}(\text{H}_2\text{O})_6]^{2+}$ to $[\text{Co}(\text{NH}_3)_6]$ and after transfer of electron there is an appreciable change in bond length which requires a high activation energy.

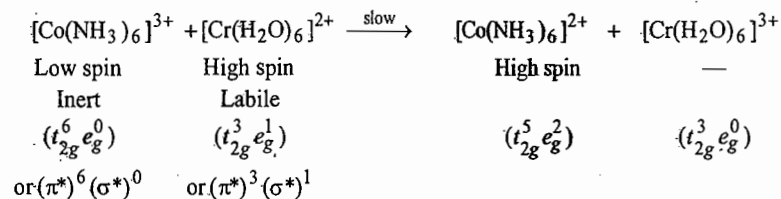

This reaction does not occur by inner sphere mechanism because the inert complex $[\text{Co}(\text{NH}_3)_6]^{3+}$ has no bridging ligand.

On the other hand, if one ammonia ligand on $\text{Co}(\text{III})$ is replaced by Cl^- ligand, reaction would occur by inner sphere mechanism because Cl^- ion is transferred to the oxidized reductant, and the rate of reaction is large ($k = 6 \times 10^5 \text{ L mol}^{-1} \text{ s}^{-1}$). Electron transfer by inner sphere mechanism has been tremendously accelerated relative to the outer sphere mechanism for the similar reaction. The acceleration of electron transfer by inner sphere mechanism relative to outer sphere mechanism for

similar reaction can be explained on the basis of symmetries of the reductant orbital from which an electron is to be transferred and the oxidant orbital into which the electron goes.

The general observations obtained from Table 7.7 and 7.8 are given in Table 7.9.

Table 7.9 : Acceleration of Rate of Electron Transfer on going from Outer Sphere to Inner Sphere Mechanism

HOMO	LUMO	Example	Acceleration of Rate of Electron Transfer from Outer Sphere to Inner Sphere Mechanism for Similar Reaction
σ^*	σ^*	$\text{Cr}^{2+} / \text{Co}^{3+}$	10^{10}
σ^*	π^*	$\text{Cr}^{2+} / \text{Ru}^{3+}$	10^2
π^*	σ^*	$\text{V}^{2+} / \text{Co}^{3+}$	10^4
π^*	π^*	$\text{V}^{2+} / \text{Ru}^{3+}$	No acceleration

From the Table 7.9, it is concluded that, if the electron transfer takes place from π^* of the reductant to π^* of the oxidant, then this electron transfer is considered to be occurring by outer sphere mechanism but by inner sphere mechanism.

In general, rate of electron transfer acceleration occurs on going from an outer sphere to inner sphere mechanism in similar reaction. The maximum acceleration occurs when HOMO and LUMO of both reductant and oxidant is σ^* . If both HOMO and LUMO are π^* then electron transfer occurs by outer sphere mechanism and no acceleration occurs on going from outer sphere to inner sphere mechanism. In other reactions when HOMO and LUMO are σ^* and π^* or π^* and σ^* respectively, activation energy is required for electron transfer to or from σ^* orbital because in such cases bond length is changed during transfer of electron and thus, there is acceleration in rate of electron transfer on going from outer sphere to inner sphere mechanism.

Inner Sphere Reactions with Complexes Containing Organic Bridging Ligands

Most extensively studied complexes containing organic bridging ligands are carboxylate complexes such as pentaamminebenzoatecobalt(III) (Fig. 7.28) and amine complexes such as pentaammineisonicotinamide cobalt(III) complexes (Fig. 7.29).

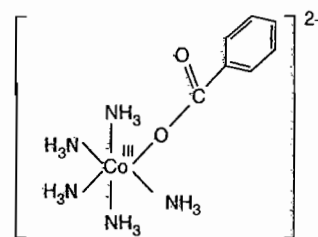

Fig. 7.28

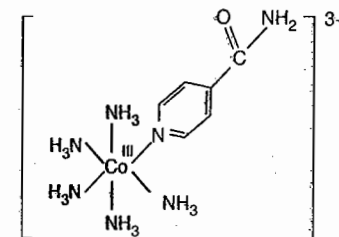
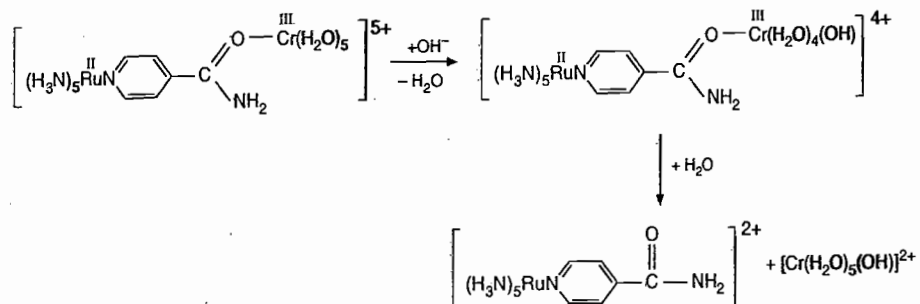

Fig. 7.29

second route (or k_1 path) depends on $[\text{OH}^-]$. The hydroxide ion abstracts proton from Cr(III)-bound water of the successor complex and dissociates to give products.



The third route (or k_2 path) depends on $[\text{OH}^-]$ as well as excess of $[\text{Cr}(\text{II})]$. In this path, the OH^- ligand in $\left[(\text{H}_3\text{N})_5\text{Ru}^{\text{II}} \text{---} \text{C}(\text{O})\text{---} \text{Cr}^{\text{III}}(\text{H}_2\text{O})_4(\text{OH}) \right]^{4+}$ complex ion functions as bridge ligand between this complex ion and unreacted Cr(II) and a bridge of the type $\text{---} \text{C}(\text{O})\text{---} \text{Cr}^{\text{III}}\text{---} \text{OH} \text{---} \text{Cr}^{\text{II}}$ is formed [Fig. 7.31(A)] and an inner sphere electron transfer takes place from Cr(II) to Cr(III) resulting in the species (B).

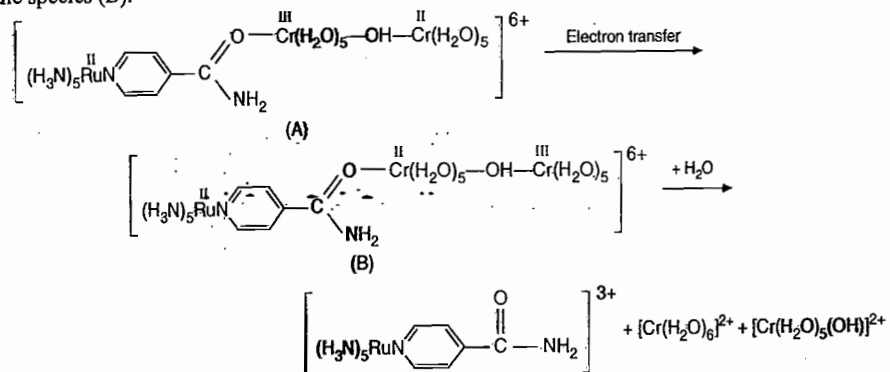

Fig. 7.31

Since Cr(II) is labile and Cr(III) is inert, therefore, Cr(II) is more susceptible to substitution reactions than Cr(III). The complex [7.31(b)] which now contains Cr(II) instead of Cr(III) decomposes

to give products $\left[(\text{H}_3\text{N})_5\text{Ru}^{\text{II}} \text{---} \text{C}(\text{O})\text{---} \text{NH}_2 \right]^{2+}$, $[\text{Cr}(\text{H}_2\text{O})_5(\text{OH})]^{2+}$ and $[\text{Cr}(\text{H}_2\text{O})_6]^{2+}$. Since the k_2 path is catalyzed by excess of Cr(II), this path is the most rapid of the three decomposition paths.

TWO ELECTRON TRANSFER

The simultaneous transfer of two or more electrons by an outer sphere mechanism has not yet been established because it would involve equalizing bond lengths in species of which one contains two or more bonding electrons than the other and requires high activation energy. The two electron transfer has been observed to take place by inner sphere mechanism.

One of the best two electron transfer reactions, for example, is the $[\text{Pt}(\text{en})_2]^{2+}$ catalyzed exchange of radioactive $^*\text{Cl}^-$ for chloride bound to *trans*- $[\text{Pt}(\text{en})_2\text{Cl}_2]^{2+}$.

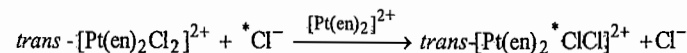

The rate law for this reaction is :

$$\text{Rate} = k [\text{Pt}^{\text{II}}] [\text{Pt}^{\text{IV}}] [^*\text{Cl}^-]$$

where Pt^{II} and Pt^{IV} stand for $[\text{Pt}(\text{en})_2]^{2+}$ and $[\text{Pt}(\text{en})_2\text{Cl}_2]^{2+}$ respectively. The mechanism proposed involves rapid addition of radioactive chloride ($^*\text{Cl}^-$) to the $[\text{Pt}(\text{en})_2]^{2+}$ to form a five coordinate $[\text{Pt}(\text{en})_2^*\text{Cl}]^+$ which then forms a six coordinate, inner sphere bridged binuclear complex with $[\text{Pt}(\text{en})_2\text{Cl}_2]^{2+}$. The transfer of two σ^* electrons accompanied by the transfer of a bridging chloride in the opposite direction between the Pt(II) and Pt(IV) complexes readily occurs followed by breaking of the bridged complex.

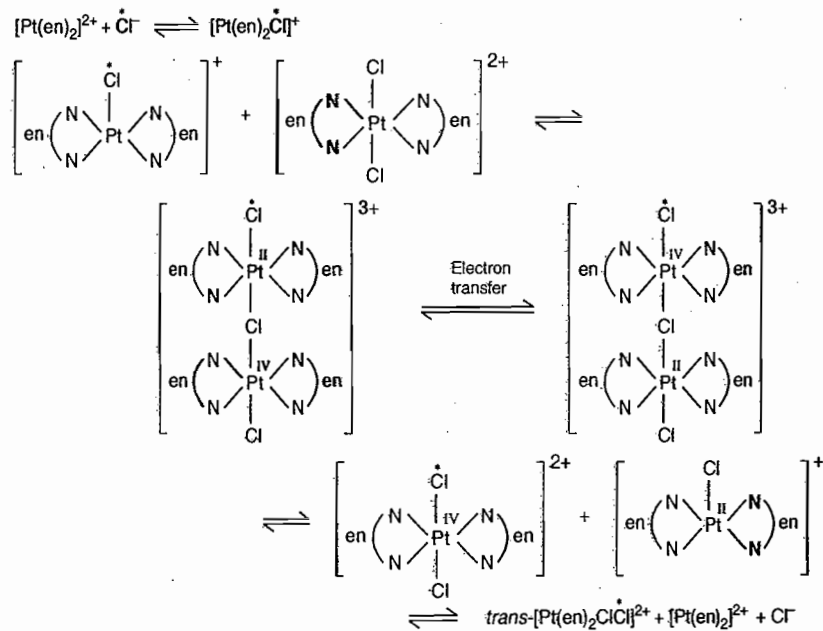

COMPLEMENTARY AND NON-COMPLEMENTARY REACTIONS

Redox reactions in which the oxidant and reductant change their oxidation states by an equal number of units are called complementary reactions. For examples :

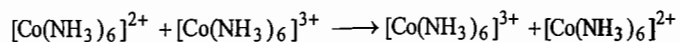
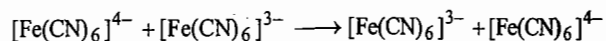
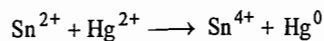
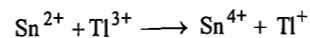

Non-complementary reactions, on the other hand, are reactions in which oxidation states of the reactants (oxidants and reductants) change by a different number of units. In these reactions, different number of molecules of oxidant and reductant are involved in the stoichiometric equations. For example,

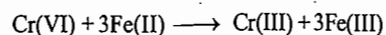
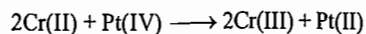
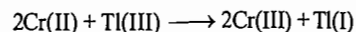
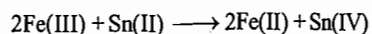
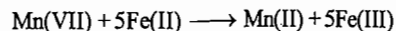

Non-complementary reactions proceed in multiple steps, each step involving a single electron transfer. In these reactions, intermediates of unstable oxidation states are formed. For example, reduction of Cr(VI) by Fe(II) has been proposed to take place in the formation of Cr(V) and Cr(IV) as intermediates before the product Cr(III) is formed.

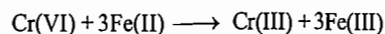

Mechanism of this reaction is :

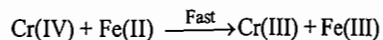
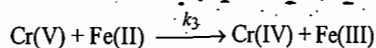
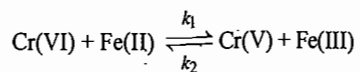

The rate law for such a mechanism is given as :

$$\text{Rate} = \frac{k_1 k_3 [\text{Cr(VI)}] [\text{Fe(II)}]^2}{k_3 [\text{Fe(II)}] + k_2 [\text{Fe(III)}]}$$

Similarly, in the oxidation of Fe(II) by Tl(III) has been found to be first order with respect to each reactant, suggesting the formation of Tl(II) as an intermediate.



Mechanism :

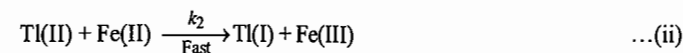
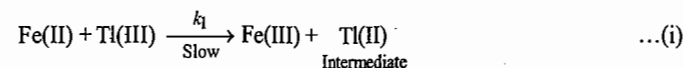

When Fe(III) forms in the course of reaction or when it is added initially, the reverse of reaction (i) :

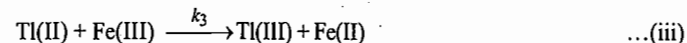

competes for the Tl(II) formed.

Since many transition metals form compounds in which they exhibit a range of oxidation states differing by one unit, their ions are used as good catalyst for non-complementary redox reactions. Thus, for example, the oxidation of Cr(III) by peroxodisulphate is catalyzed by Ag^+ possibly through the formation of various intermediates and the following mechanism has been suggested :

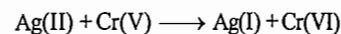
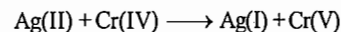
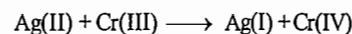
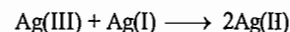
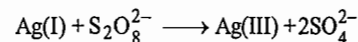

Synthesis of Coordination Compounds using Electron Transfer Reactions

The separation of a racemic mixture into its *d*- and *l*-forms is called resolution. Since the physical and chemical properties of the *d*- and *l*-forms (*i.e.*, enantiomers) of a complex such as $[\text{Co}(\text{en})_3]\text{Cl}_3$ are identical except for the interaction with plane polarized light, they can not be separated by ordinary method like fractional distillation, fractional crystallization etc. If the chloride ions of $[\text{Co}(\text{en})_3]\text{Cl}_3$ are replaced by optically active anion, like *d*-tartrate ion, the resulting salts might differ in properties such as solubility. $[\text{Co}(\text{en})_3]^{3+}$ is easily resolved by replacing two chloride ions by the *d*-tartare ion, followed by fractional crystallization. When *d*-tartrate ion is added to the solution of racemic mixture of *d*- and *l*-isomers of $[\text{Co}(\text{en})_3]\text{Cl}_3$ complex, two of the Cl^- ions in *d*- and *l*-isomers are replaced by the *d*-tartrate ion abbreviated as (*d*-tart) $^{2-}$ or (+-tart) $^{2-}$ and two salts (+)- $[\text{Co}(\text{en})_3]\text{Cl}(\textit{d-tart})$ abbreviated as (+)(+) and (-)- $[\text{Co}(\text{en})_3]\text{Cl}(\textit{d-tart})$ abbreviated as (-)(+) is formed. These salt pairs are not mirror images because the *d*-tartrate ion has same configuration in each salt and these salts are, therefore, diastereomers.

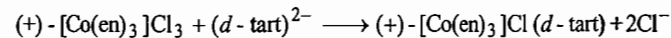

Upon crystallization, the (+)- $[\text{Co}(\text{en})_3]\text{Cl}(\textit{d-tart})$ is precipitated from the solution leaving (-)- $[\text{Co}(\text{en})_3]\text{Cl}(\textit{d-tart})$ in the mother liquor. The mother liquor becomes a thick gelatinous mass before crystallization of (-)- $[\text{Co}(\text{en})_3]\text{Cl}(\textit{d-tart})$. The separated diastereomers containing *d*-tartrate can be converted to the active chloride enantiomers (*i.e.*, active *d*- and *l*-chloride complexes) by adding concentrated HCl which is an optically inactive compound.

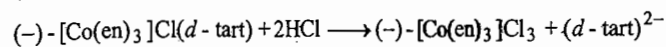
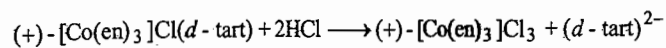

The soluble $(-)-[\text{Co}(\text{en})_3]\text{Cl}(d\text{-tart})$ can also be separated from the mother liquor by the use of electron transfer reaction. When a small amount of ethylenediamine and $\text{CoCl}_2 \cdot 6\text{H}_2\text{O}$ which form $[\text{Co}(\text{en})_3]\text{Cl}_2$, are added to the mother liquor, electron transfer reaction by outer sphere mechanism occurs between $[\text{Co}(\text{en})_3]\text{Cl}_2$ formed with equal amount of the d - and l -enantiomers and $(-)-[\text{Co}(\text{en})_3]\text{Cl}(d\text{-tart})$.

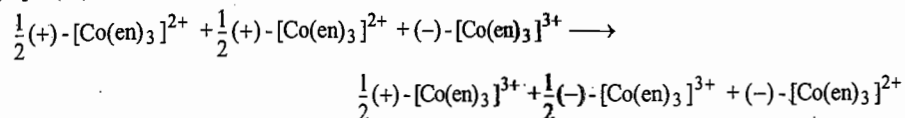

The latter form $(-)-[\text{Co}(\text{en})_3]^{2+}$ rapidly racemizes to $(+)$ - and $(-)-[\text{Co}(\text{en})_3]^{2+}$ due to the addition of small amount of ethylenediamine and $\text{CoCl}_2 \cdot 6\text{H}_2\text{O}$. The other products of the electron transfer reaction is a racemic mixture of the enantiomers of $[\text{Co}(\text{en})_3]^{3+}$. The $(+)$ -isomer of the newly formed $\text{Co}(\text{III})$ complex is precipitated leaving $(-)$ -isomer in the mother liquor, which again undergoes electron transfer with $[\text{Co}(\text{en})_3]^{2+}$ and again a racemic mixture of $[\text{Co}(\text{en})_3]^{3+}$ is obtained, the $(+)$ -isomer of which again precipitates leaving $(-)$ -isomer in the solution. In this process, all of the $(-)$ -enantiomer originally present are converted into the $(+)$ -enantiomer. Alternatively if l -tartrate is used instead of d -tartrate as starting material, all of the $(+)$ -enantiomer can be converted into $(-)$ -enantiomer. In this process the yield is approximately 75%.

Synthesis of $[\text{Cr}(\text{bpy})_2(\text{H}_2\text{O})_2]^{3+}$ or $[\text{Cr}(\text{phen})_2(\text{H}_2\text{O})_2]^{3+}$

Electrochemical reduction of $[\text{Cr}(\text{phen})_3]^{3+}$ and $[\text{Cr}(\text{bpy})_3]^{3+}$ in aqueous solution leads ultimately to the production of $[\text{Cr}(\text{phen})_2(\text{H}_2\text{O})_2]^{3+}$ and $[\text{Cr}(\text{bpy})_2(\text{H}_2\text{O})_2]^{3+}$.

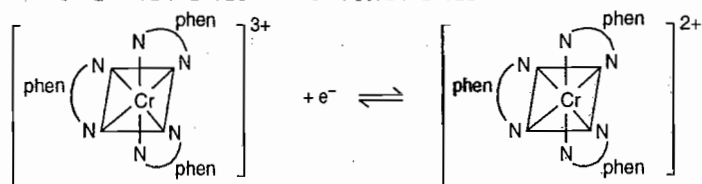

$$E_{1/2} = 0.49 \text{ V}$$

In this reaction, the $[\text{Cr}(\text{phen})_3]^{3+}$ formed is labile to substitution and one o -phenanthroline ligand is replaced by two water molecules and $[\text{Cr}(\text{phen})_2(\text{H}_2\text{O})_2]^{2+}$ is formed. This ion undergoes electron transfer with $[\text{Cr}(\text{phen})_3]^{3+}$ which is presuming to be still present to produce the final product, $[\text{Cr}(\text{phen})_2(\text{H}_2\text{O})_2]^{3+}$.

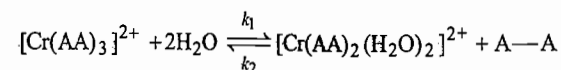

where AA is either o -phen or bpy.

It has been experimentally observed that some relatively inert substances may enter into a reaction in such a way either to direct the reactions to different products or to catalyze the reaction.

Delepine has studied Rhodium(III) complexes of amine ligands in aqueous and water-ethanol solutions. Delepine has observed that pyridine reacts with $\text{Na}_3[\text{RhCl}_6]$ in aqueous solution to give $[\text{Rh}(\text{py})_3\text{Cl}_3]$. This compound is insoluble. Therefore, the reaction stops at this stage and further substitution of a chloride by fourth molecule of pyridine to give $[\text{Rh}(\text{py})_4\text{Cl}_2]^+$ becomes difficult and requires lengthy reflux. To overcome this difficulty, Delepine has added ethanol with the expectation that the complex $[\text{Rh}(\text{py})_3\text{Cl}_3]$ becomes soluble with the formation of $[\text{Rh}(\text{py})_4\text{Cl}_2]^+$. In this reaction, ethanol as a solvent behaves as a catalyst and diverts the reaction to form $[\text{Rh}(\text{py})_4\text{Cl}_2]^+$ rather than $[\text{Rh}(\text{py})_3\text{Cl}_3]$ complex. As a result of addition of ethanol, the reaction between $\text{Na}_3[\text{RhCl}_6]$ and pyridine in aqueous-ethanol solution proceeds immediately and qualitatively obtain the crystals of $[\text{Rh}(\text{py})_4\text{Cl}_2]^+$ product at room temperature without the formation of another intermediate.

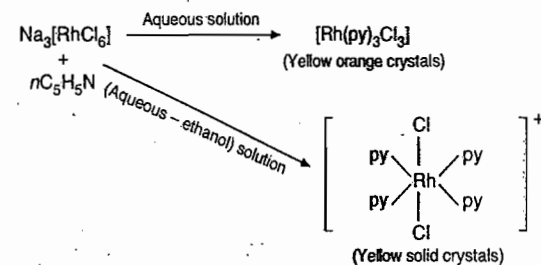

The mechanism and kinetics of the above reaction are quite similar to that for the $\text{Pt}(\text{II})-\text{Pt}(\text{IV})$ redox reaction discussed earlier. The first step involves the reduction of $\text{Rh}(\text{III})$ to $\text{Rh}(\text{I})$ by ethanol. But the initial species in which $\text{Rh}(\text{I})$ is produced is not known. Although, it is observed that $[\text{Rh}(\text{py})_4]^+$ is formed rapidly as pyridine is used in excess. The condition are now set for the formation of $[\text{Rh}(\text{py})_4\text{Cl}_2]^+$ by a mechanism identical to a $\text{Pt}(\text{II})-\text{Pt}(\text{IV})$ two electron transfer reaction. It is experimentally observed that $[\text{Rh}(\text{py})_3\text{Cl}_3]$ does not involved in this mechanism. The addition of ethanol to the aqueous solution leads to the formation of $[\text{Rh}(\text{py})_4\text{Cl}_2]^+$ not by solubilizing $[\text{Rh}(\text{py})_3\text{Cl}_3]$ but by rather acting as a reducing agent.

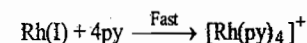
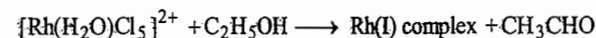

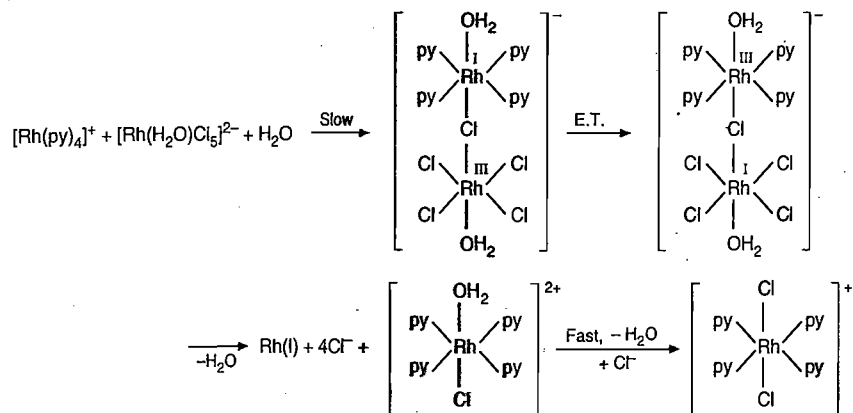

Other Rh(III) compounds can also be prepared by the same technique, but the nature of the product depends on the nature of ligands involved and the reaction conditions. For example, even in the presence of ethanol, $[\text{Rh}(\text{SCN})_6]^{3-}$ reacts with pyridine to give only $[\text{Rh}(\text{py})_3(\text{SCN})_3]$ where SCN^- is bonded to Rh(III) through S-stom. In this reaction *trans*- $[\text{Rh}(\text{py})_4(\text{SCN})_2]^+$ ion does not form because of the steric hindrance between pyridine and SCN^- and, therefore, four pyridine ligands can not lie flat in a plane about Rh(III), instead the pyridine ligands arrange as four bladed propeller about Rh(III). Since M—SCN linkage is bent $\left(\begin{array}{c} \text{M} \text{---} \text{S} \text{---} \text{C} \equiv \text{N} \\ \quad \quad \quad \backslash \\ \quad \quad \quad \text{N} \end{array} \right)$, there will be repulsion between the bent SCN^- ligand and the non-planar pyridine ligands.

PHOTOCHEMICAL REACTIONS

If a transition metal complex absorbs light radiations and goes in an excited state, its redox properties may change drastically. The complex in its excited state may undergo several kind of energy transfer, out of which luminescence is most straight-forward. In this process light is reemitted as the excited state returns to the ground state (a radiative process). Alternatively, energy may be converted to vibrational energy and dissipated thermally to the environment as the complex returns to the ground state (internal conversion). An important and widely studied complex in this area is $[\text{Ru}(\text{bpy})_3]^{2+}$ ion. This complex ion shows an intense metal to ligand charge transfer absorption band at 492 nm. Absorption of a photon at this wavelength causes a transfer of an electron from the highest occupied molecular orbital (HOMO) t_{2g}^6 set of Rh(II) to the lowest unoccupied molecular orbital (LUMO) *i.e.*, to empty π^* orbital of one of the bipyridyl ligands abbreviated as bpy to give a singlet complex with electronic configuration $t_{2g}^5 \pi^{*1}$. This transition is spin allowed and the resulting complex can be described as $[\text{Ru}^{\text{III}}(\text{bpy})_2(\text{bpy}^-)]^{2+}$. This complex undergoes rapid intersystem crossing without light emission to give the lower energy and relatively long lived triplet state complex $[\text{Ru}^{\text{III}}(\text{bpy})(\text{bpy}^-)]^{2+}$.

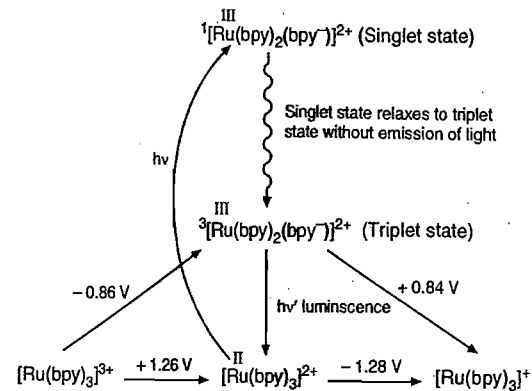
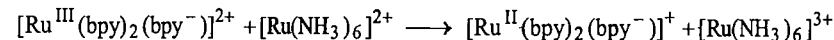
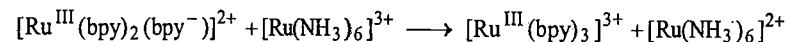

Fig. 7.32

The hole created at the ruthenium centre enhances its electron attracting ability and as a result this cation in excited state behaves as much better oxidizing agent as compared to its ground state. Furthermore, the availability of an electron in π^* of a ligand (bpy) makes the excited state cation a much better reducing agent as compared to the ground state cation.

From Fig. 7.32, it is seen that $[\text{Ru}^{\text{III}}(\text{bpy})_2(\text{bpy}^-)]^{2+}$ is a better oxidizing agent than ground state, $[\text{Ru}(\text{bpy})_3]^{2+}$ by $(0.84 + 1.28) = 2.12$ volts and better reducing agent by $(0.86 \text{ V} + 1.26 \text{ V}) = 2.12$ volts. One set of photochemical redox reactions is:



Some complexes can be excited by the *d-d* transitions and enhance the rate of substitution reactions. In these complexes an electron is excited from t_{2g} set to e_g set (in octahedral complexes) and increases the lability of complexes as the increased electron density in e_g orbitals increases the M—L bond length and weakened the M—L bond. Photosubstitution reactions of complexes such as $[\text{Cr}(\text{NH}_3)_5\text{X}]^{2+}$, $[\text{Cr}(\text{NH}_3)_4\text{X}_2]^+$ and $[\text{Cr}(\text{NH}_3)_3\text{Cl}_3]$ have been widely studied.

Fill in the Blanks

- $[\text{Cu}(\text{en})_3]^{2+}$ is stable than $[\text{Ni}(\text{NH}_3)_6]^{2+}$. *T₀ d⁹*
- The complex of Cu^{2+} is stable than the complex of Zn^{2+} with same ligand.
- $[\text{Co}(\text{CN})_6]^{3-}$ is inert than $[\text{Rh}(\text{CN})_6]^{3-}$.
- Electron transfer reactions are of order. *T₀ d⁸*
- In electron transfer reaction, electron transfer occur from π^* orbital of the reductant to π^* orbital of oxidant. The reaction proceed by mechanism.
- The rate of electron transfer in $[\text{Co}(\text{NH}_3)_6]^{2+} / [\text{Co}(\text{NH}_3)_6]^{3+}$ system is than that of $[\text{Fe}(\text{CN})_6]^{4-} / [\text{Fe}(\text{CN})_6]^{3-}$ system.

- [Ans. 1. less 2. more
3. less 4. second
5. outer sphere 6. slower]

Objective Questions

- The final product containing chromium in the reaction between $[\text{Co}(\text{NH}_3)_5\text{Cl}]^{2+}$, $[\text{Cr}(\text{H}_2\text{O})_6]^{2+}$, H_3O^+ is :
(a) $[\text{Cr}(\text{NH}_3)(\text{H}_2\text{O})_4\text{Cl}]^{2+}$ (b) $[\text{Cr}(\text{H}_2\text{O})_6]^{3+}$
(c) $[\text{Cr}(\text{NH}_3)_5\text{Cl}]^{2+}$ (d) $[\text{Cr}(\text{H}_2\text{O})_5\text{Cl}]^{2+}$
- The chromium (III) species formed soon after electron transfer between IrCl_6^{2-} and $\text{Cr}(\text{H}_2\text{O})_6^{2+}$ is :
(a) $\text{Cr}(\text{H}_2\text{O})_6^{3+}$ (b) $\text{Cr}(\text{H}_2\text{O})_5\text{Cl}^{2+}$ *T₀ d³*
(c) CrCl_6^{3-} (d) $\text{Cr}(\text{H}_2\text{O})_3\text{Cl}_3$
- Electron transfer from $\text{Fe}(\text{H}_2\text{O})_6^{2+}$ to $\text{Fe}(\text{H}_2\text{O})_6^{3+}$ is likely to occur via :
(a) d-d transition (b) inner sphere electron transfer
(c) SN^1 (d) outer sphere electron transfer
- $[\text{CoCl}(\text{NH}_3)_5]^{3+} + [\text{Cr}(\text{H}_2\text{O})_6]^{2+} \rightarrow [\text{Co}(\text{H}_2\text{O})(\text{NH}_3)_5]^{2+} + [\text{CrCl}(\text{H}_2\text{O})_5]^{3+}$
The correct statements regarding the above reaction is that :
(a) It follows outer-sphere mechanism
(b) It follows inner-sphere mechanism with NH_3 acting as the bridging ligand
(c) It follows inner-sphere mechanism with Cl^- acting as the bridging ligand
(d) It is not an electron-transfer reaction
- The most suitable route to prepare the *trans*- isomer of $[\text{PtCl}_2(\text{NH}_3)(\text{PPh}_3)]$ is :

- $[\text{PtCl}_4]^{2-}$ with PPh_3 followed by reaction with NH_3 ✓
(b) $[\text{PtCl}_4]^{2-}$ with NH_3 followed by reaction with PPh_3 *PPh₃ Cl⁻ NH₃*
(c) $[\text{Pt}(\text{NH}_3)_4]^{2+}$ with HCl followed by reaction with PPh_3
(d) $[\text{Pt}(\text{NH}_3)_4]^{2+}$ with PPh_3 followed by reaction with HCl
- The rate of exchange of cyanide ligands in the complexes : (i) $[\text{Ni}(\text{CN})_4]^{2-}$, (ii) $[\text{Mn}(\text{CN})_6]^{3-}$ and (iii) $[\text{Cr}(\text{CN})_6]^{3-}$ by ^{14}CN follow the order : *d⁸ d⁴*
(a) ii > i > iii (b) iii > i > ii
(c) i > iii > ii (d) i > ii > iii *T₀ d⁸*
- Coordinated water molecules of a Cd(II) complexes can be successively replaced by Br^- finally result in $[\text{CdBr}_4]^{2-}$. In this process, the fourth equilibrium constant is observed to be higher than the third one, because :
(a) equilibrium constant for the last step is always the highest
(b) three molecules of H_2O are released during the fourth step
(c) the aqua-Cd(II) species is octahedral
(d) an anion (Br^-) replaces a neutral (H_2O) molecule from the coordination sphere
- The CORRECT statement regarding the thermodynamic stability and kinetic reactivity of metal ion complexes is that :
(a) More stable complexes are less reactive
(b) There exists a dependence on the bulkiness of the ligand
(c) There exists no direct relation between these two phenomenon *T₀ d⁸*
(d) There exists a dependence on the size of the metal ion
- The CORRECT order of the rate of exchange of water molecules between the coordination sphere and the bulk is :
(a) $\text{Cr}^{3+} < \text{Al}^{3+} < \text{Cr}^{2+} < \text{Ni}^{2+}$ (b) $\text{Cr}^{3+} < \text{Al}^{3+} < \text{Ni}^{2+} < \text{Cr}^{2+}$ *T₀ d³*
(c) $\text{Cr}^{3+} < \text{Ni}^{2+} < \text{Cr}^{2+} < \text{Al}^{3+}$ (d) $\text{Cr}^{3+} < \text{Cr}^{2+} < \text{Al}^{3+} < \text{Ni}^{2+}$ *Cr Ni T₀*
- Consider the reactions :
1. $[\text{Cr}(\text{H}_2\text{O})_6]^{2+} + [\text{CoCl}(\text{NH}_3)_5]^{2+} \rightarrow [\text{Co}(\text{NH}_3)_5(\text{H}_2\text{O})]^{2+} + [\text{CrCl}(\text{H}_2\text{O})_5]^{2+}$
2. $[\text{Fe}(\text{CN})_6]^{4-} + [\text{Mo}(\text{CN})_8]^{3-} \rightarrow [\text{Fe}(\text{CN})_6]^{3-} + [\text{Mo}(\text{CN})_8]^{4-}$
Which one of the following is the correct statement ?
(i) Both involve an inner sphere mechanism
(ii) Both involve an outer sphere mechanism
(iii) Reaction 1 follows inner sphere and reaction 2 follows outer sphere mechanism
(iv) Reaction 1 follows outer sphere and reaction 2 follows inner sphere mechanism.
(a) i (b) ii
(c) iv (d) iii
- Designate the following complexes X, Y and Z as inert or labile :
 $\text{X} = [\text{Al}(\text{C}_2\text{O}_4)_3]^{3-}$, $\text{Y} = [\text{V}(\text{H}_2\text{O})_6]^{2+}$, $\text{Z} = [\text{Cr}(\text{C}_2\text{O}_4)_3]^{3-}$ *T₀ d³*

- (a) X and Y are inert; Z is labile (b) X and Z are labile; Y is inert
 (c) X is inert; Y and Z are labile (d) X is labile; Y and Z are inert
12. Which one of the following electronic configuration gives kinetically inert octahedral complexes?
 (a) $t_{2g}^6 e_g^0$ (b) $t_{2g}^3 e_g^1$
 (c) $t_{2g}^5 e_g^0$ (d) $t_{2g}^6 e_g^4$
13. Reaction of $[\text{CoCl}(\text{NH}_3)_5]^{2+}$ by $\text{Cr}^{2+}(\text{aq})$ leads to the formation $[\text{CrCl}(\text{H}_2\text{O})_5]^{2+}$. This is an example of:
 (a) outer-sphere redox reaction (b) inner-sphere redox reaction
 (c) acid hydrolysis reaction (d) base hydrolysis reaction
14. The substitutionally inert complex ion amongst the following is:
 (a) $[\text{Cr}(\text{H}_2\text{O})_6]^{3+}$ (b) $[\text{Fe}(\text{H}_2\text{O})_6]^{2+}$
 (c) $[\text{Cr}(\text{H}_2\text{O})_6]^{2+}$ (d) $[\text{Ni}(\text{H}_2\text{O})_6]^{2+}$
15. The acid catalyzed hydrolysis of *trans*- $[\text{Co}(\text{en})_2\text{AX}]^{n+}$ can give *cis*-product due to the formation of:
 (a) square pyramidal intermediate
 (b) trigonal bipyramidal intermediate
 (c) pentagonal bipyramidal intermediate
 (d) face capped octahedral intermediate
16. Which one of the pairs of following statements about reduction of $[\text{CoCl}(\text{NH}_3)_5]^{2+}$ by $\text{Cr}(\text{II})$ is correct?
 (i) Reactant $[\text{CoCl}(\text{NH}_3)_5]^{2+}$ has non-labile coordination sphere
 (ii) Reaction proceeds by outer-sphere mechanism
 (iii) Reactant $[\text{CoCl}(\text{NH}_3)_5]^{2+}$ has labile coordination sphere
 (iv) Reaction proceeds by inner-sphere mechanism.
 (a) (i) and (ii) (b) (i) and (iii)
 (c) (ii) and (iii) (d) (iii) and (iv)
17. *cis*- and *trans*- complexes of the type $[\text{PtA}_2\text{X}_2]$ are distinguished by:
 (a) chromyl chloride test (b) carbylamine test
 (c) Kurnakov test (d) ring test
18. Consider two redox pairs:
 (1) $\text{Cr}(\text{II})/\text{Ru}(\text{III})$ (2) $\text{Cr}(\text{II})/\text{Co}(\text{III})$
 The rate of acceleration in going from a outer-sphere to an inner-sphere mechanism is lower for (1) relative to (2). Its correct explanation is:
 (a) HOMO/LUMO are σ^* and σ^* respectively.
 (b) HOMO/LUMO are σ^* and π^* respectively

- (c) HOMO/LUMO are π^* and σ^* respectively
 (d) HOMO/LUMO are π^* and π^* respectively
19. Consider the following pairs of complexes:
 $[\text{CoF}(\text{NH}_3)_5]^{2+}$ and $[\text{Cr}(\text{OH}_2)_6]^{2+}$; $[\text{Co}(\text{NH}_3)_5(\text{OH}_2)]^{3+}$ and $[\text{Cr}(\text{OH}_2)_6]^{2+}$
 $[\text{Co}(\text{NH}_3)_6]^{3+}$ and $[\text{Cr}(\text{OH}_2)_6]^{2+}$; $[\text{CoI}(\text{NH}_3)_5]^{2+}$ and $[\text{Cr}(\text{OH}_2)_6]^{2+}$
 The electron transfer rate will be fastest in the pair:
 (a) $[\text{CoF}(\text{NH}_3)_5]^{2+}$ and $[\text{Cr}(\text{OH}_2)_6]^{2+}$
 (b) $[\text{Co}(\text{NH}_3)_5(\text{OH}_2)]^{3+}$ and $[\text{Cr}(\text{OH}_2)_6]^{2+}$
 (c) $[\text{Co}(\text{NH}_3)_6]^{3+}$ and $[\text{Cr}(\text{OH}_2)_6]^{2+}$
 (d) $[\text{CoI}(\text{NH}_3)_5]^{2+}$ and $[\text{Cr}(\text{OH}_2)_6]^{2+}$
20. A true statement about base hydrolysis of $[\text{Co}(\text{NH}_3)_5\text{Cl}]^{2+}$ is:
 (a) It is a first order reaction
 (b) The rate determining step involves the dissociation of chloride in $[\text{Co}(\text{NH}_3)_4(\text{NH}_2)\text{Cl}]^+$
 (c) The rate is independent of the concentration of the base
 (d) The rate determining step involves the abstraction of a proton from $[\text{Co}(\text{NH}_3)_5\text{Cl}]^{2+}$
21. For the following outer sphere electron transfer reactions.
 $[\text{Co}(\text{NH}_3)_6]^{2+} + [\text{Co}^*(\text{NH}_3)_6]^{3+} \rightarrow [\text{Co}(\text{NH}_3)_6]^{3+} + [\text{Co}^*(\text{NH}_3)_6]^{2+}$
 $[\text{Ru}(\text{NH}_3)_6]^{2+} + [\text{Ru}^*(\text{NH}_3)_6]^{3+} \rightarrow [\text{Ru}(\text{NH}_3)_6]^{3+} + [\text{Ru}^*(\text{NH}_3)_6]^{2+}$
 The rate constants are $10^{-6} \text{ M}^{-1}\text{S}^{-1}$ and $8.2 \times 10^2 \text{ M}^{-1}\text{S}^{-1}$ respectively. This difference in the rate constants is due to:
 (a) a change from high spin to low spin in Co^* and high spin to low spin in Ru^*
 (b) a change from high spin to low spin in Co^* and low spin to high spin Ru^*
 (c) a change from low spin to high spin in Co^* and the low spin state remains unchanged in Ru^*
 (d) a change from low spin to high spin in Co^* and high spin to low spin in Ru^*
22. Which one of the following complexes is kinetically inert in a solution?
 (a) $[\text{Cr}(\text{H}_2\text{O})_6]^{2+}$ (b) $[\text{Cr}(\text{H}_2\text{O})_6]^{3+}$
 (c) $[\text{Co}(\text{H}_2\text{O})_6]^{2+}$ (d) $[\text{Ni}(\text{CN})_4]^{2-}$
23. The substitution reaction of $[\text{Co}(\text{CN})_5\text{Cl}]^{3-}$ with OH^- to give $[\text{Co}(\text{CN})_5\text{OH}]^{3-}$ in comparison to that $[\text{Co}(\text{NH}_3)_3\text{Cl}]^{2+}$ to give $[\text{Co}(\text{NH}_3)_5\text{OH}]^{2+}$ is:
 (a) slow and the rate depends only on $[\text{Co}(\text{CN})_5\text{Cl}]^{3-}$
 (b) fast and the rate depends only on $[\text{Co}(\text{CN})_5\text{Cl}]^{3-}$
 (c) slow and the rate depends on $[\text{Co}(\text{CN})_5\text{Cl}]^{3-}$ and OH^-
 (d) fast and the rate depends on $[\text{Co}(\text{CN})_5\text{Cl}]^{3-}$ and OH^-

24. Using crystal field theory, determine the type of d -orbital(s) which will have the lowest energy in the complex shown below. Based on the above, determine the comparative rates of reduction of the Mn(V) to Mn(IV) versus Mn(IV) to Mn(III) states :

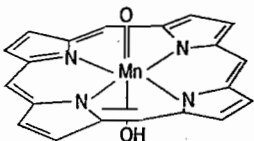

- (a) (d_{xy}); Mn(V) to Mn(IV) is slower than Mn(IV) to Mn(III)
 (b) (d_{xy} , d_{yz} , d_{zx}); Mn(V) to Mn(IV) is slower than Mn(IV) to Mn(III)
 (c) (d_{z^2} , $d_{x^2-y^2}$); Mn(V) to Mn(IV) is faster than Mn(IV) to Mn(III)
 (d) (d_{xy}); Mn(V) to Mn(IV) is faster than Mn(IV) to Mn(III)

25. Successive addition of NaCl, H_3PO_4 , KSCN and NaF to a solution of $Fe(NO_3)_3 \cdot 9H_2O$ gives yellow, colourless, red and again colorless solutions due to the respective formation of:

- (a) $[Fe(H_2O)_5Cl]^{2+}$, $[Fe(H_2O)_5(PO_4)]$, $[Fe(H_2O)_5(SCN)]^{2+}$, $[Fe(H_2O)_5F]^{2+}$
 (b) $[Fe(H_2O)_5Cl(OH)]^+$, $[Fe(H_2O)_5(PO_4)]$, $[Fe(H_2O)_5(SCN)]^{2-}$, $[Fe(H_2O)_5F]^{2+}$
 (c) $[Fe(H_2O)_5Cl]^{2+}$, $[Fe(H_2O)_6]^{3+}$, $[Fe(H_2O)_5(SCN)]^{2+}$, $[Fe(H_2O)_5F]^{2+}$
 (d) $[Fe(H_2O)_5Cl]^{2+}$, $[Fe(H_2O)_5(PO_4)]$, $[Fe(H_2O)_5(SCN)]^{2+}$, $[Fe(H_2O)_4(SCN)F]^+$

26. The rate of exchange of OH_2 present in the coordination sphere by $^{18}OH_2$ of, (i) $[Cu(OH_2)_6]^{2+}$, (ii) $[Mn(OH_2)_6]^{2+}$, (iii) $[Fe(OH_2)_6]^{2+}$, (iv) $[Ni(OH_2)_6]^{2+}$, follows an order:

- (a) (i) > (ii) > (iii) > (iv) (b) (i) > (iv) > (iii) > (ii)
 (c) (ii) > (iii) > (iv) > (i) (d) (iii) > (i) > (iv) > (ii)

ANSWERS

- | | | | | | | |
|---------|---------|---------|---------|---------|---------|---------|
| 1. (d) | 2. (a) | 3. (d) | 4. (c) | 5. (a) | 6. (d) | 7. (b) |
| 8. (c) | 9. (b) | 10. (c) | 11. (d) | 12. (a) | 13. (b) | 14. (a) |
| 15. (b) | 16. (d) | 17. (c) | 18. (b) | 19. (d) | 20. (b) | 21. (c) |
| 22. (d) | 23. (a) | 24. (a) | 25. (a) | 26. (a) | | |

Subjective Questions

- Explain the term thermodynamic and kinetic stability. Are these two terms inter related? Explain giving examples.
- Explain the term lability and inertness giving examples on the basis of CFT.

3. Arrange the following complexes in the increasing order of inertness :

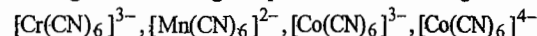

4. What is *trans*-effect? What product is obtained when $[PtCl_4]^{2-}$ is treated with :

(i) NH_3 followed by R_3P ,

(ii) R_3P followed by NH_3 ?

5. Square planar complexes are generally labile. Explain.

6. For the following general reaction,

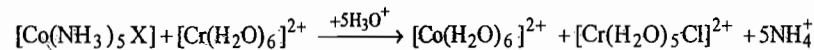

rate constant increases in the order $X^- = F^-, Cl^-, Br^-, I^-$. Explain. Also give the mechanism of the above reaction.

7. Give the mechanism of the following reaction :

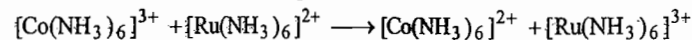

Also explain why this reaction is rather slow ($k = 1 \times 10^{-2} \text{ m}^{-1} \text{ s}^{-1}$)?

8. Give the mechanism of the following reaction and speculate why the electron transfer is slow ($k = 1 \times 10^{-2} \text{ m}^{-1} \text{ s}^{-1}$)?

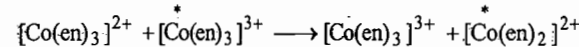

9. Suggest the mechanism of the following reaction :

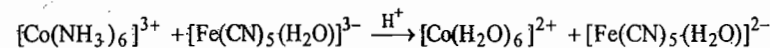

10. For each of the following electron-transfer reaction, speculate whether the mechanism is inner sphere or outer sphere :

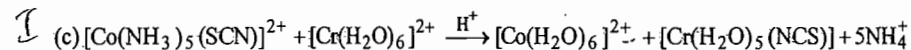
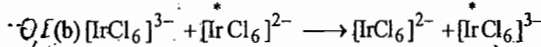
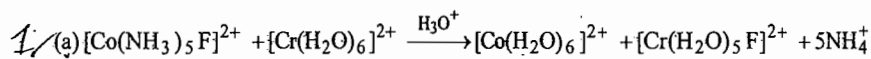

11. Give the mechanism of electron transfer reaction between $[Co(NH_3)_5(SCN)]^{2+}$ and $[Cr(H_2O)_6]^{2+}$. Considering : (i) remote attack and (ii) adjacent attack.

12. The second order rate constants for the reactions :

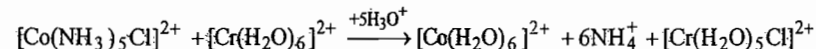
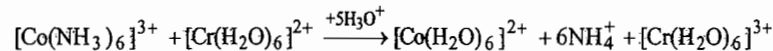

are $10^{-3} \text{ m}^{-1} \text{ s}^{-1}$ and $6 \times 10^5 \text{ m}^{-1} \text{ s}^{-1}$ respectively. Explain the variation in rate constants by giving the mechanism.

13. Anhydrous CrCl_3 dissolves more rapidly in a dilute solution of CrCl_2 than in pure water. Explain.
14. The formation of Cu^{2+} complexes with ethylenediamine exhibit the equilibrium constants $\log K_1 = 10.50$, $\log K_2 = 9.0$ and $\log K_3 = -1.0$. Explain the lower value of K_3 than K_2 .
15. The successive stability constants for the species formed in aqueous solutions when ethylenediamine reacts with Ni(II) are as follows :

$$\log K_1 = 7.5, \log K_2 = 6.4 \text{ and } \log K_3 = 4.4.$$

Calculate value of β_3 .

16. When the pyridine is added to an aqueous solution of Na_3RhCl_6 , the reaction stops at $[\text{Rh}(\text{py})_3\text{Cl}_3]$ but on adding a small amount of ethanol, quantitative formation of $[\text{Rh}(\text{py})_4\text{Cl}_2]^+$ occurs. Explain this by giving suitable mechanism.
17. Explain the importance of bridging group in inner sphere mechanism. Explain the following data when bridging group X is changed as follows in the reaction of $[\text{Co}(\text{NH}_3)_5\text{X}]^{2+}$ with $\text{Cr}_{(\text{aq})}^{2+}$.

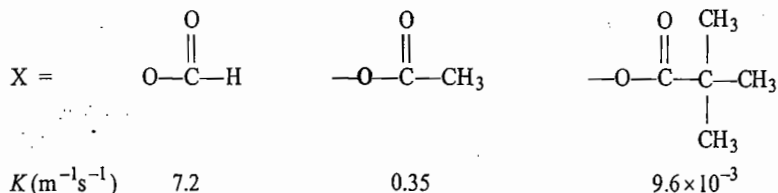

18. Explain the rate enhancement for the following reaction pairs :

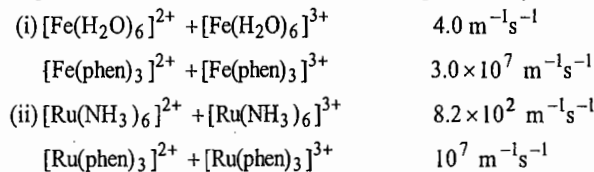

□□□

References

1. Coordination compounds, Bonding, Structure and Nomenclature, Ramanee D. Wijesekera.
2. Chemistry of the elements, N.N. Green Wood and A. Earnshaw, Second edition.
3. Advanced Inorganic Chemistry, F. Albert Cotton, Geoffrey A. Murillo, Manfred Bochmann, Sixth edition.
4. Inorganic chemistry, Gary Wulfsberg.
5. Inorganic chemistry, A.G. Sharpe, Third edition.
6. Chemistry, Mc Murry and Fay, Second edition.
7. Chemistry, Raymond Chang, Eight edition, Tata McGraw-Hill.
8. Concise Inorganic Chemistry, J.D.Lee, Fifth edition.
9. Descriptive Inorganic Chemistry, Geoff Rayner-Canham, Tina Overton, Fifth edition.
10. Physical Chemistry, Peter Atkins, Julio De Paula, 8th edition.
11. Inorganic chemistry, Principles of Structures and Reactivity, James E. Huheey, Ellen A. Keiter, Richard L. Keiter, Okhil K. Medhi.
12. Inorganic and Solid-state Chemistry, Glen E. Rodger.
13. Physical Methods in Inorganic Chemistry, Russell S. Drago, 1965.
14. Basic Inorganic Chemistry, F.A. Cotton, G. Wilkinson, Paul L. Gaur, Third Edition 2003.
15. Modern Inorganic Chemistry, William L. Jolly, Second edition.
16. Fundamentals of Molecular Spectroscopy, Colin N. Banwell, Elaine M. McCash, Fourth edition.
17. Inorganic Chemistry, Catherine E. Housecraft and A.G. Sharpe, Second edition.

18. Inorganic Chemistry, D.F. Shriver, P.W. Atkins, Third edition.
19. Concept and Models of Inorganic Chemistry, Bodie E. Douglas, D.H. McDaniel, John J. Alexander, John Wiley and Sons.
20. An Introduction to Inorganic Chemistry, Keith F. Purcell, John C. Kotz, 1980.
21. Mechanism of Inorganic Reaction, A study of metal complexes in solutions, Fred Basolo and Ralph G. Pearson, 1973.

Index

A

- Ambidentate Ligands (1.16)
- Angular Momentum of an Electron (5.4)
- Application of CFSE
 - ❖ Enthalpy of Hydration of Transition Metal Ions (4.33)
 - ❖ Lattice Energy (4.34)
 - ❖ Ionic Radii of Divalent Metal of 3d-series Transition Elements (4.35)
 - ❖ Structures of Spinels (4.37)
 - Normal Spinels (4.37)
 - Inverse Spinels (4.37)
- Acid Hydrolysis (7.21)
- Anation Reactions (7.20)
- Antiferromagnetic Substances (6.5)
- Aquation Reaction (7.21)
- Artist's Colour Wheel (5.1)

B

- Bridging Ligand (1.17)
- Base Hydrolysis (7.23)
- Beer-Lambert Law (5.4)

C

- Classification of Ligands (1.10)
 - ❖ Monodentate Ligands (1.11)
 - ❖ Polydentate Ligands (1.12)
- Classification of Polydentate Ligands (1.12)
 - ❖ Bidentate Ligands (1.12)
 - ❖ Tridentate Ligands (1.14)
 - ❖ Tetradentate Ligands (1.15)
 - ❖ Pentadentate Ligands (1.15)
 - ❖ Hexadentate Ligands (1.16)
- Charge Transfer spectra
 - ❖ LMCT (5.43)
 - ❖ MLCT (5.45)
 - ❖ Intervalence Transition (5.46)

D

- Diamagnetic Substances (6.5)
- Dynamic Jahn-Teller Distortion (4.30)

E

- Evidence for Dissociation (S_{N1}) Mechanism (7.19)
- Evidence in Favour of Associative Mechanism (7.45)
- Evidence for Metal Ligand Covalent Bonding in Complexes (4.40)
 - ❖ Electron Spin Resonance (ESR) (4.40)
 - ❖ Nuclear Magnetic Resonance (NMR) (4.40)
 - ❖ Nephelauxetic Effect (4.40)
 - ❖ Nuclear Quadropole (NQR) (4.40)
- Evidence in Favour of Werner's Theory (1.7)
- Electron Spin Angular Momentum (5.5)
 - ❖ Intra Ligand Charge Transfer (5.47)
- Complementary and Non-complementary Reactions (7.68)
- Class 'a' and 'b' metals (7.7)
- Crystal Field Splitting in
 - ❖ Octahedral Complexes (4.15)
 - ❖ Tetrahedral Complexes (4.17)
 - ❖ Square Planar Complexes (4.31)
- Crystal Field Splitting Diagram for
 - ❖ Trigonal bipyramidal Complexes (4.52)
 - ❖ Square pyramidal Complexes (4.52)
 - ❖ Pentagonal bipyramidal Complexes (4.52)
- Crystal field stabilization energy in
 - ❖ Octahedral Complexes (4.22)
 - ❖ Tetrahedral Complexes (4.25)
- Crystal Field Theory (4.13)
- Curie Law (6.4)
- Curie-Weiss Law (6.4)

F

- Flexidentate Ligands (1.17)
- Factors Affecting Stability of Complexes
 - ✦ Nature of the Central Metal Ion (7.5)
 - ✦ Nature of the Ligands (7.8)
 - ✦ The Chelate Effect (7.8)
 - ✦ Macrocyclic Effect (7.11)
 - ✦ Resonance Effect (7.11)
 - ✦ Steric Effect or Steric Hindrance (7.11)
- Facial and Meridional Isomers (2.19)
- Ferrimagnetic Substances (6.5)
- Ferromagnetic Substances (6.5)

G

- Geometrical isomerism (2.14)
 - ✦ Octahedral Complexes (2.17)
 - ✦ Square Planar Complexes (2.15)

H

- Homoleptic and Heteroleptic Complexes (1.20)
- High Spin Complexes (4.21)
- High spin-low spin Equilibria (6.11)
- Hydrate Isomerism (2.10)

I

- Isomerism (2.9)
 - ✦ Structural Isomerism (2.9)
 - ✦ Stereoisomerism (2.14)
- Inner Sphere Mechanism (7.55)
- Irving William Series (7.6)
- Interpretation of Lability and Inertness of Transition Metal Complexes (7.16)
- IUPAC Nomenclature (3.1)
- Inverse spinels (4.37)

J

- Jahn-Teller Distortion (4.25)
 - ✦ Static and Dynamic (4.30)

K

- Kinetic Stability : Lability and Inertness (7.12)
- Kurnakov Test (7.39)

L

- Ligands (1.1)
 - ✦ Ambidentate (1.16)
 - ✦ Bridging (1.17)
 - ✦ Flexidentate (1.17)
 - ✦ Macrocyclic (1.20)
- Ligand Field Theory (4.41)
- Ligand Isomerism (2.12)
- Linkage Isomerism (2.10)
- Low Spin Complexes (4.21)

M

- Macrocyclic Ligands (1.20)
- Mechanism of Substitution Reactions in Square Planar Complexes (7.42)
- Magnetic Moment (6.6)
- Magnetic Susceptibility (6.2, 6.6)
- Magnetism (6.1)
- Microstates (5.8)
- Marcus-Hush Relationship (7.54)

N

- Naming of Bridged Polynuclear Complexes (3.5)
- Naming of Coordination Compounds having Cation and Anion both as Complex Ions (3.8)
- Naming of Complexes containing Hydrated Water Molecule (3.14)
- Naming of Geometrical Isomers (3.14)
- Naming of Optical Isomers (3.15)
- Normal Spinel (4.37)

O

- Optical or Mirror Image Isomerism (2.28)
- Optical Isomerisms in Square Planar Complexes (2.28)

- Orbital Angular Momentum (5.4)
- Orbital Contribution (6.9)
- Outer Sphere Mechanism (7.46)

P

- Pairing Energy (4.22)
- Paramagnetic Substances (6.5)
- π -acceptors (4.48)
- π -bonding in Octahedral Complexes (4.46)
- π -donors (4.47)
- Polymerization Isomerism (2.13)
- Precipitation Reactions (1.18)
- Photochemical Reactions (7.72)

R

- Racah Parameters and Nephelauxetic Series (5.42)
- Reaction Profiles for Dissociative, Associative and Interchange Mechanisms (7.15)
- Redox Reactions or Electron Transfer Reactions (7.46)
- Remote Attack (7.59)

S

- Symmetrical and Unsymmetrical Bidentate Ligands (1.18)
- Selection Rules
 - ✦ Laporte's Selection (5.13)
 - ✦ Spin Selection (5.14)
- Spectrochemical Series (4.20)
- Spectroscopic Terms (5.9)
- Substitution Reactions in Octahedral Complexes (7.13)
- Substitution Reaction in Square Planar Complexes (7.32)
- Stereochemistry of Acid Catalyzed Substitution Reactions (7.29)

- Sidwick Concept of Coordinate Bond (1.8)
- Sigma Bonding in :
 - ✦ Tetrahedral Complexes (4.49)
 - ✦ Square Planar Complexes (4.50)
- Substitution Reactions without breaking Metal-Ligand Bond (7.28)
- Spin-Orbital Coupling (5.7)
 - ✦ L-S Coupling or Russel-Saunders Coupling (5.7)
 - ✦ J-J Coupling (5.8)

T

- Tetragonal Distortion (4.25)
- Tanabe-Sugano Diagrams (5.47)
- Term Symbols (5.9)
- Thermodynamic Stability (7.1)
- Total Angular Momentum of Many Electron Atoms (5.6)
 - ✦ Total Orbital Angular Momentum (5.6)
 - ✦ Total Spin Angular Momentum (5.7)
 - ✦ Spin Orbit Coupling (5.7)
- Trans Effect (7.35)
- Theories of Trans Effect
 - ✦ Polarization theory (7.39)
 - ✦ π -bonding theory (7.41)
- Two Electron Transfer (7.67)
- Total Angular Momentum (5.6)

V

- Valence Bond Theory (4.1)

W

- Werner's Theory (1.2)
- Water Exchange (7.19)